

**MOUNT AIRY LODGE REDEVELOPMENT  
TRAFFIC IMPACT STUDY**

*For Submission To*  
**PARADISE TOWNSHIP  
MONROE COUNTY, PENNSYLVANIA**

**TPD # CECO.A.00008**

**August 16, 2005**

**Prepared by:  
Traffic Planning and Design, Inc.  
Sanatoga Commons  
2500 East High Street, Suite 650  
Pottstown, Pennsylvania 19464**

**Phone: (610) 326-3100  
Fax: (610) 326-9410  
E-mail: [TrafficExperts@TrafficPD.com](mailto:TrafficExperts@TrafficPD.com)  
Web Site: [www.trafficpd.com](http://www.trafficpd.com)**

**Respectfully submitted,  
TRAFFIC PLANNING AND DESIGN, INC.**

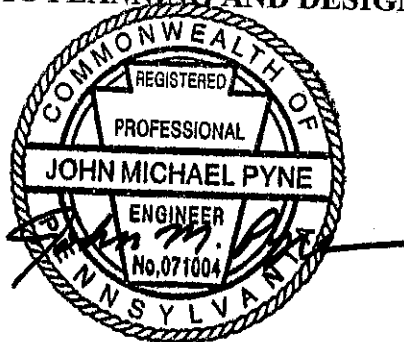

**John M. Pyne, P.E.  
Associate  
Pennsylvania P.E. No. 071004**

# Table of Contents

	<u>Page</u>
EXECUTIVE SUMMARY.....	i
LOS MATRICES .....	iv
INTRODUCTION.....	1
EXISTING ROAD NETWORK.....	1
SITE ACCESS.....	2
SIGHT DISTANCE ANALYSIS .....	2
PLANNED ROADWAY IMPROVEMENTS.....	4
EXISTING TRAFFIC VOLUMES .....	5
BASE CONDITIONS .....	7
TRIP GENERATION.....	10
TRIP DISTRIBUTION .....	11
PROJECTED CONDITION TRAFFIC VOLUMES.....	12
LEVELS OF SERVICE (LOS) FOR AN INTERSECTION.....	12
CAPACITY ANALYSIS METHODOLOGY .....	13
LEVELS OF SERVICE IN THE STUDY AREA .....	14
SIGNAL WARRANT ANALYSIS.....	21
AUXILIARY LANE ANALYSIS.....	23
QUEUE LENGTH ANALYSIS .....	24
RECOMMENDATIONS .....	25
CONCLUSIONS .....	26

## Figures 1-27

### Technical Appendices

- Appendix A: Study Area Photographs**
- Appendix B: Manual Traffic Count Printouts & ITMS Data Sheets**
- Appendix C: Trip Distributions: Nearby Planned Developments**
- Appendix D: Dover Downs Manual Traffic Count Printouts**
- Appendix E: 200-Mile Radius Gravity Model**
- Appendix F: Capacity Analysis Worksheets**
- Appendix G: Route 611/Route 314 (Western Leg) Signalization Info**
- Appendix H: Signal Warrant Analysis Worksheets**
- Appendix I: Auxiliary Lane Analysis Worksheets**
- Appendix J: 95<sup>th</sup> Percentile Queue Length Summary**
- Appendix K: Signal Diagrams**

## EXECUTIVE SUMMARY

The purpose of this study is to examine the potential traffic impact of the proposed Mount Airy Lodge redevelopment on the surrounding transportation system in Paradise Township, Monroe County, Pennsylvania. Upon completion of the traffic impact study the following has been determined:

- The site for the proposed development is located on the southern side of Woodland Road, between Carlton Road and Bowman Road. The proposed redevelopment will consist of a 3,000 machine slot parlor including food and beverage support services, and a 200-room hotel.
- Access to the proposed development will be provided by two (2) full-access site driveways to Woodland Road. The full-access site driveways will be located approximately 1,400 feet and 2,700 feet east of the centerline of Meadowside Road, respectively. The site driveways will be designed as high-volume driveways with two entering lanes and two exiting lanes, with proper channelization. In addition, left and right-turn lanes will be provided on the Woodland Road approaches to the site driveways.
- The proposed development will generate 1,020 new vehicle-trips during the Friday P.M. peak hour (approximately 17 new vehicle-trips every minute) and 1,140 new vehicle-trips during the Saturday P.M. peak hour (approximately 19 new vehicle-trips every minute).
- Future condition traffic volumes were calculated to include existing traffic, traffic due to thirteen (13) nearby planned developments, future “background” traffic growth, and all traffic due to the redevelopment of the Mount Airy Lodge facility.
- Analyses were conducted to determine the quality of operation (i.e. level of service) at the study area intersections for Existing, 2007 Base, 2017 Base, 2007 Projected, and 2017 Projected Conditions. Additional analyses were conducted at the site driveway intersections for 2007 and 2017 Projected Conditions.
- The following roadway improvements are proposed by others at the study area intersections regardless of redevelopment of the Mount Airy Lodge:
  - Route 611 will be resurfaced from Fairview Avenue in Mount Pocono Borough to Woodland Road in Paradise Township. In conjunction with the resurfacing, left-turn lanes will be constructed along Route 611 at the intersections of Grange Road, Meadowside Road/Trinity Hill Road and Wiscasset Road.
  - A traffic signal will be installed at the intersection of Route 940 and Carlton Road/Caesar’s Resort Driveway.
  - A traffic signal will be installed at the intersection of Route 940 and Route 390. As part of the signalization of the intersection, the southbound Route 390 approach to the intersection will be reconfigured to form a “T” intersection, thus eliminating the bifurcation

- As a result of the traffic impact study, the following site-related recommendations have been offered:

### **Woodland Road**

Widen Woodland Road from Route 611 to Carlton Road (approximately 2 miles) as follows:

- Widen Woodland Road from a two-lane (20-22 foot wide roadway) to a three-lane, 40-foot wide curbed roadway from Route 611 to 500 feet east of the proposed eastern Mount Airy Lodge site drive. The third lane will be striped as a center left turn lane resulting in left turn lanes on Woodland Road at its intersections with the Pocono Mountain School District Driveway, Bowman Road, Meadowside Road, and two Mount Airy Lodge site driveways.
- Widen Woodland Road to provide 250-foot long right turn deceleration lanes with 100-foot long tapers on Woodland Road at its intersections with the Pocono Mountain School District Driveway, Bowman Road, Meadowside Road, and two Mount Airy Lodge site driveways.
- Widen Woodland Road from 225 feet east of the proposed eastern Mount Airy Lodge site drive to Carlton Road to provide 11-foot wide travel lanes and 5-foot shoulders. This section of Woodland Road will remain two lanes wide.
- Horizontal and vertical geometric and alignment improvements along sections of Woodland Road including realignment in some sections, and superelevation.
- It is recommended that the speed limit for Woodland Road be reduced from 40 mph to 35 mph from Route 611 to 225 feet east of the proposed eastern Mount Airy Lodge site drive as a result of the horizontal geometry and curbing proposed for the roadway. It is further recommended that advisory 25 mph speed limit signs be placed for the three horizontal curves between Bowman Road and Meadowside Road.

### **Route 611 and Woodland Road/ Strickland's Road/Big Daddy's Driveway**

- Construct a separate 250-foot long left-turn lane, with a 100-foot long taper on the westbound Woodland Road approach to Route 611.
- Construct a 250-foot long right-turn lane, with a 100-foot long taper on the westbound Woodland Road approach to Route 611.
- Re-designate the existing westbound Woodland Road approach to Route 611 in order to provide a shared left/through travel lane.
- Construct a separate 350-foot long right-turn lane, with a 210-foot long taper on the northbound Route 611 approach to Woodland Road.
- Close the Strickland's Road approach to the Route 611/Woodland Road/Big Daddy's intersection, thus eliminating the 5-leg intersection.
- Install new traffic signal equipment (controller, mast arms, signal heads) at the intersection of Route 611 and Woodland Road/Big Daddy's Driveway in order to accommodate the proposed traffic signal phasing.

### **Route 940 and Carlton Road**

- Construct a separate 100-foot long left-turn lane, with a 100-foot long taper on the westbound Route 940 approach to Carlton Road.

**Route 611 and Route 314 (Eastern Leg)**

- Increase the cycle length of the traffic signal from 80 seconds to 100 seconds during the weekday P.M. peak hour. It will be at the discretion of Pocono Township and PennDOT whether or not the cycle length of the traffic signal at the intersection should be modified.

**Route 611 and Route 314 (Western Leg)**

- Discuss/investigate the potential installation of a traffic signal at the intersection of Route 611 and Route 314 (Western Leg) with Pocono Township and PennDOT to determine if installing the traffic signal is feasible.
- The improvements outlined above should be implemented to improve future level of service deficiencies, offset level of service impacts, and to provide safe and efficient access to the proposed development.
- Level of service matrices for the study area intersections are shown in Tables I and II on the following pages for the Friday P.M. and Saturday P.M. peak hours.

**TABLE I  
LEVEL OF SERVICE SUMMARY  
FRIDAY P.M. PEAK HOUR**

Intersection	Approach/ Movement		2005	2007	2007	2017	2017
			Existing	Base	Projected*	Base	Projected*
Route 611 & Route 314 (Eastern Leg)	WB	L	C	C	D	C	D
	WB	R	B	B	C	B	C
	NB	T/R	C	F (94.8)	F (88.9)	F (241.1)	F (233.5)
	SB	L	B	B	C	C	C
	SB	T	A	A	A	B	B
	<b>ILOS</b>		<b>B</b>	<b>D</b>	<b>D</b>	<b>F (122.5)</b>	<b>F (124.3)</b>
Route 611 & Route 314 (Western Leg)	EB	L	F	F	F	F	F
	EB	R	C	D	E	F	F
	NB	L	B	C	F	F	F
Route 611 & Woodland Road/ Strickland's Road/ Big Daddy's Driveway	EB	L/T/R	C	C	C	C	C
	WB	L	C	C	C	C	C
	WB	L/T			C		C
	WB	R			B		B
	NB	L	A	B	B	B	B
	NB	T	B	B	B	C	C
	NB	R			A		A
	SB	L	A	B	B	B	B
	SB	T/R	A	A	A	B	A
	SWB	L/T/R	C	D	---	D	---
	<b>ILOS</b>		<b>B</b>	<b>B</b>	<b>B</b>	<b>C</b>	<b>B</b>
Route 611 & Meadowside Road/ Trinity Hill Road	EB	L/T/R	B	B	B	B	B
	WB	L/T/R	C	D	D	E	E
	NB	L	A	B	B	B	B
	SB	L	A	B	B	B	B
Route 611 & Grange Road/ Green Springs Driveway	EB	L/T/R	-	F	F	F	F
	WB	L/T/R	C	F	F	F	F
	NB	L	-	B	B	B	B
	SB	L	A	B	B	B	B

\* = With Site-Related Recommendations

**TABLE I - CONTINUED**

Intersection	Approach/ Movement		2005	2007	2007	2017	2017
			Existing	Base	Projected*	Base	Projected*
Woodland Road & Pocono Mountain School Road	WB	L	A	A	A	A	A
	NB	L/R	B	B	C	B	C
Woodland Road & Bowman Road	WB	L	A	A	A	A	A
	NB	L/R	A	B	C	B	C
Woodland Road & Meadowside Road	EB	L	A	A	A	A	A
	SB	L/R	A	A	C	A	C
Woodland Road & Carlton Road	EB	L/T	B	B	B	B	C
	NB	L	A	A	A	A	A
Route 940 & Carlton Road/ Caesar's Resort Driveway	EB	L	A	B	B	B	C
	EB	T/R	---				
	WB	L	A	A	A	B	A
	WB	T/R			A		A
	NB	L/T/R	D	C	B	C	C
	SB	L/T/R	D	C	B	C	C
	<b>ILOS</b>		---	<b>B</b>	<b>B</b>	<b>C</b>	<b>B</b>
Route 940 & Route 390	EB	L	A	B	B	C	D
	EB	T	---				
	WB	T/R	---	B	B	B	B
	SB	L	B	D	D	D	D
	SB	R	B				
	<b>ILOS</b>		---	<b>C</b>	<b>C</b>	<b>C</b>	<b>D</b>
Route 940 & Route 191/ Red Rock Road	EB	L/T/R	A	A	A	A	A
	WB	L/T/R	A	A	A	A	A
	NB	L/T/R	B	C	C	C	C
	SB	L/T/R	C	C	C	E	E
Woodland Road & Eastern Site Driveway	WB	L	---	---	A	---	A
	NB	L	---	---	C	---	C
	NB	R	---	---	A	---	A
Woodland Road & Western Site Driveway	WB	L	---	---	A	---	A
	NB	L	---	---	D	---	D
	NB	R	---	---	B	---	B

\* = With Site-Related Recommendations

**TABLE II  
LEVEL OF SERVICE SUMMARY  
SATURDAY P.M. PEAK HOUR**

Intersection	Approach/ Movement		2005	2007	2007	2017	2017
			Existing	Base	Projected*	Base	Projected*
Route 611 & Route 314 (Eastern Leg)	WB	L	C	C	D	C	D
	WB	R	C	C	C	C	C
	NB	T/R	A	B	B	C	C
	SB	L	A	A	B	B	C
	SB	T	A	A	A	A	A
	<b>ILOS</b>		<b>A</b>	<b>B</b>	<b>B</b>	<b>B</b>	<b>B</b>
Route 611 & Route 314 (Western Leg)	EB	L	D	F	F	F	F
	EB	R	B	B	C	C	C
	NB	L	A	B	C	B	C
Route 611 & Woodland Road/ Strickland's Road/ Big Daddy's Driveway	EB	L/T/R	C	C	C	C	C
	WB	L	D	C	C	C	C
	WB	L/T			C		C
	WB	R			B		B
	NB	L	A	A	B	A	B
	NB	T	A	B	C	B	C
	NB	R			A		A
	SB	L	A	A	B	A	B
	SB	T/R	A	A	A	A	A
	SWB	L/T/R	D	D	---	D	---
	<b>ILOS</b>		<b>A</b>	<b>A</b>	<b>B</b>	<b>B</b>	<b>B</b>
Route 611 & Meadowside Road/ Trinity Hill Road	EB	L/T/R	B	D	F	F	F
	WB	L/T/R	C	F	F	F	F
	NB	L	A	B	B	B	B
	SB	L	A	B	B	B	B
Route 611 & Grange Road/ Green Springs Driveway	EB	L/T/R	-	F	F	F	F
	WB	L/T/R	C	F	F	F	F
	NB	L	-	B	B	B	B
	SB	L	A	B	B	B	B

\* = With Site-Related Recommendations



**TABLE II - CONTINUED**

Intersection	Approach/ Movement		2005	2007	2007	2017	2017
			Existing	Base	Projected*	Base	Projected*
Woodland Road & Pocono Mountain School Road	WB	L	A	A	A	A	A
	NB	L/R	A	A	B	A	C
Woodland Road & Bowman Road	WB	L	A	A	A	A	A
	NB	L/R	A	A	C	A	C
Woodland Road & Meadowside Road	EB	L	A	A	A	A	A
	SB	L/R	A	A	C	A	C
Woodland Road & Carlton Road	EB	L/T	B	B	B	B	B
	NB	L	A	A	A	A	A
Route 940 & Carlton Road/ Caesar's Resort Driveway	EB	L	A	B	B	B	B
	EB	T/R	---				
	WB	L	A	A	A	B	A
	WB	T/R			A		A
	NB	L/T/R	C	C	B	C	B
	SB	L/T/R	B	B	B	C	B
	<b>ILOS</b>		---	<b>B</b>	<b>B</b>	<b>B</b>	<b>B</b>
Route 940 & Route 390	EB	L	A	B	B	C	C
	EB	T	---				
	WB	T/R	---	B	B	B	B
	SB	L	B	C	C	D	D
	SB	R					
	<b>ILOS</b>		---	<b>B</b>	<b>B</b>	<b>C</b>	<b>C</b>
Route 940 & Route 191/ Red Rock Road	EB	L	A	A	A	A	A
	WB	L	A	A	A	A	A
	NB	L/T/R	B	C	C	C	C
	SB	L/T/R	B	C	C	E	E
Woodland Road & Eastern Site Driveway	WB	L	---	---	A	---	A
	NB	L	---	---	C	---	C
	NB	R	---	---	A	---	A
Woodland Road & Western Site Driveway	WB	L	---	---	A	---	A
	NB	L	---	---	C	---	D
	NB	R	---	---	A	---	A

\* = With Site-Related Recommendations

**INTRODUCTION**

Traffic Planning and Design, Inc. (TPD) has completed a traffic impact study (TIS) for the proposed Mount Airy Lodge redevelopment in Paradise Township, Monroe County, Pennsylvania. As shown in Figure 1, the site for the proposed development is located on the southern side of Woodland Road, between Carlton Road and Bowman Road. The proposed redevelopment will consist of a 3,000 machine slot parlor including food and beverage support services, and a 200-room hotel (see Figure 2).

**EXISTING ROAD NETWORK**

A survey of the existing roadway system in the study area is provided below in Table 1. The existing lane configurations and intersection controls are depicted in Figure 3. Photographs of the study area intersections are included in Appendix A.

**TABLE 1  
EXISTING ROADWAY CHARACTERISTICS**

<b>Roadway</b>	<b>Roadway Jurisdiction</b>	<b>Posted Speed Limit</b>	<b>Travel Lane Width</b>	<b>Shoulder Width</b>
Route 611	State (S.R. 0611)	45 m.p.h.	11-12'	0-10'
Route 314 (East)	State (S.R. 0314)	35 m.p.h.	12-13'	0'
Route 314 (West)	State (S.R. 0314)	40 m.p.h.	10'	4'
Woodland Road	State (S.R. 1013)	40 m.p.h.	10-13'	0-2'
Strickland's Road	Township (T-612)	35 m.p.h.	11'	0'
Big Daddy's Drive	Private	Not Posted	15'	0'
Meadowside Road	Township (T-610)	35 m.p.h.	10-12'	0'
Trinity Hill Road	Township (T-563)	35 m.p.h.	13'	0'
Grange Road	Township/Borough (T-559)	35 m.p.h.	10'	0'
Route 940	State (S.R. 0940)	45 m.p.h.	11'	2-10'
Carlton Road	State (S.R. 1011)	45 m.p.h.	11'	0-4'
Caesar's Resort Drive	Private	15 m.p.h.	11'	0'
Route 390	State (S.R. 0390)	45 m.p.h.	11'	0-4'
Route 191	State (S.R. 0191)	45 m.p.h.	11'	0'
Red Rock Road	Township (T-635)	35 m.p.h.	8'	0'
School Access	Township (T-616)	25 m.p.h.	11'	3'
Bowman Road	Township (T-563)	35 m.p.h.	11'	0'

## SITE ACCESS

Access to the proposed development will be provided by two (2) full-access site driveways to Woodland Road. The full-access site driveways will be located approximately 1,400 feet and 2,700 feet east of the centerline of Meadowside Road, respectively.

The site driveways will be designed as high-volume driveways with two entering lanes and two exiting lanes, with proper channelization. In addition, left and right-turn lanes will be provided on the Woodland Road approaches to the site driveways.

## SIGHT DISTANCE ANALYSIS

A sight distance analysis was performed for the proposed site driveways. In general, recommended safe sight distances depend upon the posted speed limit, roadway grades, and the number of travel lanes. The proposed sight distances at the site driveways were measured and compared to the desirable sight distance standards as specified in Title 67 of the PA Code, Chapter 441, "Access to and Occupancy of Highways by Driveways and Local Roads," August, 1996. The proposed sight distances were also compared to PennDOT's safe stopping sight distance (SSSD) standard as calculated by the following equation:

$$SSSD = 1.47VT + V^2/[30(f \pm g)]$$

SSSD = safe stopping sight distance (acceptable sight distance)

V = 85th Percentile Speed

T = Perception Reaction Time of Driver (2.5 seconds)

f = Coefficient of Friction for Wet Pavements (average of 0.30)

g = Percent of Roadway Grade Divided by 100

PennDOT's desirable and safe stopping sight distance standards both exceed the stopping sight distance requirements as specified in A Policy on Geometric Design of Highways and Streets, of the American Association of State Highway and Transportation Officials (AASHTO), Chapter III, "Elements of Design," 2001.

### Eastern Full-Access Site Driveway

Table 2 shows the proposed, desirable, and safe stopping sight distances at the eastern site driveway for vehicles entering and exiting the site.

**TABLE 2**  
**SIGHT DISTANCE ANALYSIS**  
**PROPOSED EASTERN SITE DRIVEWAY**

	<i>Direction</i>	Design Speed (mph)	Grade <sup>1</sup> (%)	<i>Sight Distances (feet)</i>		
				DES	SSSD	PROP
<b>Exiting Movements</b>	To the left	40	+1	538	319	<b>600</b>
	To the right	40	-4	460	352	<b>500+</b>
<b>Entering Left-Turns</b>	Approaching same direction	40	-4	N/A	352	<b>500+</b>
	Approaching opposite direction	40	+1	373	319	<b>400+</b>

DES = PennDOT Desirable Sight Distance

SSSD = PennDOT Safe Stopping Sight Distance

PROP = Proposed Sight Distance

1. Roadway Grade Approaching Site Access

N/A = Not Applicable

As shown in Table 2, the proposed sight distances at the proposed eastern site driveway will exceed the applicable PennDOT sight distance requirements in all cases.

Western Full-Access Site Driveway

Table 3 shows the proposed, desirable, and safe stopping sight distances at the western site driveway for vehicles entering and exiting the site.

**TABLE 3**  
**SIGHT DISTANCE ANALYSIS**  
**PROPOSED WESTERN SITE DRIVEWAY**

	<i>Direction</i>	Design Speed (mph)	Grade <sup>1</sup> (%)	<i>Sight Distances (feet)</i>		
				DES	SSSD	PROP
<b>Exiting Movements</b>	To the left	40	+1	538	319	<b>600+</b>
	To the right	40	-5	460	360	<b>500+</b>
<b>Entering Left-Turns</b>	Approaching same direction	40	-5	N/A	360	<b>500+</b>
	Approaching opposite direction	40	+1	373	319	<b>400+</b>

DES = PennDOT Desirable Sight Distance

SSSD = PennDOT Safe Stopping Sight Distance

PROP = Proposed Sight Distance

1. Roadway Grade Approaching Site Access

N/A = Not Applicable

As shown in Table 3, the proposed sight distances at the western site driveway will exceed the applicable PennDOT sight distance requirements in all cases.

## **PLANNED ROADWAY IMPROVEMENTS**

### **Non Site-Related Improvements**

Based on a review of the PennDOT 12-Year Plan, there are programmed roadway improvements scheduled for the Route 611 corridor in the vicinity of the proposed site. Based on conversations with PennDOT District 5-0, it is TPD's understanding these improvements will include resurfacing Route 611 from Fairview Avenue in Mount Pocono Borough to Woodland Road in Paradise Township. In conjunction with the resurfacing, left-turn lanes will be constructed along Route 611 at the intersections of Grange Road, Meadowside Road/Trinity Hill Road and Wiscasset Road. These improvements are currently scheduled during the first four-year period (October 2004 – September 2008) of the PennDOT 12-Year Plan. It is TPD's understanding that the improvements in Mount Pocono Borough will be completed in 2005, and the improvements in Paradise Township will be completed in 2006.

It is also TPD's understanding that the intersections of Route 940/Carlton Road/Caesar's Resort Driveway and Route 940/Route 390 are planned to be signalized. As part of the signalization of the intersection of Route 940/Route 390, the southbound Route 390 approach to the intersection will be reconfigured to form a "T" intersection, thus eliminating the bifurcation.

The above-outlined roadway improvements have been included in all future condition analysis (base and projected conditions).

### **Site-Related Improvements**

The following improvements are recommended in conjunction with redevelopment of the Mount Airy Lodge facility:

#### **Woodland Road**

Widen Woodland Road from Route 611 to Carlton Road (approximately 2 miles) as follows:

- Widen Woodland Road from a two-lane (20-22 foot wide roadway) to a three-lane, 40-foot wide curbed roadway from Route 611 to 500 feet east of the proposed eastern Mount Airy Lodge site drive. The third lane will be striped as a center left turn lane resulting in left turn lanes on Woodland Road at its intersections with the Pocono Mountain School District Driveway, Bowman Road, Meadowside Road, and two Mount Airy Lodge site driveways.
- Widen Woodland Road to provide 250-foot long right turn deceleration lanes with 100-foot long tapers on Woodland Road at its intersections with the Pocono Mountain School District Driveway, Bowman Road, Meadowside Road, and two Mount Airy Lodge site driveways.
- Widen Woodland Road from 225 feet east of the proposed eastern Mount Airy Lodge site drive to Carlton Road to provide 11-foot wide travel lanes and 5-foot shoulders. This section of Woodland Road will remain two lanes wide.
- Horizontal and vertical geometric and alignment improvements along sections of Woodland Road including realignment in some sections, and superelevation.

- It is recommended that the speed limit for Woodland Road be reduced from 40 mph to 35 mph from Route 611 to 225 feet east of the proposed eastern Mount Airy Lodge site drive as a result of the horizontal geometry and curbing proposed for the roadway. It is further recommended that advisory 25 mph speed limit signs be placed for the three horizontal curves between Bowman Road and Meadowside Road.

#### **Route 611 and Woodland Road/ Strickland's Road/Big Daddy's Driveway**

- Construct a separate 250-foot long left-turn lane, with a 100-foot long taper on the westbound Woodland Road approach to Route 611.
- Construct a 250-foot long right-turn lane, with a 100-foot long taper on the westbound Woodland Road approach to Route 611.
- Re-designate the existing westbound Woodland Road approach to Route 611 in order to provide a shared left/through travel lane.
- Construct a separate 350-foot long right-turn lane, with a 210-foot long taper on the northbound Route 611 approach to Woodland Road.
- Close the Strickland's Road approach to the Route 611/Woodland Road/Big Daddy's intersection, thus eliminating the 5-leg intersection.
- Install new traffic signal equipment (controller, mast arms, signal heads) at the intersection of Route 611 and Woodland Road/Big Daddy's Driveway in order to accommodate the proposed traffic signal phasing.

#### **Route 940 and Carlton Road**

- Construct a separate 100-foot long left-turn lane, with a 100-foot long taper on the westbound Route 940 approach to Carlton Road.

#### **Route 611 and Route 314 (Eastern Leg)**

- Increase the cycle length of the traffic signal from 80 seconds to 100 seconds during the weekday P.M. peak hour. It will be at the discretion of Pocono Township and PennDOT whether or not the cycle length of the traffic signal at the intersection should be modified.

The above-outlined roadway improvements have been included in all future condition analysis with redevelopment of the Mount Airy Lodge facility (projected conditions). The future lane configurations and intersection controls with redevelopment of the Mount Airy Lodge facility are shown in Figure 4.

#### **EXISTING TRAFFIC VOLUMES**

Manual traffic counts were conducted during the Friday evening (4:00-8:00 P.M.) and Saturday evening (3:00-7:00 P.M.) peak hours of adjacent street traffic at the following intersections:

- Route 611 and Route 314 (Eastern Leg);
- Route 611 and Route 314 (Western Leg);
- Route 611 and Woodland Road/Strickland's Road/Big Daddy's Driveway;
- Route 611 and Meadowside Road/Trinity Hill Road;

- Route 611 and Grange Road;
- Woodland Road and Pocono Mountain School District Driveway (2:00-8:00 P.M.);
- Woodland Road and Bowman Road;
- Woodland Road and Meadowside Road;
- Woodland Road and Carlton Road;
- Route 940 and Carlton Road/Caesar's Resort Driveway;
- Route 940 and Route 390;
- Route 940 and Route 191/Red Rock Road.

The counts were taken at fifteen-minute intervals on the following days:

- Friday, May 20, 2005 between 4:00-8:00 P.M.;
- Saturday, May 21, 2005 between 3:00-7:00 P.M.;
- Saturday, June 18, 2005 between 3:00-7:00 P.M.

The purpose of the counts was to determine the traffic volume and directional distribution of traffic currently using the roadways in the vicinity of the site. For a given peak traffic period, the "peak hour" consists of the four consecutive 15-minute intervals during which the highest traffic volumes occur.

The Existing Condition traffic volumes during the Friday P.M. and Saturday P.M. peak hours are shown in Figures 5 and 6, respectively.

In addition, the traffic volume map contained on the PennDOT Internet Traffic Monitoring System (ITMS) website was reviewed to determine the Average Daily Traffic (ADT) for a typical weekday along the State-maintained roadways in the vicinity of the proposed site. The ADT information from the ITMS website is summarized below in Table 4.

**TABLE 4  
AVERAGE DAILY TRAFFIC (ADT) IN VICINITY OF PROPOSED SITE**

Roadway	Average Daily Traffic for Typical Weekday <sup>1</sup>
Route 611	14,690 vehicles per day
Woodland Road	2,552 vehicles per day
Route 314 (East)	3,814 vehicles per day
Route 314 (West)	3,529 vehicles per day
Carlton Road	3,268 vehicles per day
Route 940	7,769 vehicles per day
Route 390	7,124 vehicles per day
Route 191	2,377 vehicles per day

1 = Based on data contained on the PennDOT Internet Traffic Monitoring System website

The manual traffic count printouts and PennDOT ITMS data sheets are included in Appendix B.

## **BASE CONDITIONS**

### **Background Growth**

A background growth factor for the roadways in the study area was developed based on information supplied by the PennDOT Bureau of Planning and Research (BPR). According to the BPR, growth values were determined utilizing an average of the last 9 years of growth information and comparing it to an average calculated from 9 years of historical growth. Based on the calculations, the PennDOT BPR recommends utilizing a background growth trend factor of 1.022 (2.2%) per year in Monroe County for Functional Class Groups (FCG) 4 and 6, pertaining to rural minor arterial roadways and rural major collector roadways, respectively. Therefore, base condition traffic volumes (assuming a no-build scenario) were developed for the opening year of 2007 using a background growth factor of 1.044 (2.2% per year increase compounded for two years) and for the design year of 2017 using a background growth factor of 1.298 (2.2% per year increase compounded for twelve years) to adjust existing Friday P.M. and Saturday P.M. peak hour traffic volumes.

### **Nearby Planned Developments**

Base (future no-build) traffic conditions were calculated to include traffic volumes from proposed developments which, though not operating under existing conditions, may be operating by the opening year of the proposed development (2007). Based on discussions with staff from Paradise Township, Mount Pocono Borough, Pocono Township and Stroud Township, the following thirteen (13) developments were considered in this study:

Pocono Mountain School District Elementary School, located in Paradise Township along the western side of Bowman Road, between Woodland Road and Upper Swiftwater Road. The development will consist of an elementary school which will accommodate up to 1,000 students. The traffic generated by this development was calculated based on the equations contained in the ITE manual Trip Generation for elementary school (ITE Land Use Code #520). The site-generated trips were distributed throughout the study area based on existing traffic patterns.

Tall Oaks Residential Development, located in Paradise Township along Grange Road, between Route 611 and Route 940. The development will consist of 26 single-family dwelling units. The traffic generated by this development was calculated based on the equations contained in the ITE manual Trip Generation for single-family detached housing (ITE Land Use Code #210). The site-generated trips were distributed throughout the study area based on existing traffic patterns.

Grange Road/Route 940 Residential Development, located in Paradise Township in the vicinity of the Grange Road and Route 940 intersection. The development will consist of 20 townhouse units. The traffic generated by this development was calculated based on the equations contained in the ITE manual Trip Generation for residential condominium/townhouse (ITE Land Use Code #230). The site-generated trips were distributed throughout the study area based on existing traffic patterns.



Lowe's Home Improvement Store & Hirshland Development, located in Mount Pocono Borough along Route 940 in the vicinity of Industrial Park Drive. The Lowe's development will consist of a 161,659 square foot Lowe's Home Improvement Store, three high turnover sit-down restaurants consisting of 6,750, 6,800 and 7,100 square feet, respectively and 8,800 square feet of retail space. The Hirshland development will consist of 39,200 square feet of retail space, a 5,884 square foot convenience store with gas pumps, a 4,200 square foot high turnover sit-down restaurant and a 4,658 square foot high turnover sit down restaurant. The traffic generated by this development and the distribution of site-generated trips were obtained from the TIS performed by TPD, dated March 20, 2003, revised June 30, 2005.

Pocono Country Place, located in Mount Pocono Borough along Route 611, to the north of Route 940. The development will consist of an additional 1,200 single family residential units which are expected to be built out over the next 10 years. The traffic generated by this development was calculated based on the equations contained in the ITE manual Trip Generation for single-family detached housing (ITE Land Use Code #210). The site-generated trips were distributed throughout the study area based on existing traffic patterns.

Green Springs Age-Qualified Residential Community, located on the western side of Route 611, opposite Grange Road. The development will consist of 436 age-qualified dwelling units. The traffic generated by this development was calculated based on the equations contained in the ITE manual Trip Generation for senior adult housing - detached (ITE Land Use Code #251). The site-generated trips were distributed throughout the study area based on existing traffic patterns.

Great Wolf Lodge, located in Pocono Township on the western side of Route 611, north of the I-80 Interchange. The development will consist of a 400 room lodge. The traffic generated by this development and the distribution of site-generated trips were obtained from the TIS performed by Borton-Lawson Engineering.

Crossroads Mall of the Poconos, located in Stroud Township along Route 611, opposite the Route 33 Interchange. The development will consist of 300,000 square feet of retail space, an 8,000 square foot high turnover sit-down restaurant, and a convenience store with 8 gas pumps (16 fueling positions). The traffic generated by this development and the distribution of site-generated trips were obtained from the TIS performed by Benchmark Civil Engineering Services, Inc., dated March 14, 2003, revised December 15, 2004.

DEPG Stroud Associates, located in the vicinity of the proposed Crossroads Mall of the Poconos. The development will consist of a 5,615 square foot high turnover sit-down restaurant, a convenience store with 8 gas pumps (16 fueling positions), a hotel containing 105 rooms, and a 14,560 square foot pharmacy with drive-thru. The traffic generated by this development and the distribution of site-generated trips were obtained from the TIS performed by Benchmark Civil Engineering Services, Inc. for the Crossroads Mall of the Poconos, dated March 14, 2003, revised December 15, 2004.

Darlak Properties (Phase I), located in the vicinity of the proposed Crossroads Mall of the Poconos. The development will consist of 22,000 square feet of general office space and a hotel containing 105 rooms. The traffic generated by this development and the distribution of site-generated trips were obtained from the TIS performed by Benchmark Civil Engineering Services, Inc. for the Crossroads Mall of the Poconos, dated March 14, 2003, revised December 15, 2004.

Stroudsburg School District Middle School, located in the vicinity of the proposed Crossroads Mall of the Poconos. The development will consist of a middle school which will accommodate up to 1,200 students. The traffic generated by this development and the distribution of site-generated trips were obtained from the TIS performed by Benchmark Civil Engineering Services, Inc. for the Crossroads Mall of the Poconos, dated March 14, 2003, revised December 15, 2004.

Paradigm Development, located in the vicinity of the proposed Crossroads Mall of the Poconos. The development will consist of a 138,310 square feet of retail space. The traffic generated by this development and the distribution of site-generated trips were obtained from the TIS performed by Benchmark Civil Engineering Services, Inc. for the Crossroads Mall of the Poconos, dated March 14, 2003, revised December 15, 2004.

The background growth trend factor of 2.2% per year utilized to develop base condition traffic volumes accounts for traffic generated by the following nearby planned developments due to their location with respect to the Mount Airy Lodge, their type of land use, and the amount of traffic generated by the development:

Knobb Crest, located in Mount Pocono Borough along Knobb Road. The development will consist of 49 senior apartment units.

Geisinger Clinic, located in Mount Pocono Borough along Commerce Drive. The development will consist of an approximate 16,800 square foot clinic.

Industrial Site, located in Mount Pocono Borough along Commerce Drive. The development will consist of an approximately 70-acre industrial park.

Pocono Mountain Industrial Park, located in Mount Pocono Borough north of Route 940. The development will consist of an approximately 104-acre industrial park.

Summit Heights, located in Pocono Township along Summit Road. The development will consist of 8 single-family dwelling units.

The additional traffic volumes due to background growth and the thirteen (13) nearby planned developments were added to the existing traffic volumes to produce 2007 and 2017 Base Condition traffic volumes for the Friday P.M. and Saturday P.M. peak hours. The 2007 Base Condition traffic volumes for the Friday P.M. and Saturday P.M. peak hours are shown in Figures 7 and 8, respectively. The 2017 Base Condition traffic volumes for the Friday P.M. and Saturday P.M. peak

hours are shown in Figures 9 and 10, respectively. The trip distributions for the nearby planned developments are included in Appendix C.

**TRIP GENERATION**

Due to the lack of available data in the ITE Trip Generation Manual regarding this type of development, a Trip Generation Study for an existing similar facility was conducted to develop trip generation rates for the proposed facility. The similar existing facility studied, Dover Downs in Dover Delaware, currently consists of a 2,500 machine slot parlor including food and beverage support services, and a 232 room hotel.

**Dover Downs Trip Generation**

*Existing Trip Generation*

TPD conducted manual traffic counts at the existing site access driveways at the Dover Downs facility in Dover, Delaware. The counts were taken at 15-minute intervals from 4:00 P.M.-9:00 P.M. on Friday, April 29, 2005 and 11:00 A.M.-9:00 P.M. on Saturday, April 30, 2005. The purpose of the counts was to determine the existing trip generation of the facility, determine the peak traffic time periods of the facility, and develop trip generation rates for the P.M. peak hour of adjacent street traffic (one hour between 4:00-6:00 P.M. on a Friday) and on a peak generator hour basis for the existing facility for a typical Saturday. The Dover Downs manual traffic count printouts are included in Appendix D. Table 5 shows the existing trip generation of the Dover Downs facility for the Friday and Saturday peak hours.

**TABLE 5  
DOVER DOWNS - TRIP GENERATION**

<b>Time Period</b>	<b>Total</b>	<b>Enter</b>	<b>Exit</b>
Friday P.M. Peak Hour of Adjacent Street Traffic (5:15-6:15 P.M.)	851	496	355
Saturday Peak Hour of the Generator (5:15-6:15 P.M.)	941	523	418

*Trip Generation Rate Calculation*

Based on the information collected at the Dover Downs facility, as presented in Table 5, a trip generation rate was calculated to relate the number of trips generated during the peak hour time periods analyzed, to the number of slot machines at the existing facility (2,500). The directional distribution of traffic (enter/exit) was also calculated for each of the peak times. Table 6 shows the results of these calculations.

**TABLE 6  
DOVER DOWNS - TRIP GENERATION RATES**

Time Period	Trip Generation Rate	Directional Distribution	
		Enter	Exit
Friday P.M. Peak Hour of Adjacent Street Traffic	T = 0.34(X)	58%	42%
Saturday Peak Hour of the Generator	T = 0.38(X)	56%	44%

T = Total trips generated, X = # of Slot Machines

Mount Airy Lodge Proposed Trip Generation

The proposed Mount Airy Lodge facility will consist of a 3,000 machine slot parlor including food and beverage support services. It will also include a hotel with approximately 200 rooms. Therefore, since the proposed facility will have approximately the same number of slot machines, and approximately the same number of hotel rooms, the trip generation rates calculated from the counts performed at Dover Downs were utilized to develop the trip generation for the proposed Mount Airy Lodge. The proposed trip generation for the Mount Airy Lodge facility during the Friday and Saturday peak time periods is shown in Table 7.

**TABLE 7  
PROPOSED TRIP GENERATION – MOUNT AIRY LODGE FACILITY**

Time Period	X	R	Total	Enter	Exit
Friday P.M. Peak Hour of Adjacent Street Traffic	3,000	0.34	1,020	592	428
Saturday Peak Hour of the Generator	3,000	0.38	1,140	638	502

X = # of Slot Machines, R = Trip Generation Rate

**TRIP DISTRIBUTION**

The distribution of trips generated by the proposed Mount Airy Lodge was based on the local roadway network, the existing traffic patterns, the proposed use of the site, and a marketing study prepared for the Mount Airy Lodge. Based on the marketing study prepared for the Mount Airy Lodge, TPD prepared a trip distribution gravity model for an approximate 200-mile radius. Utilizing the results of the gravity model, the trips for the proposed development were distributed to the local roadway network based on the percentages shown in Table 8, and also shown in Figure 11. The results of the gravity model are contained in Appendix E.

**TABLE 8  
TRIP DISTRIBUTION PERCENTAGES**

Direction - To/From	Distribution %
North via 611	15%
North via Route 390	5%
South via Route 611	65%
South via Bowman Road	1%
South via Carlton Road	1%
West via Route 314	5%
East via Route 940	6%
West via Route 940	2%

The assignment of site-generated trips for the proposed development during the Friday P.M. and Saturday P.M. peak hours are shown in Figures 12 and 13, respectively.

**PROJECTED CONDITION TRAFFIC VOLUMES**

The site-generated trips were added to the 2007 and 2017 Base Condition traffic volumes to develop the 2007 and 2017 Projected Condition traffic volumes for the Friday P.M. and Saturday P.M. peak hours. The 2007 Projected Condition traffic volumes for the Friday P.M. and Saturday P.M. peak hours are shown in Figures 14 and 15, respectively. The 2017 Projected Condition traffic volumes for the Friday P.M. and Saturday P.M. peak hours are shown in Figures 16 and 17, respectively. These volumes include existing traffic, traffic due to thirteen (13) planned nearby developments, future “background” traffic growth, and all traffic due to the redevelopment of the Mount Airy Lodge facility.

**LEVELS OF SERVICE (LOS) FOR AN INTERSECTION**

For analysis of intersections, level of service is defined in terms of delay, which is a measure of driver discomfort and frustration, fuel consumption, and lost travel time. Level of service criteria is stated in terms of control delay per vehicle for a one-hour analysis period. Control delay includes initial deceleration delay, queue move-up time, stopped delay, and final acceleration delay. The criteria are shown in Table 9. Delay, as it relates to level of service, is a complex measure and is dependent upon a number of variables. For signalized intersections, these variables include the quality of vehicle progression, the cycle length, the green time ratio, and the volume/capacity ratio for the lane group in question. For unsignalized intersections, delay is related to the availability of gaps in the flow of traffic on the major street and the driver’s discretion in selecting an appropriate gap for a particular movement from the minor street (straight across, left or right turn).

**TABLE 9  
LEVEL OF SERVICE CRITERIA\***

Level of Service	Control Delay Per Vehicle (Seconds)	
	Signalized	Unsignalized
A	$\leq 10$	$\leq 10$
B	$> 10$ and $\leq 20$	$> 10$ and $\leq 15$
C	$> 20$ and $\leq 35$	$> 15$ and $\leq 25$
D	$> 35$ and $\leq 55$	$> 25$ and $\leq 35$
E	$> 55$ and $\leq 80$	$> 35$ and $\leq 50$
F	$> 80$	$> 50$

\* Obtained from the Transportation Research Board's Highway Capacity Manual, 2000 Edition.

### **CAPACITY ANALYSIS METHODOLOGY**

Capacity analyses were conducted for the Friday P.M and Saturday P.M. peak hours for the following intersections:

- Route 611 and Route 314 (Eastern Leg);
- Route 611 and Route 314 (Western Leg);
- Route 611 and Woodland Road/Strickland's Road/Big Daddy's Driveway;
- Route 611 and Meadowside Road/Trinity Hill Road;
- Route 611 and Grange Road;
- Woodland Road and Pocono Mountain School District Driveway;
- Woodland Road and Bowman Road;
- Woodland Road and Meadowside Road;
- Woodland Road and Carlton Road;
- Route 940 and Carlton Road/Caesar's Resort Driveway;
- Route 940 and Route 390;
- Route 940 and Route 191/Red Rock Road.

These analyses were conducted according to the methodologies contained in the 2000 Highway Capacity Manual (HCM) for the following conditions:

- Existing Conditions;
- 2007 Base Conditions (Future opening year without development);
- 2007 Projected Conditions (Future opening year with development);
- 2017 Base Conditions (Future design year without development);
- 2017 Projected Conditions (Future design year with development).

In addition, capacity analyses were conducted at the proposed site driveway intersections with Woodland Road under 2007 and 2017 Projected Conditions. The capacity analysis worksheets are included in Appendix F.

## **LEVELS OF SERVICE IN THE STUDY AREA**

### **Existing Conditions**

Existing Condition levels of service at the study area intersections are shown in Figures 18 and 19 for the Friday P.M. and Saturday P.M. peak hours, respectively.

### **2007 Base Conditions (Future Opening Year Without Development)**

The 2007 Base Condition traffic volumes were developed assuming a background growth factor of 1.044 (2.2% per year increase compounded for two years), traffic from thirteen (13) nearby planned developments, the non site-related improvements outlined in the Planned Roadway Improvements section of this report, and no development of the proposed site (the no-build scenario). The 2007 Base Condition levels of service at the study area intersections are shown in Figures 20 and 21 for the Friday P.M. and Saturday P.M. peak hours, respectively.

### **2007 Projected Conditions (Future Opening Year With Development)**

The 2007 Projected Condition traffic volumes were developed assuming a background growth factor of 1.044 (2.2% per year increase compounded for two years), traffic from thirteen (13) nearby planned developments, all of the improvements outlined in the Planned Roadway Improvements section of this report, and development of the proposed site (the build scenario). The 2007 Projected Condition levels of service at the study area intersections are shown in Figures 22 and 23 for the Friday P.M. and Saturday P.M. peak hours, respectively.

### **2017 Base Conditions (Future Design Year Without Development)**

The 2017 Base Condition traffic volumes were developed assuming a background growth factor of 1.298 (2.2% per year increase compounded for twelve years), traffic from thirteen (13) nearby planned developments, the non site-related improvements outlined in the Planned Roadway Improvements section of this report, and no development of the proposed site (the no-build scenario). The 2017 Base Condition levels of service at the study area intersections are shown in Figures 24 and 25 for the Friday P.M. and Saturday P.M. peak hours, respectively.

### **2017 Projected Conditions (Future Design Year With Development)**

The 2017 Projected Condition traffic volumes were developed assuming a background growth factor of 1.298 (2.2% per year increase compounded for twelve years), traffic from thirteen (13) nearby planned developments, all of the improvements outlined in the Planned Roadway Improvements section of this report, and development of the proposed site (the build scenario). The 2017 Projected Condition levels of service at the study area intersections are shown in Figures 26 and 27 for the Friday P.M. and Saturday P.M. peak hours, respectively.

Level of service matrices for the study area intersections are shown in Tables 10 and 11 for the Friday P.M. and Saturday P.M. peak hours, respectively.

**TABLE 10  
LEVEL OF SERVICE SUMMARY  
FRIDAY P.M. PEAK HOUR**

Intersection	Approach/ Movement		2005	2007	2007	2017	2017
			Existing	Base	Projected*	Base	Projected*
Route 611 & Route 314 (Eastern Leg)	WB	L	C	C	D	C	D
	WB	R	B	B	C	B	C
	NB	T/R	C	F (94.8)	F (88.9)	F (241.1)	F (233.5)
	SB	L	B	B	C	C	C
	SB	T	A	A	A	B	B
	<b>ILOS</b>		<b>B</b>	<b>D</b>	<b>D</b>	<b>F (122.5)</b>	<b>F (124.3)</b>
Route 611 & Route 314 (Western Leg)	EB	L	F	F	F	F	F
	EB	R	C	D	E	F	F
	NB	L	B	C	F	F	F
Route 611 & Woodland Road/ Strickland's Road/ Big Daddy's Driveway	EB	L/T/R	C	C	C	C	C
	WB	L	C	C	C	C	C
	WB	L/T			C		C
	WB	R			B		B
	NB	L	A	B	B	B	B
	NB	T	B	B	B	C	C
	NB	R			A		A
	SB	L	A	B	B	B	B
	SB	T/R	A	A	A	B	A
	SWB	L/T/R	C	D	---	D	---
	<b>ILOS</b>		<b>B</b>	<b>B</b>	<b>B</b>	<b>C</b>	<b>B</b>
Route 611 & Meadowside Road/ Trinity Hill Road	EB	L/T/R	B	B	B	B	B
	WB	L/T/R	C	D	D	E	E
	NB	L	A	B	B	B	B
	SB	L	A	B	B	B	B
Route 611 & Grange Road/ Green Springs Driveway	EB	L/T/R	-	F	F	F	F
	WB	L/T/R	C	F	F	F	F
	NB	L	-	B	B	B	B
	SB	L	A	B	B	B	B

\* = With Site-Related Recommendations



**TABLE 10 - CONTINUED**

Intersection	Approach/ Movement		2005	2007	2007	2017	2017
			Existing	Base	Projected*	Base	Projected*
Woodland Road & Pocono Mountain School Road	WB	L	A	A	A	A	A
	NB	L/R	B	B	C	B	C
Woodland Road & Bowman Road	WB	L	A	A	A	A	A
	NB	L/R	A	B	C	B	C
Woodland Road & Meadowside Road	EB	L	A	A	A	A	A
	SB	L/R	A	A	C	A	C
Woodland Road & Carlton Road	EB	L/T	B	B	B	B	C
	NB	L	A	A	A	A	A
Route 940 & Carlton Road/ Caesar's Resort Driveway	EB	L	A	B	B	B	C
	EB	T/R	---				
	WB	L	A	A	A	B	A
	WB	T/R			A		A
	NB	L/T/R	D	C	B	C	C
	SB	L/T/R	D	C	B	C	C
	<b>ILOS</b>		---	<b>B</b>	<b>B</b>	<b>C</b>	<b>B</b>
Route 940 & Route 390	EB	L	A	B	B	C	D
	EB	T	---				
	WB	T/R	---	B	B	B	B
	SB	L	B	D	D	D	D
	SB	R	B				
	<b>ILOS</b>		---	<b>C</b>	<b>C</b>	<b>C</b>	<b>D</b>
Route 940 & Route 191/ Red Rock Road	EB	L/T/R	A	A	A	A	A
	WB	L/T/R	A	A	A	A	A
	NB	L/T/R	B	C	C	C	C
	SB	L/T/R	C	C	C	E	E
Woodland Road & Eastern Site Driveway	WB	L	---	---	A	---	A
	NB	L	---	---	C	---	C
	NB	R	---	---	A	---	A
Woodland Road & Western Site Driveway	WB	L	---	---	A	---	A
	NB	L	---	---	D	---	D
	NB	R	---	---	B	---	B

\* = With Site-Related Recommendations

**TABLE 11  
LEVEL OF SERVICE SUMMARY  
SATURDAY P.M. PEAK HOUR**

Intersection	Approach/ Movement		2005	2007	2007	2017	2017
			Existing	Base	Projected*	Base	Projected*
Route 611 & Route 314 (Eastern Leg)	WB	L	C	C	D	C	D
	WB	R	C	C	C	C	C
	NB	T/R	A	B	B	C	C
	SB	L	A	A	B	B	C
	SB	T	A	A	A	A	A
	<b>ILOS</b>		<b>A</b>	<b>B</b>	<b>B</b>	<b>B</b>	<b>B</b>
Route 611 & Route 314 (Western Leg)	EB	L	D	F	F	F	F
	EB	R	B	B	C	C	C
	NB	L	A	B	C	B	C
Route 611 & Woodland Road/ Strickland's Road/ Big Daddy's Driveway	EB	L/T/R	C	C	C	C	C
	WB	L	D	C	C	C	C
	WB	L/T			C		C
	WB	R			B		B
	NB	L	A	A	B	A	B
	NB	T	A	B	C	B	C
	NB	R			A		A
	SB	L	A	A	B	A	B
	SB	T/R	A	A	A	A	A
	SWB	L/T/R	D	D	---	D	---
	<b>ILOS</b>		<b>A</b>	<b>A</b>	<b>B</b>	<b>B</b>	<b>B</b>
Route 611 & Meadowside Road/ Trinity Hill Road	EB	L/T/R	B	D	F	F	F
	WB	L/T/R	C	F	F	F	F
	NB	L	A	B	B	B	B
	SB	L	A	B	B	B	B
Route 611 & Grange Road/ Green Springs Driveway	EB	L/T/R	-	F	F	F	F
	WB	L/T/R	C	F	F	F	F
	NB	L	-	B	B	B	B
	SB	L	A	B	B	B	B

\* = With Site-Related Recommendations

**TABLE 11 - CONTINUED**

Intersection	Approach/ Movement		2005	2007	2007	2017	2017
			Existing	Base	Projected*	Base	Projected*
Woodland Road & Pocono Mountain School Road	WB	L	A	A	A	A	A
	NB	L/R	A	A	B	A	C
Woodland Road & Bowman Road	WB	L	A	A	A	A	A
	NB	L/R	A	A	C	A	C
Woodland Road & Meadowside Road	EB	L	A	A	A	A	A
	SB	L/R	A	A	C	A	C
Woodland Road & Carlton Road	EB	L/T	B	B	B	B	B
	NB	L	A	A	A	A	A
Route 940 & Carlton Road/ Caesar's Resort Driveway	EB	L	A	B	B	B	B
	EB	T/R	---				
	WB	L	A	A	A	B	A
	WB	T/R			A		A
	NB	L/T/R	C	C	B	C	B
	SB	L/T/R	B	B	B	C	B
	<b>ILOS</b>		---	<b>B</b>	<b>B</b>	<b>B</b>	<b>B</b>
Route 940 & Route 390	EB	L	A	B	B	C	C
	EB	T	---				
	WB	T/R	---	B	B	B	B
	SB	L	B	C	C	D	D
	SB	R					
	<b>ILOS</b>		---	<b>B</b>	<b>B</b>	<b>C</b>	<b>C</b>
Route 940 & Route 191/ Red Rock Road	EB	L	A	A	A	A	A
	WB	L	A	A	A	A	A
	NB	L/T/R	B	C	C	C	C
	SB	L/T/R	B	C	C	E	E
Woodland Road & Eastern Site Driveway	WB	L	---	---	A	---	A
	NB	L	---	---	C	---	C
	NB	R	---	---	A	---	A
Woodland Road & Western Site Driveway	WB	L	---	---	A	---	A
	NB	L	---	---	C	---	D
	NB	R	---	---	A	---	A

\* = With Site-Related Recommendations

As shown in Tables 10 and 11, under 2007 Projected Conditions, all approaches and turning movements at the study area intersections will operate at LOS D or better during the Friday P.M. and Saturday P.M. peak hours, except for the following:

Route 611 and Route 314 (Eastern Leg)

- Under 2007 and 2017 Projected Conditions, the northbound Route 611 through/right movement at Route 314 (Eastern Leg) will continue to operate at LOS F during the Friday P.M. peak hour. (Same LOS as 2007 and 2017 Base Conditions)

The delay for the LOS F will decrease from 94.8 seconds under 2007 Base Conditions to 88.9 seconds under 2007 Projected Conditions, and will decrease from 241.1 seconds under 2017 Base Conditions to 233.5 seconds under 2017 Projected Conditions. Furthermore, the overall intersection will operate at LOS D under 2007 Projected Conditions and LOS F (124.3 seconds of delay) under 2017 Projected Conditions. The overall intersection delay will minimally increase by 1.8 under 2017 conditions, when compared to base conditions.

Route 611 and Route 314 (Western Leg)

- Under 2007 and 2017 Projected Conditions, the eastbound Route 314 (western leg) left-turn movement to Route 611 will continue to operate at LOS F during the Friday P.M. and Saturday P.M. peak hours. (Same LOS as 2007 and 2017 Base Conditions)
- Under 2007 Projected Conditions, the eastbound Route 314 (western leg) right-turn movement to Route 611 will operate at LOS E during the Friday P.M. peak hour. (LOS D under 2007 Base Conditions)
- Under 2017 Projected Conditions, the eastbound Route 314 (western leg) right-turn movement to Route 611 will continue to operate at LOS F during the Friday P.M. peak hour. (Same LOS as 2017 Base Conditions)
- Under 2007 and 2017 Projected Conditions, the northbound Route 611 left-turn movement to Route 314 (western leg) will operate at LOS F during the Friday P.M. peak hour. (LOS C under 2007 Base Conditions and Same LOS as 2017 Base Conditions)

As indicated in the Signal Warrant Analysis section of this report, traffic signal warrants are satisfied at the intersection of Route 611 and Route 314 (Western Leg). Therefore, an improvement scenario was analyzed in which a traffic signal would be installed at the intersection. The capacity analyses conducted for the signalized scenario assumed that the eastbound left-turn movement from Route 314 to Route 611 would be eliminated. This was assumed due to the fact that eliminating the left-turn movement would allow the signal phasing to operate in such a manner that northbound Route 611 through traffic would not be controlled by the traffic signal, and thus would never stop. Additionally, northbound Route 611 left-turn traffic to Route 314 would be controlled by a left-turn phase of the traffic signal with southbound Route 611 traffic stopping. By providing this signal phasing, the queue of vehicles on northbound Route 611 will not extend into the intersection of Route 611 and Route 314 (Eastern Leg) which is located approximately 1,100 feet south of the centerline of Route 314 (Western Leg). With signalization, under 2007 and 2017 Projected Conditions, all approaches and turning movements at the intersection would operate at LOS C or better during the Friday P.M. and Saturday P.M. peak hours. *It is recommended that this potential improvement option be*

*further discussed/investigated with Pocono Township and PennDOT to determine if it is feasible.*

Additional information regarding the potential signalization of the intersection of Route 611 and Route 314 (Western Leg) is included in Appendix G. This information includes traffic volumes and capacity analysis worksheets for the affected intersections along Route 611.

*Route 611 and Meadowside Road/Trinity Hill Road*

- Under 2007 and 2017 Projected Conditions, the eastbound Trinity Hill Road approach to Route 611 will operate at LOS F during the Saturday P.M. peak hour. (LOS D under 2007 Base Conditions and Same LOS as 2017 Base Conditions)
- Under 2007 Projected Conditions, the westbound Meadowside Road approach to Route 611 will operate at LOS F during the Saturday P.M. peak hour. (Same LOS as 2007 Base Conditions)
- Under 2017 Projected Conditions, the westbound Meadowside Road approach to Route 611 will operate at LOS E during the Friday P.M. peak hour and LOS F during the Saturday P.M. peak hour. (Same LOS as 2017 Base Conditions)

The only improvement that would improve the deficient levels of service for the stop-controlled approaches would be the installation of a traffic signal. However, as indicated in the Signal Warrant Analysis section of this report, traffic signal warrants are not currently satisfied, and will not be satisfied with development of the proposed site, and therefore a traffic signal could not be installed at this time.

*Route 611 and Grange Road/Green Springs Driveway*

- Under 2007 and 2017 Projected Conditions, the eastbound Green Springs Driveway approach to Route 611 will operate at LOS F during the Friday P.M. and Saturday P.M. peak hours. (Same LOS as 2007 and 2017 Base Conditions)
- Under 2007 and 2017 Projected Conditions, the westbound Grange Road approach to Route 611 will operate at LOS F during the Friday P.M. and Saturday P.M. peak hours. (Same LOS as 2007 and 2017 Base Conditions)

The only improvement that would improve the deficient levels of service for the stop-controlled approaches would be the installation of a traffic signal. However, as indicated in the Signal Warrant Analysis section of this report, traffic signal warrants are not currently satisfied, and will not be satisfied with development of the proposed site, and therefore a traffic signal could not be installed at this time.

*Route 940 and Route 191/Red Rock Road*

- Under 2017 Projected Conditions, the southbound Route 191 approach to Route 940 will operate at LOS E during the Friday P.M. and Saturday P.M. peak hours. (Same LOS as 2017 Base Conditions) It should be noted that an LOS E condition is often deemed acceptable for unsignalized intersections.

## SIGNAL WARRANT ANALYSIS

Preliminary traffic signal warrant analyses were conducted in accordance with PennDOT Publication 201, Engineering and Traffic Studies, Subchapter E, "Traffic Signals". TPD examined traffic volumes at the following intersections to determine if PennDOT Signal Warrant (xi), the Peak Hour Volume Warrant, is satisfied:

- Route 611 and Route 314 (Western Leg);
- Route 611 and Grange Road/Green Springs Driveway;
- Route 611 and Meadowside Road/Trinity Hill Road.

The signal warrant analyses were performed utilizing the guidelines contained in the 1989 Federal Manual on Uniform Traffic Control Devices (MUTCD). The PennDOT traffic signal warrants (67 PA Code, Chapter 201, Subsection E) utilize the same criteria as the MUTCD guidelines. The signal warrant analysis worksheets are shown in Appendix H.

### Route 611 and Route 314 (Western Leg)

Table 12 shows the peak hour Route 611 two-way traffic volumes and the corresponding Route 314 (Western Leg) threshold volume required to satisfy the peak hour signal warrant based on a table in Publication 201, Subchapter E, Warrant (xi), Section B.

**TABLE 12  
PEAK HOUR SIGNAL WARRANT ANALYSIS  
ROUTE 611 AND ROUTE 314 (WESTERN LEG)**

Condition	Peak Hour	Major Street	Minor Streets	Threshold Volume	Warrant Satisfied?
		Route 611*	Grange Road/ Driveway		
		Two-way			
Existing	Friday P.M. Peak	1,759	141	100	Yes
	Saturday P.M. Peak	1,473	113	100	Yes
2007 Base	Friday P.M. Peak	2,467	175	100	Yes
	Saturday P.M. Peak	2,275	153	100	Yes
2007 Projected	Friday P.M. Peak	3,049	205	100	Yes
	Saturday P.M. Peak	2,927	185	100	Yes
2017 Base	Friday P.M. Peak	2,914	211	100	Yes
	Saturday P.M. Peak	2,653	182	100	Yes
2017 Projected	Friday P.M. Peak	3,496	241	100	Yes
	Saturday P.M. Peak	3,305	214	100	Yes

\*Posted Speed = 45 mph

As shown in Table 12, Warrant (xi) **is satisfied** under all conditions at the intersection of Route 611 and Route 314 (Western Leg).

Route 611 and Grange Road/Green Springs Driveway

Table 13 shows the peak hour Route 611 two-way traffic volumes and the corresponding Grange Road/Green Springs Driveway threshold volume required to satisfy the peak hour signal warrant based on a table in Publication 201, Subchapter E, Warrant (xi), Section B.

**TABLE 13  
PEAK HOUR SIGNAL WARRANT ANALYSIS  
ROUTE 611 AND GRANGE ROAD/GREEN SPRINGS DRIVEWAY**

Condition	Peak Hour	Major Street	Minor Streets	Threshold Volume	Warrant Satisfied?
		Route 611*	Grange Road/ Driveway		
		Two-way			
Existing	Friday P.M. Peak	1,466	9	75	No
	Saturday P.M. Peak	1,259	23	75	No
2007 Base	Friday P.M. Peak	2,130	44	75	No
	Saturday P.M. Peak	1,999	61	75	No
2007 Projected	Friday P.M. Peak	2,283	44	75	No
	Saturday P.M. Peak	2,170	61	75	No
2017 Base	Friday P.M. Peak	2,503	44	75	No
	Saturday P.M. Peak	2,316	61	75	No
2017 Projected	Friday P.M. Peak	2,656	44	75	No
	Saturday P.M. Peak	2,487	61	75	No

\*Posted Speed = 45 mph

As shown in Table 13, Warrant (xi) **is not satisfied** under any condition at the intersection of Route 611 and Grange Road/Green Springs Driveway.

Route 611 and Meadowside Road/Trinity Hill Road

Table 14 shows the peak hour Route 611 two-way traffic volumes and the corresponding Meadowside Road/Trinity Hill Road threshold volume required to satisfy the peak hour signal warrant based on a table in Publication 201, Subchapter E, Warrant (xi), Section B.

**TABLE 14**  
**PEAK HOUR SIGNAL WARRANT ANALYSIS**  
**ROUTE 611 AND MEADOWSIDE ROAD/TRINITY HILL ROAD**

Condition	Peak Hour	Major Street	Minor Streets	Threshold Volume	Warrant Satisfied?
		Route 611*	Meadowside Road/ Trinity Hill Road		
		Two-way			
Existing	Friday P.M. Peak	1,450	12	75	No
	Saturday P.M. Peak	1,265	17	75	No
2007 Base	Friday P.M. Peak	2,106	12	75	No
	Saturday P.M. Peak	2,015	17	75	No
2007 Projected	Friday P.M. Peak	2,255	16	75	No
	Saturday P.M. Peak	2,180	23	75	No
2017 Base	Friday P.M. Peak	2,475	15	75	No
	Saturday P.M. Peak	2,333	22	75	No
2017 Projected	Friday P.M. Peak	2,624	19	75	No
	Saturday P.M. Peak	2,498	28	75	No

\*Posted Speed = 45 mph

As shown in Table 14, Warrant (xi) **is not satisfied** under any condition at the intersection of Route 611 and Meadowside Road/Trinity Hill Road.

**AUXILIARY LANE ANALYSIS**

*Left-Turn Lane*

TPD performed analyses at the proposed site driveway intersections using Highway Research Record (HRR) 211, which is the standard reference used by PennDOT and the “AASHTO Green Book”, to determine if left-turn lane warrants will be satisfied. In HRR 211, the following variables are taken into account to determine the need for a left-turn lane:

- $V_A$  = advancing volume (through, left-turning, and right-turning vehicles, vph);
- $V_L$  = left-turning volume (vph);
- $L = V_L/V_A$  proportion of left turns in the total advancing traffic stream;
- $V_O$  = opposing volume (opposing through and right-turning vehicles, vph);
- $v$  = operating speed (mph).

*Right-Turn Deceleration Lane*

TPD performed analyses at the proposed site driveway intersections using the National Cooperative Highway Research Program (NCHRP) Report 279, Intersection Channelization Design Guide, 1985 to determine if right-turn deceleration lane warrants will be satisfied. The NCHRP Report 279 gives guidelines for the addition of right-turn deceleration lanes at intersections in graphical form.



***Findings:***

***Woodland Road and Proposed Eastern Site Driveway***

Based on HRR 211, left-turn lane warrants are not satisfied at the proposed Woodland Road eastern site driveway intersection for vehicles entering the site via a left-turn movement. As outlined in the planned roadway improvements section of this report, a 100-foot long left-turn lane, with a 100-foot long taper will be provided at the eastern site driveway for vehicles entering the site via a left-turn movement.

Based on the NCHRP Report 279, guidelines indicate that a full-width turn lane and taper is required at the proposed Woodland Road eastern site driveway intersection. As outlined in the planned roadway improvements section of this report, a 250-foot long right-turn deceleration lane with a 100-foot long taper will be provided on the eastbound Woodland Road approach to the proposed eastern site driveway for vehicles entering the site via a right-turn movement.

***Woodland Road and Proposed Western Site Driveway***

Based on HRR 211, left-turn lane warrants are not satisfied at the proposed Woodland Road western site driveway intersection for vehicles entering the site via a left-turn movement. As outlined in the planned roadway improvements section of this report, a 100-foot long left-turn lane, with a 100-foot long taper will be provided at the western site driveway for vehicles entering the site via a left-turn movement.

Based on the NCHRP Report 279, guidelines indicate that a full-width turn lane and taper is required at the proposed Woodland Road western site driveway intersection. As outlined in the planned roadway improvements section of this report, a 250-foot long right-turn deceleration lane with a 100-foot long taper will be provided on the eastbound Woodland Road approach to the proposed western site driveway for vehicles entering the site via a right-turn movement.

The auxiliary turn-lane analysis worksheets are included in Appendix I.

**QUEUE LENGTH ANALYSIS**

Queue lengths at the study area intersections were analyzed using SYNCHRO to determine the 95<sup>th</sup> percentile queue lengths. The 95<sup>th</sup> percentile queue is the maximum back of queue with 95<sup>th</sup> percentile traffic volumes. The 95<sup>th</sup> percentile queue length is the queue exceeded at some point during 5% of the signal cycles.

The results of 95<sup>th</sup> percentile queue length analysis are contained in Appendix J.

## **RECOMMENDATIONS**

*TPD has made the following recommendations in relation to the proposed Mount Airy Lodge redevelopment in Paradise Township, Monroe County, Pennsylvania:*

### **Woodland Road**

*Widen Woodland Road from Route 611 to Carlton Road (approximately 2 miles) as follows:*

- *Widen Woodland Road from a two-lane (20-22 foot wide roadway) to a three-lane, 40-foot wide curbed roadway from Route 611 to 500 feet east of the proposed eastern Mount Airy Lodge site drive. The third lane will be striped as a center left turn lane resulting in left turn lanes on Woodland Road at its intersections with the Pocono Mountain School District Driveway, Bowman Road, Meadowside Road, and two Mount Airy Lodge site driveways.*
- *Widen Woodland Road to provide 250-foot long right turn deceleration lanes with 100-foot long tapers on Woodland Road at its intersections with the Pocono Mountain School District Driveway, Bowman Road, Meadowside Road, and two Mount Airy Lodge site driveways.*
- *Widen Woodland Road from 225 feet east of the proposed eastern Mount Airy Lodge site drive to Carlton Road to provide 11-foot wide travel lanes and 5-foot shoulders. This section of Woodland Road will remain two lanes wide.*
- *Horizontal and vertical geometric and alignment improvements along sections of Woodland Road including realignment in some sections, and superelevation.*
- *It is recommended that the speed limit for Woodland Road be reduced from 40 mph to 35 mph from Route 611 to 225 feet east of the proposed eastern Mount Airy Lodge site drive as a result of the horizontal geometry and curbing proposed for the roadway. It is further recommended that advisory 25 mph speed limit signs be placed for the three horizontal curves between Bowman Road and Meadowside Road.*

### **Route 611 and Woodland Road/ Strickland's Road/Big Daddy's Driveway**

- *Construct a separate 250-foot long left-turn lane, with a 100-foot long taper on the westbound Woodland Road approach to Route 611.*
- *Construct a 250-foot long right-turn lane, with a 100-foot long taper on the westbound Woodland Road approach to Route 611.*
- *Re-designate the existing westbound Woodland Road approach to Route 611 in order to provide a shared left/through travel lane.*
- *Construct a separate 350-foot long right-turn lane, with a 210-foot long taper on the northbound Route 611 approach to Woodland Road.*
- *Close the Strickland's Road approach to the Route 611/Woodland Road/Big Daddy's intersection, thus eliminating the 5-leg intersection.*

- *Install new traffic signal equipment (controller, mast arms, signal heads) at the intersection of Route 611 and Woodland Road/Big Daddy's Driveway in order to accommodate the proposed traffic signal phasing.*

#### Route 940 and Carlton Road

- *Construct a separate 100-foot long left-turn lane, with a 100-foot long taper on the westbound Route 940 approach to Carlton Road.*

#### Route 611 and Route 314 (Eastern Leg)

- *Increase the cycle length of the traffic signal from 80 seconds to 100 seconds during the weekday P.M. peak hour. It will be at the discretion of Pocono Township and PennDOT whether or not the cycle length of the traffic signal at the intersection should be modified.*

#### Route 611 and Route 314 (Western Leg)

- *Discuss/investigate the potential installation of a traffic signal at the intersection of Route 611 and Route 314 (Western Leg) with Pocono Township and PennDOT to determine if installing the traffic signal is feasible.*

### CONCLUSIONS

*The following conclusions were made as a result of this traffic impact study:*

- *Access to the proposed development will be provided by two (2) full-access site driveways to Woodland Road. The full-access site driveways will be located approximately 1,400 feet and 2,700 feet east of the centerline of Meadowside Road, respectively. The site driveways will be designed as high-volume driveways with two entering lanes and two exiting lanes, with proper channelization. In addition, left and right-turn lanes will be provided on the Woodland Road approaches to the site driveways.*
- *The proposed development will generate 1,020 new vehicle-trips during the Friday P.M. peak hour (approximately 17 new vehicle-trips every minute) and 1,140 new vehicle-trips during the Saturday P.M. peak hour (approximately 19 new vehicle-trips every minute).*
- *Future condition traffic volumes were calculated to include existing traffic, traffic due to thirteen (13) nearby planned developments, future "background" traffic growth, and all traffic due to the redevelopment of the Mount Airy Lodge facility.*
- *Analyses were conducted to determine the quality of operation (i.e. level of service) at the study area intersections for Existing, 2007 Base, 2017 Base, 2007 Projected, and 2017 Projected Conditions. Additional analyses were conducted at the site driveway intersections for 2007 and 2017 Projected Conditions.*
- *The improvements outlined in the recommendations section of this report should be implemented to improve future level of service deficiencies, offset level of service impacts, and to provide safe and efficient access to the proposed development.*

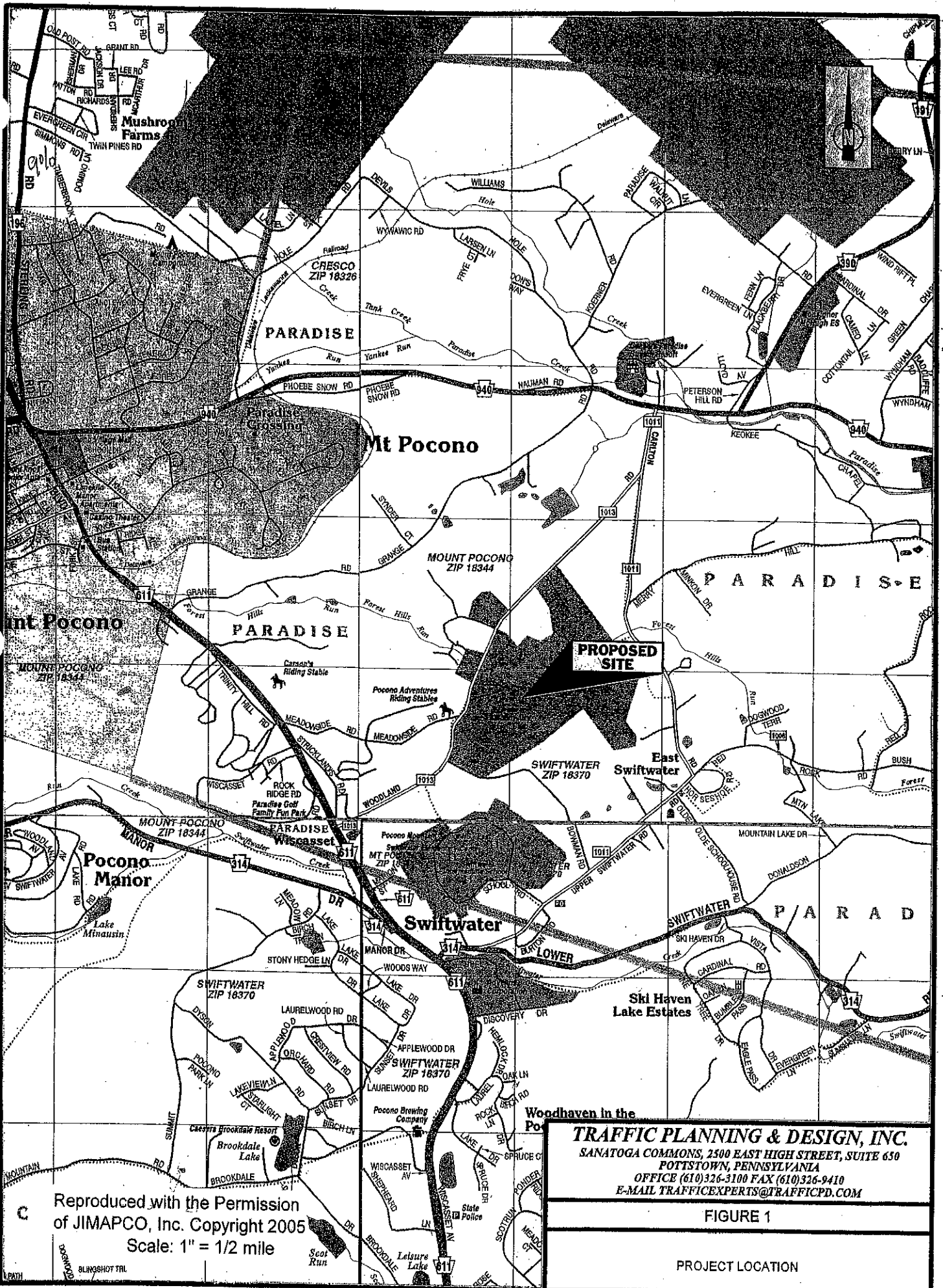

Reproduced with the Permission  
of JIMAPCO, Inc. Copyright 2005  
Scale: 1" = 1/2 mile

**TRAFFIC PLANNING & DESIGN, INC.**  
SANATOGA COMMONS, 2500 EAST HIGH STREET, SUITE 630  
POTTSTOWN, PENNSYLVANIA  
OFFICE (610)326-3100 FAX (610)326-9410  
E-MAIL TRAFFICEXPERTS@TRAFFICPD.COM

FIGURE 1

PROJECT LOCATION

**Proposed Mount Airy Lodge  
Resort and Casino**

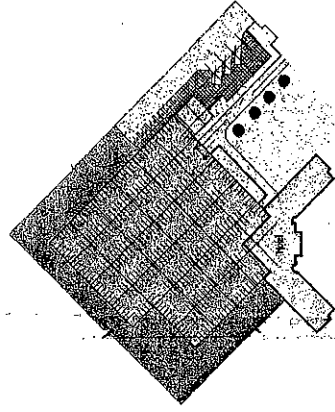

**Parking Garage Plan  
(under Proposed Casino)**

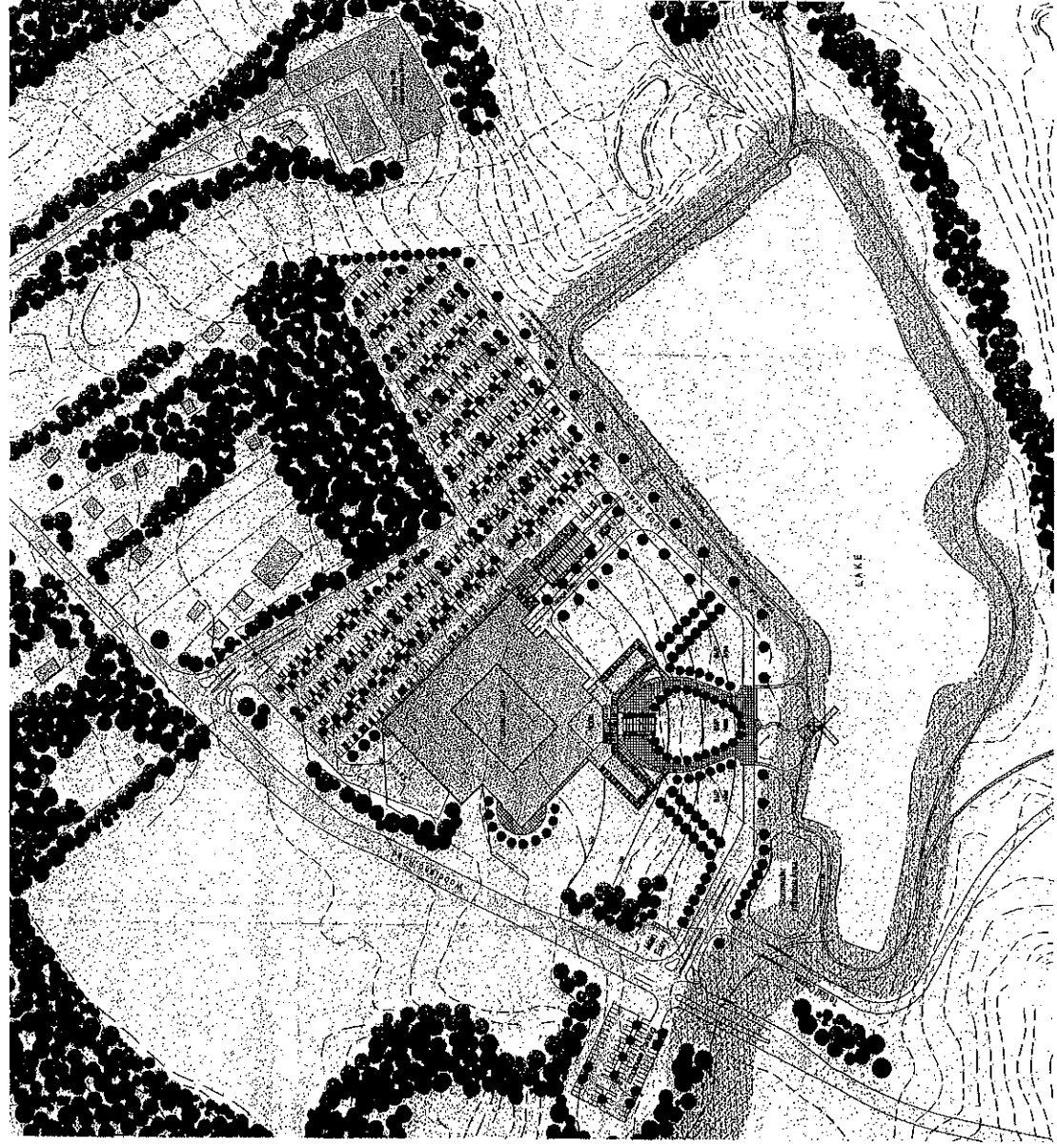

**Site Plan**

**TRAFFIC PLANNING & DESIGN, INC.**  
 SANATOGA COMMONS, 2500 EAST HIGH STREET, SUITE 630  
 POITTSWORN, PENNSYLVANIA 19464  
 OFFICE (610)334-3160 FAX (610)334-9410  
 467 SAUCON CREEK ROAD  
 CENTER VALLEY, PA 16834  
 OFFICE (717)234-4499 FAX (717)234-4696  
 E-MAIL TRAFFICPE@TRAFFICPD.COM

**FIGURE 2**

PROJECT SITE

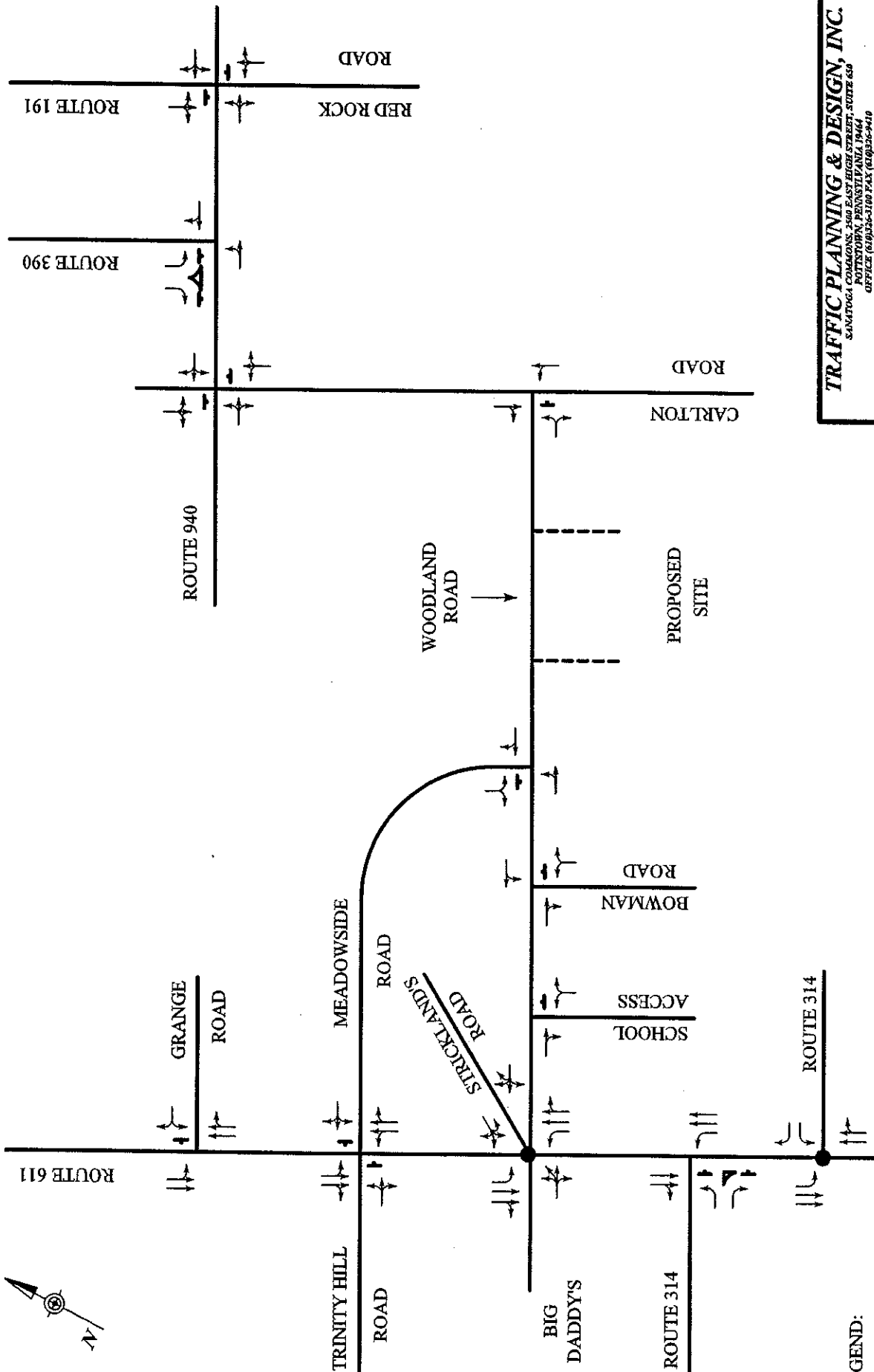

- LEGEND:**
- ⊥ = STOP CONTROL
  - = PLANNED SIGNAL CONTROL BY OTHERS
  - = EXISTING SIGNAL CONTROL
  - = PROPOSED SITE DRIVEWAY
- SCHMATIC DRAWING: NOT TO SCALE

**TRAFFIC PLANNING & DESIGN, INC.**  
 3467004 COTTLEMAN ROAD, SUITE 207-307-656  
 POTTSTOWN, PENNSYLVANIA 19441  
 OFFICE (610) 326-3100 FAX (610) 326-9410

467 SAUCON CREEK ROAD  
 CENTER VALLEY, PA 17004  
 OFFICE (717) 334-1400 FAX (717) 334-4490  
 E-MAIL: TRAFFICEXPERTS@TRAFFICPA.COM

**FIGURE 3**

EXISTING LANE CONFIGURATIONS  
 AND INTERSECTION CONTROLS

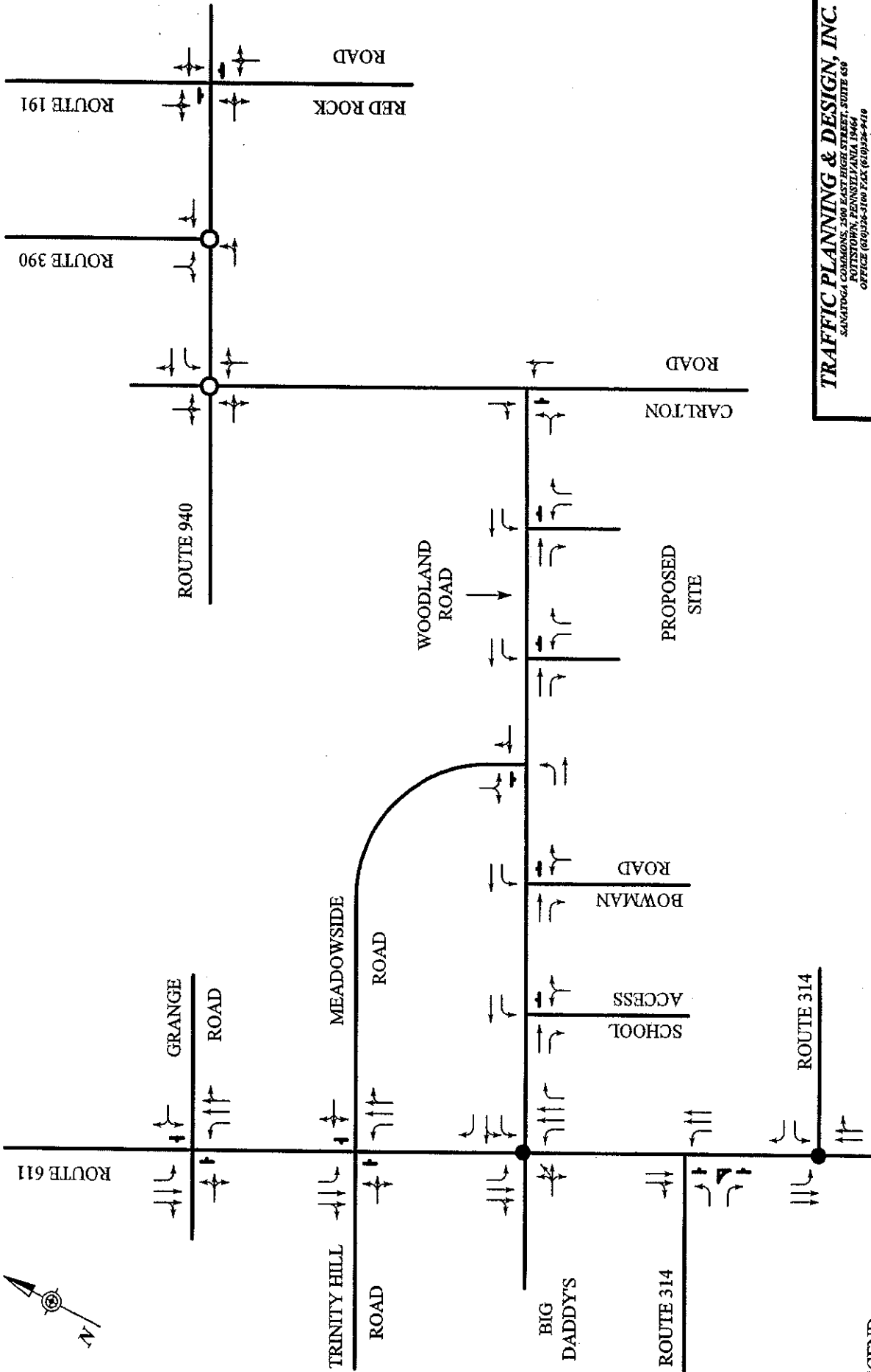
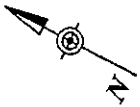

**LEGEND:**  
 T-junction symbol = STOP CONTROL  
 Circle with dot symbol = PLANNED SIGNAL CONTROL BY OTHERS  
 Solid dot symbol = EXISTING SIGNAL CONTROL  
 SCHEMATIC DRAWING: NOT TO SCALE

**TRAFFIC PLANNING & DESIGN, INC.**  
 SANATOGA COMMONS, 1500 EAST HIGH STREET, SUITE 610  
 POTTSTOWN, PENNSYLVANIA 19464  
 OFFICE (610) 326-3100 FAX (610) 324-9418  
 4617 SAUCON CREEK ROAD  
 CENTER VALLEY, PA 16834  
 OFFICE (610) 625-0412 FAX (610) 625-0250  
 HARRISBURG, PA 17110  
 OFFICE (610) 625-0412 FAX (610) 625-0250  
 E-MAIL TRAFFICEXPERTS@TRAFICPD.COM

FIGURE 4

FUTURE LANE CONFIGURATIONS AND INTERSECTION CONTROLS

**FRIDAY P.M. PEAK HOUR**

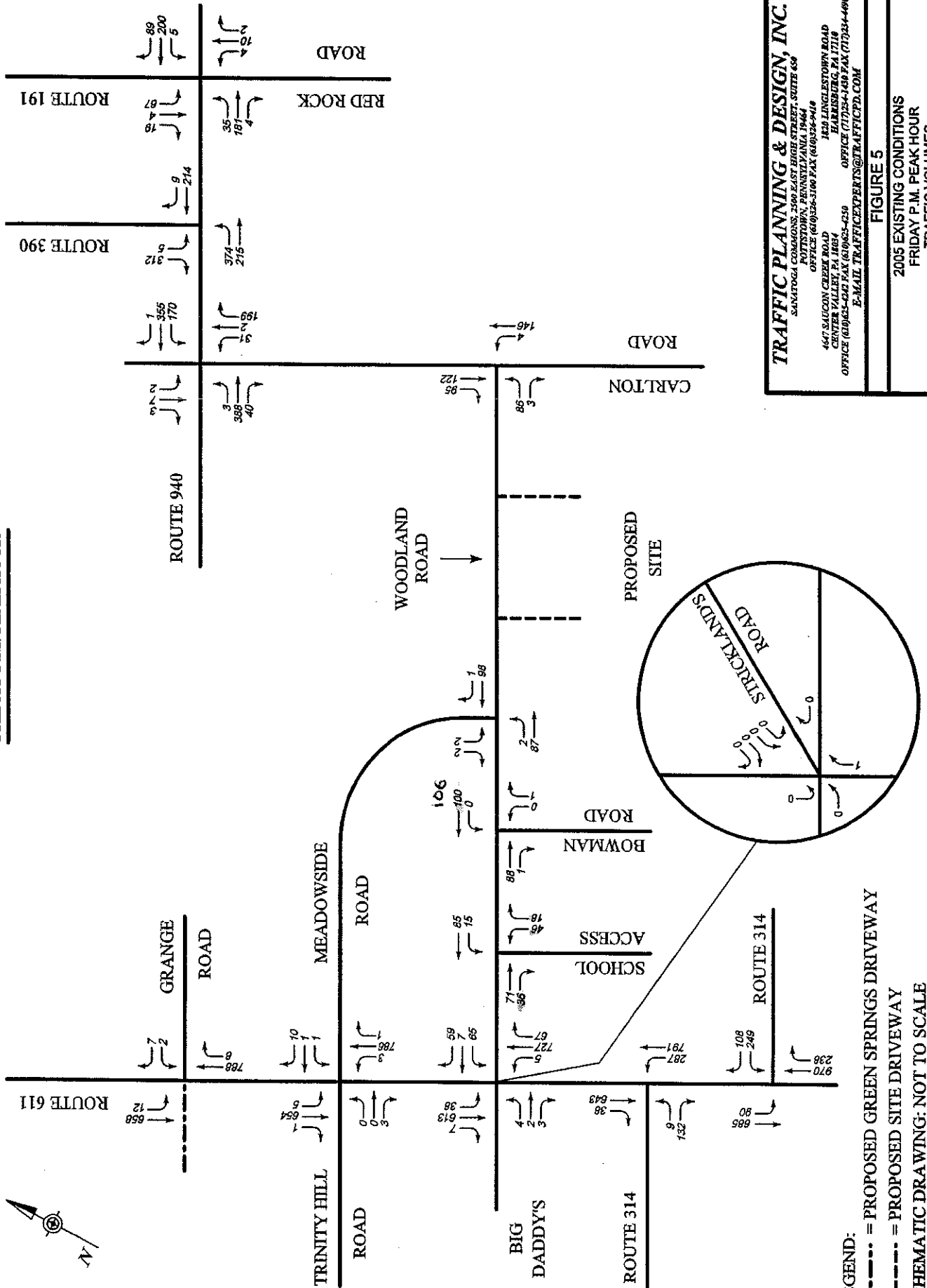

**LEGEND:**  
 - - - - - = PROPOSED GREEN SPRINGS DRIVEWAY  
 - - - - - = PROPOSED SITE DRIVEWAY  
 SCHEMATIC DRAWING: NOT TO SCALE

**TRAFFIC PLANNING & DESIGN, INC.**

SANITOGA COUNTY, 500 EAST HIGH STREET, SUITE 600  
 FORTSMITH, PENNSYLVANIA 16844  
 OFFICE (610)326-3100 FAX (610)326-9418  
 467 SAUCON CREEK ROAD  
 CENTER VALLEY, PA 16834  
 OFFICE (610)634-0242 FAX (610)634-0250  
 E-MAIL: TRAFFICEXPERTS@TRAFFICPD.COM

**FIGURE 5**  
 2005 EXISTING CONDITIONS  
 FRIDAY P.M. PEAK HOUR  
 TRAFFIC VOLUMES



**SATURDAY P.M. PEAK HOUR**

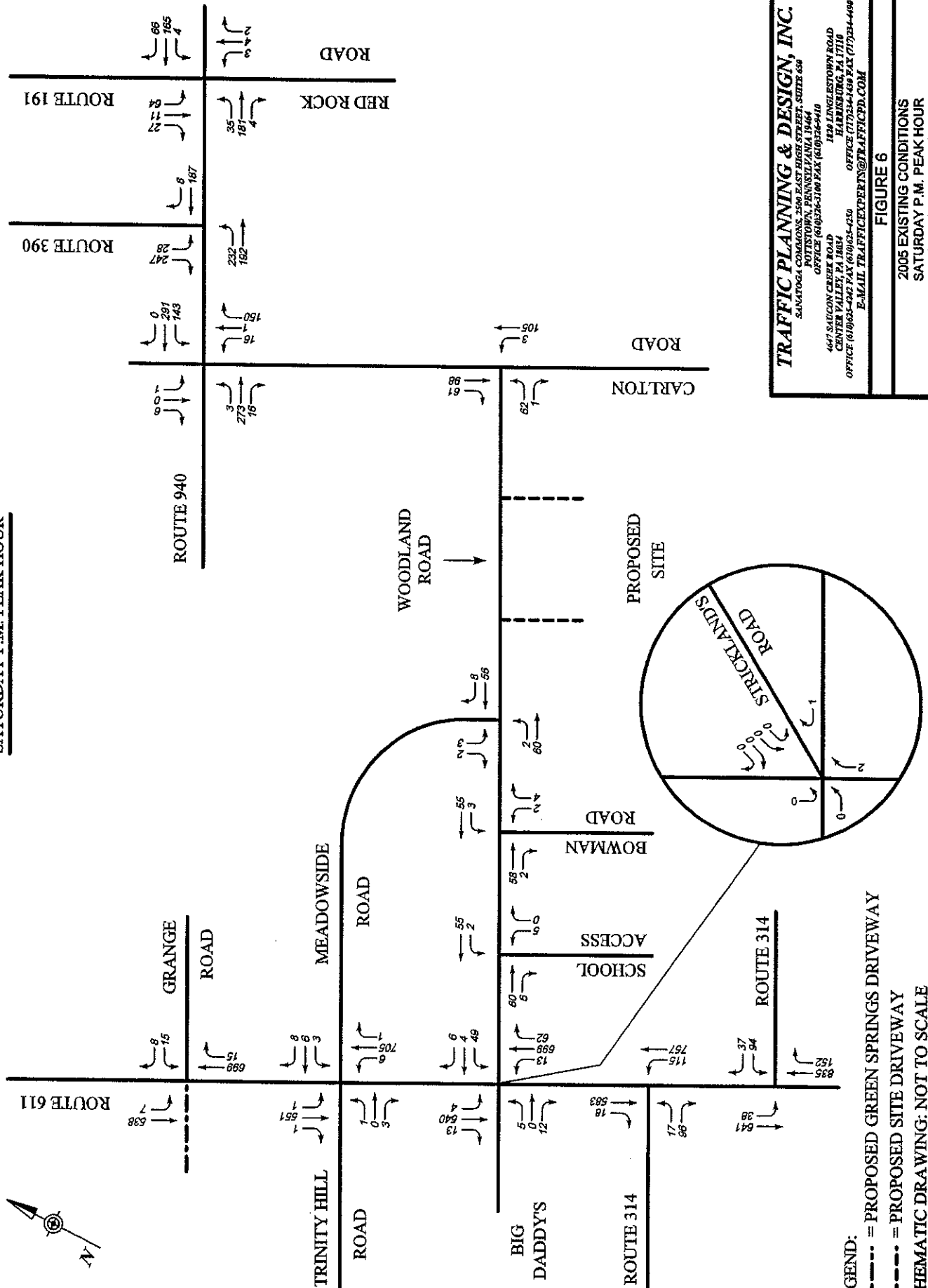

**TRAFFIC PLANNING & DESIGN, INC.**  
 SANATOGA COUNTY, PENNSYLVANIA, OFFICE: SUITE 609  
 1000 W. STATE ST. SUITE 609  
 PITTSBURGH, PENNSYLVANIA 15204  
 OFFICE (412) 326-3100 FAX (412) 326-9410  
 467 SAUCON CREEK ROAD  
 1820 LINGLESTOWN ROAD  
 CENTER VALLEY, PA 16834 HARRISBURG, PA 17116  
 OFFICE (717) 334-1458 FAX (717) 334-4998  
 OFFICE (412) 326-3100 FAX (412) 326-9410  
 E-MAIL: TRAFFICEXPERTS@TRAFFICPD.COM

**LEGEND:**  
 - - - - - = PROPOSED GREEN SPRINGS DRIVEWAY  
 - - - - - = PROPOSED SITE DRIVEWAY  
 SCHEMATIC DRAWING: NOT TO SCALE

**FIGURE 6**  
 2005 EXISTING CONDITIONS  
 SATURDAY P.M. PEAK HOUR  
 TRAFFIC VOLUMES

FRIDAY P. M. PEAK HOUR

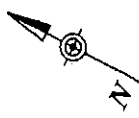
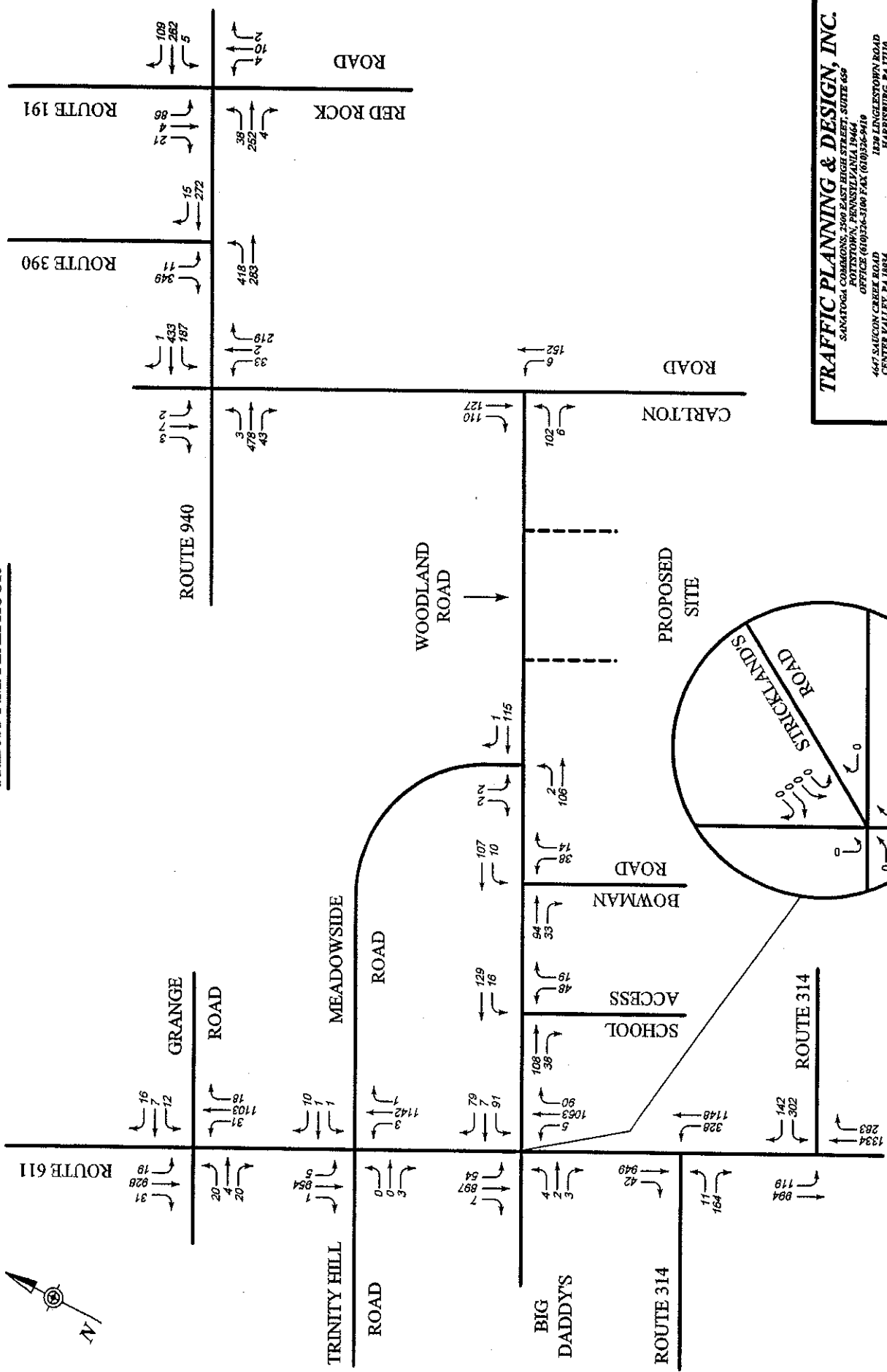

LEGEND:  
 - - - - - PROPOSED SITE DRIVEWAY  
 SCHEMATIC DRAWING: NOT TO SCALE

**TRAFFIC PLANNING & DESIGN, INC.**  
 SANATOGA CORPORAIONS, 2500 EAST HIGH STREET, SUITE 650  
 POTTSVILLE, PENNSYLVANIA 19464  
 OFFICE: (610)263-3100 FAX: (610)263-9119  
 4647 SALICORN CREEK ROAD  
 CENTER VALLEY, PA 16830  
 OFFICE: (717)854-4250  
 OFFICE: (717)854-4600 FAX: (717)854-4600  
 E-MAIL: TRAFFICEXPERTS@TRAFFICPD.COM

FIGURE 7

2007 BASE CONDITIONS  
 FRIDAY P. M. PEAK HOUR  
 TRAFFIC VOLUMES

SATURDAY P.M. PEAK HOUR

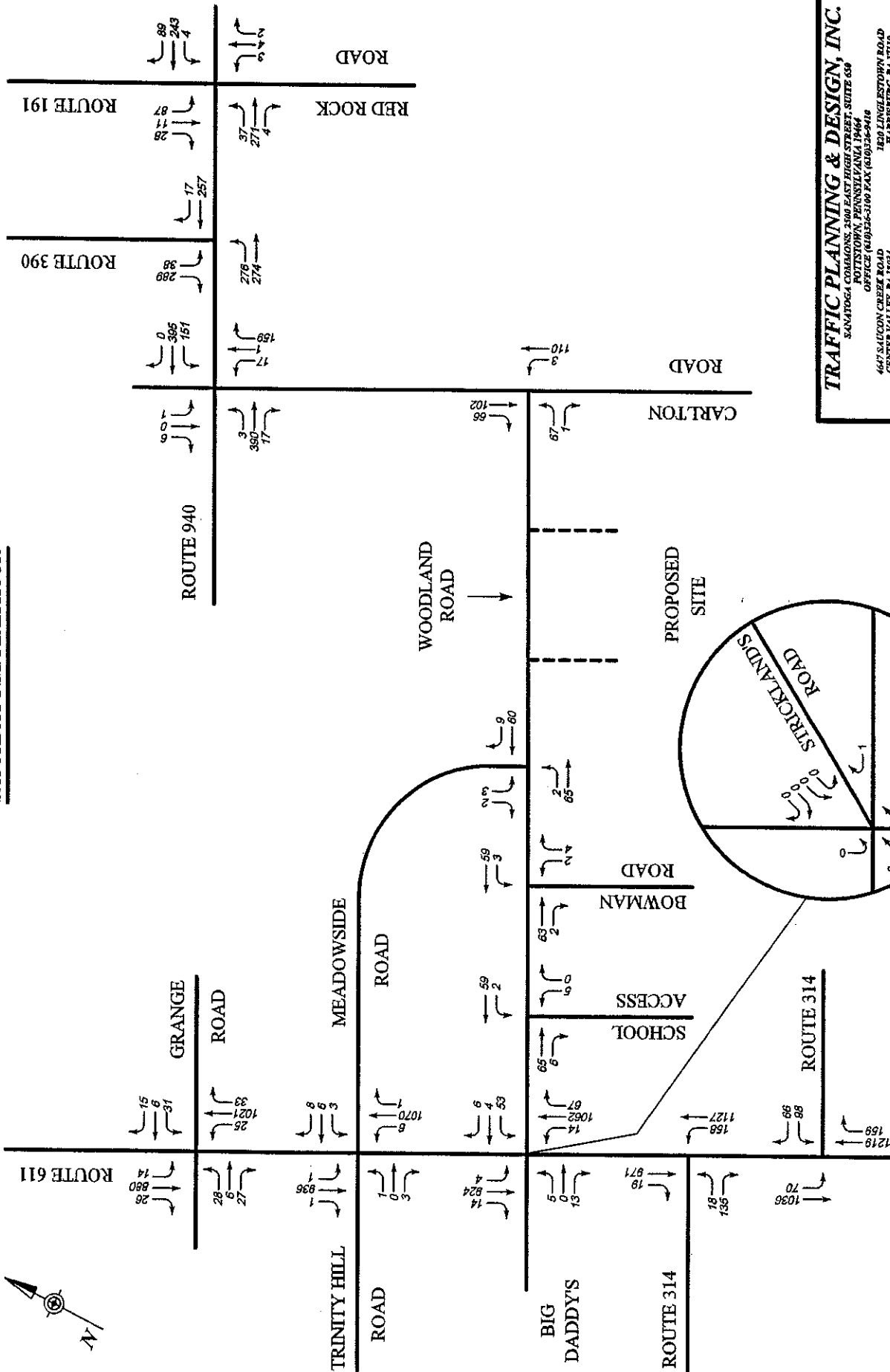

**TRAFFIC PLANNING & DESIGN, INC.**  
 SANATOGA COMMONS, 3500 EAST HIGH STREET, SUITE 609  
 POTTSTOWN, PENNSYLVANIA 19464  
 OFFICE (610)326-3100 FAX (610)326-9418  
 4647 SALICORN CREEK ROAD  
 CENTER VALLEY, PA 16834  
 OFFICE (810)631-4242 FAX (810)331-4250  
 E-MAIL: TRAFFICPEPERS@TRAFFICTD.COM

FIGURE 8

2007 BASE CONDITIONS  
 SATURDAY P.M. PEAK HOUR  
 TRAFFIC VOLUMES

LEGEND:  
 - - - - - = PROPOSED SITE DRIVEWAY  
 SCHEMATIC DRAWING: NOT TO SCALE

FRIDAY P.M. PEAK HOUR

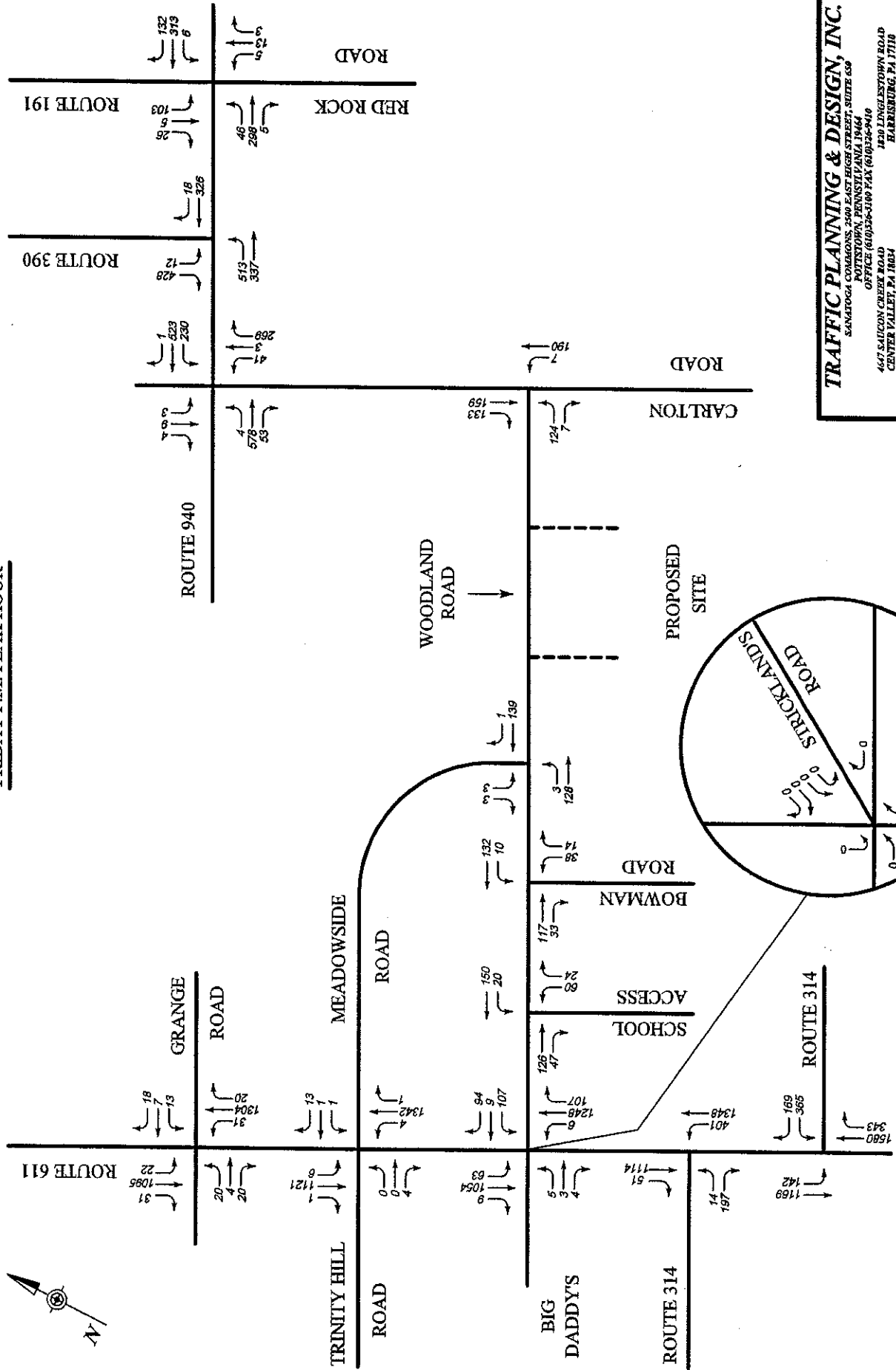

**TRAFFIC PLANNING & DESIGN, INC.**  
 3540 ROGERS COMMONS, 2500 EAST HIGH STREET, SUITE C30  
 HARRISBURG, PA 17110  
 OFFICE (610) 254-4499 FAX (610) 254-4499  
 4675 SAIGON CREEK ROAD  
 HARRISBURG, PA 17110  
 OFFICE (610) 254-4499 FAX (610) 254-4499  
 E-MAIL: TRAFFICEXPERTS@TRAFFICPD.COM

**LEGEND:**  
 - - - - - PROPOSED SITE DRIVEWAY  
 SCHEMATIC DRAWING: NOT TO SCALE

**FIGURE 9**  
 2017 BASE CONDITIONS  
 FRIDAY P.M. PEAK HOUR  
 TRAFFIC VOLUMES

SATURDAY P.M. PEAK HOUR

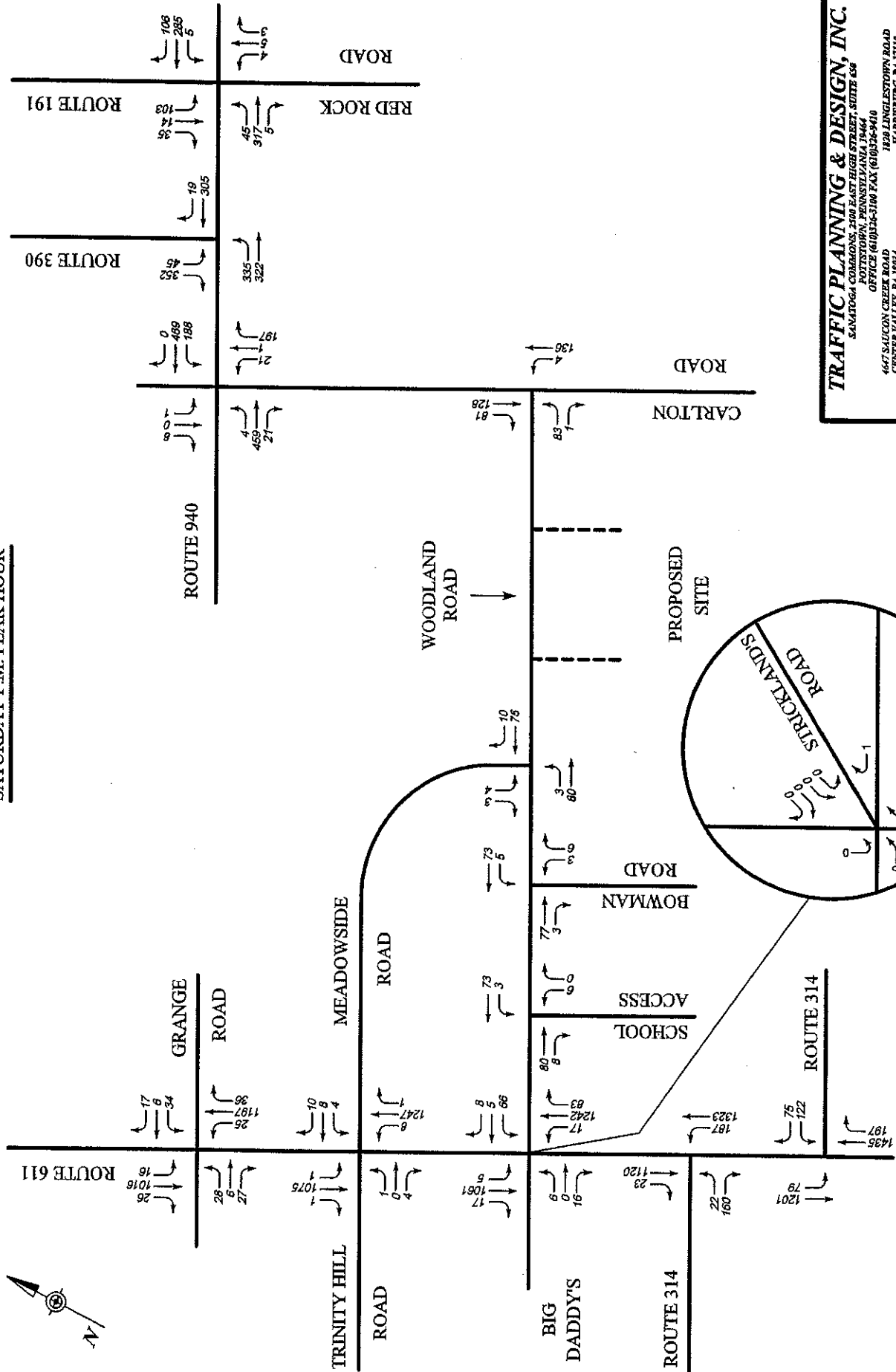

**TRAFFIC PLANNING & DESIGN, INC.**  
 SAMATOGA COMMONS, 200 EAST HIGH STREET, SUITE 630  
 FORT STODOL, PENNSYLVANIA 19444  
 OFFICE (610) 326-3100 FAX (610) 326-9410  
 4647 SALUCON CREEK ROAD  
 CHESTER, PENNSYLVANIA 17110  
 OFFICE (610) 651-7142 FAX (610) 651-6159 OFFICE (717) 326-1313 FAX (717) 326-4400  
 E-MAIL: TRAFFICEXPERTS@TRAFFICPD.COM

**FIGURE 10**  
 2017 BASE CONDITIONS  
 SATURDAY P.M. PEAK HOUR  
 TRAFFIC VOLUMES

**LEGEND:**  
 - - - - - = PROPOSED SITE DRIVEWAY  
 SCHEMATIC DRAWING: NOT TO SCALE

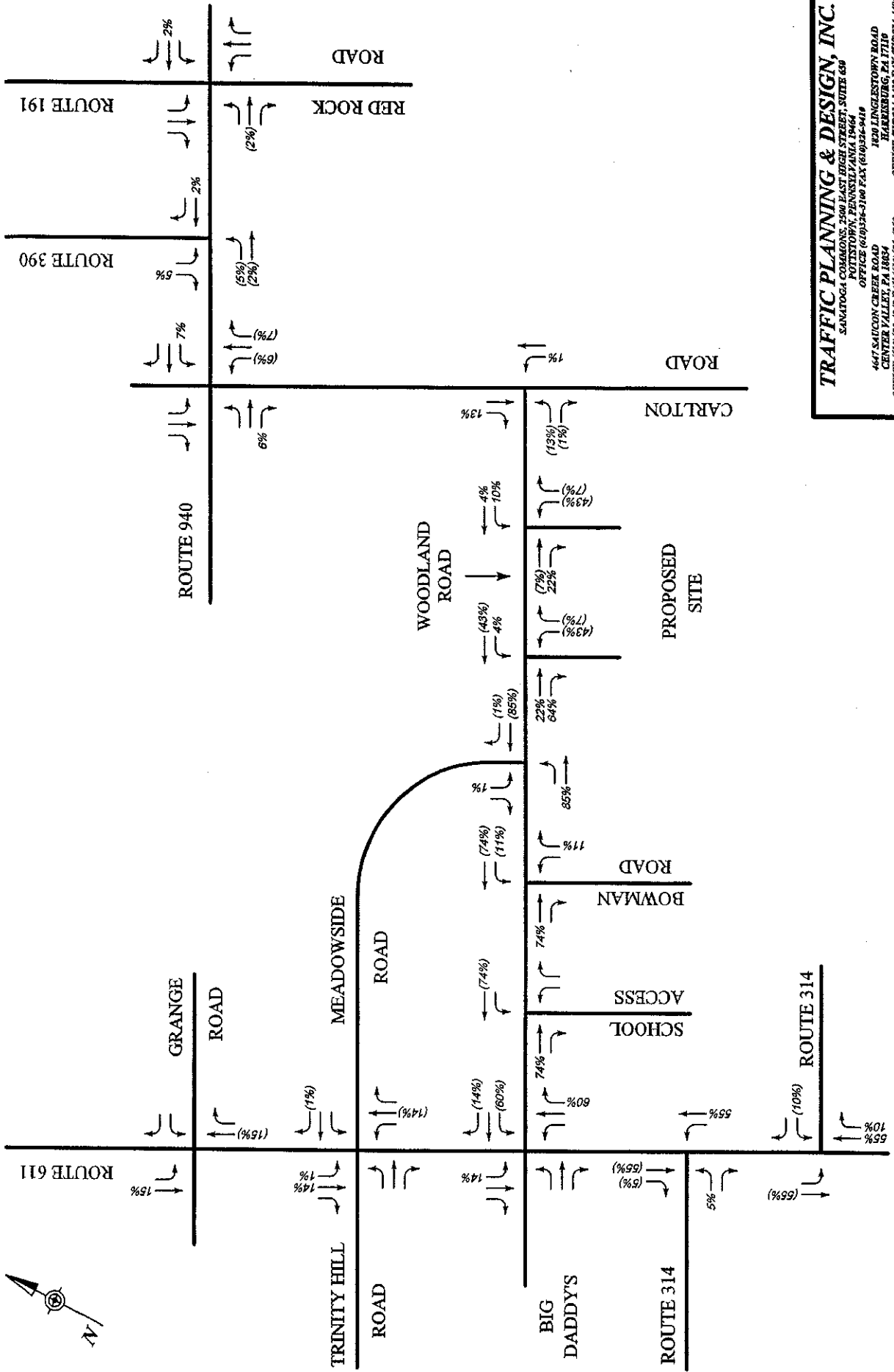
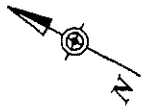

**TRAFFIC PLANNING & DESIGN, INC.**  
 SANATOGA COMMONS, 2500 EAST HIGH STREET, SUITE 450  
 POTTSTOWN, PENNSYLVANIA 19464  
 OFFICE (610)318-3100 FAX (610)318-9419  
 4647 SAUCON CREEK ROAD  
 CENTER VALLEY, PA 16854  
 OFFICE (814)933-4242 FAX (814)933-4230  
 E-MAIL TRAFFICEXPERTS@TRAFFICPD.COM

**LEGEND:**  
 ENTERING PERCENTAGE (EXITING PERCENTAGE)  
 SCHEMATIC DRAWING: NOT TO SCALE

**FIGURE 11**  
 TRIP DISTRIBUTION PERCENTAGES

FRIDAY P.M. PEAK HOUR

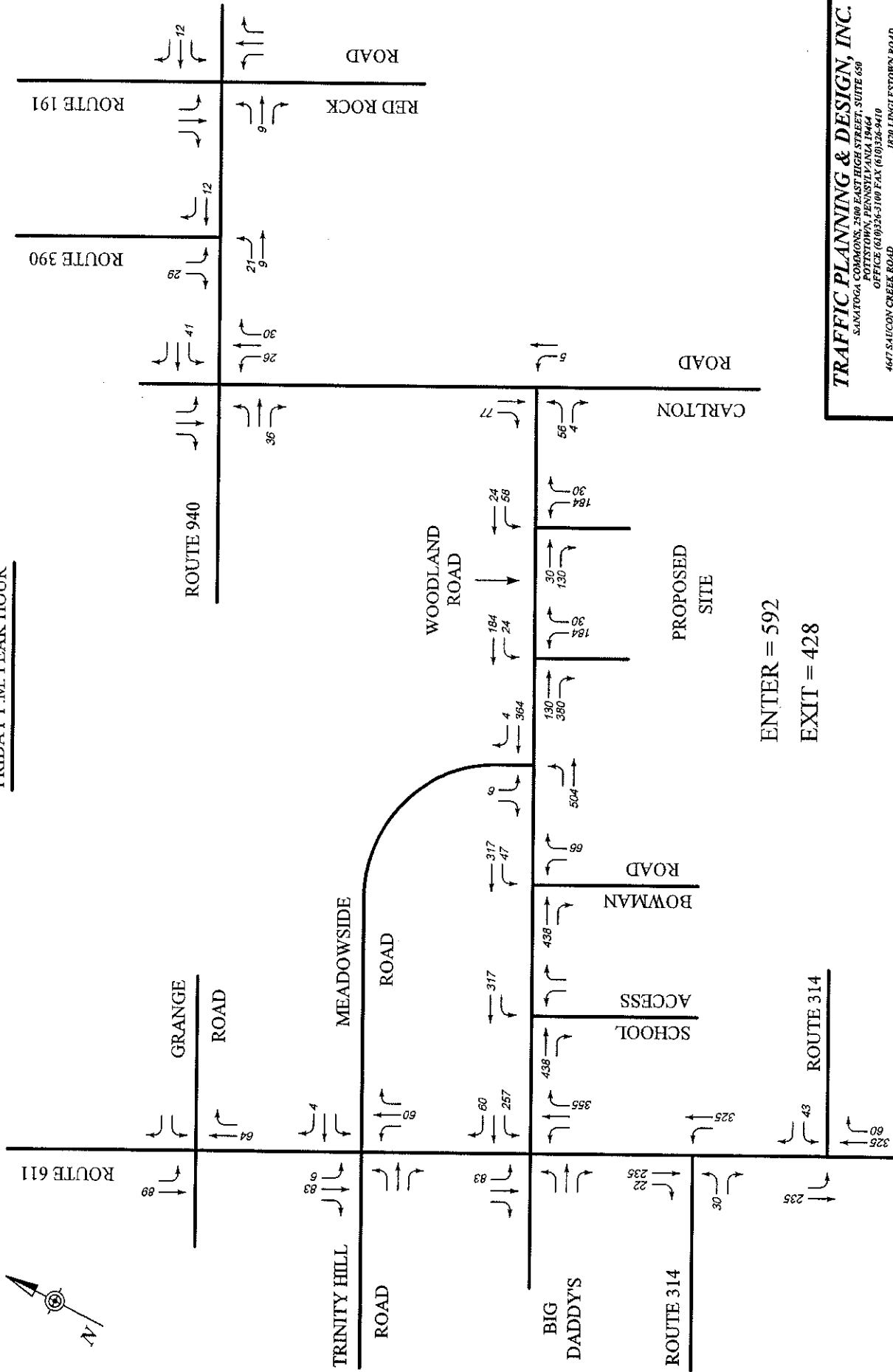

ENTER = 592  
EXIT = 428

**TRAFFIC PLANNING & DESIGN, INC.**  
 SEMATOGA COMMONS, 2300 EAST HIGH STREET, SUITE 650  
 ATLANTA, GEORGIA 30328  
 OFFICE (404) 336-1944  
 4647 SAUCON CREEK ROAD  
 CENTER VALLEY, PA 16834  
 OFFICE (717) 934-1480 FAX (717) 934-4980  
 E-MAIL TRAFFICPLANNING@TRAFFICPD.COM

FIGURE 12

TRIP DISTRIBUTION  
FRIDAY P.M. PEAK HOUR

SCHEMATIC DRAWING: NOT TO SCALE

SATURDAY P.M. PEAK HOUR

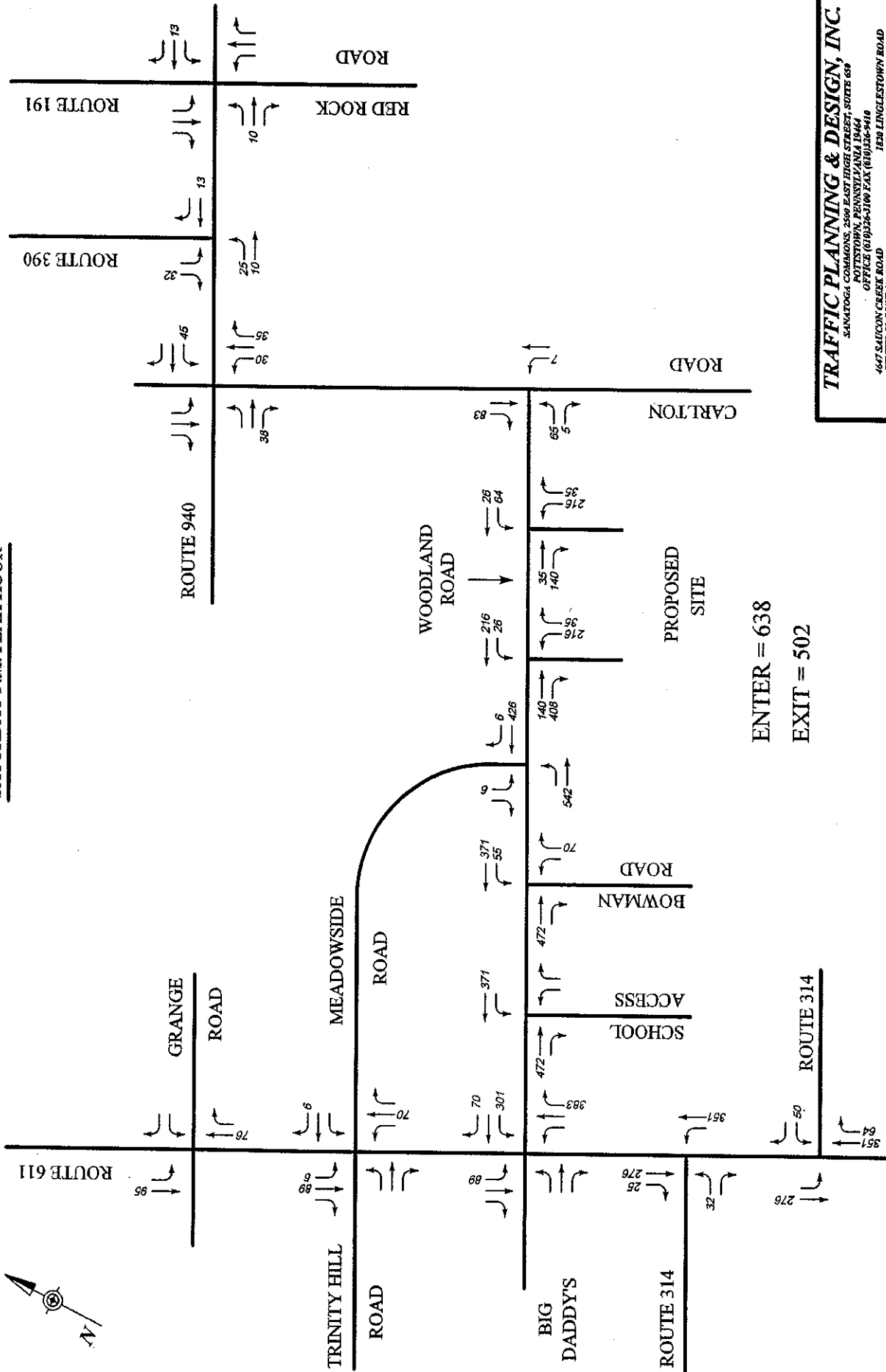

**TRAFFIC PLANNING & DESIGN, INC.**  
 3044 ROCK COMBONS, 25 WEST HIGHL STREET, SUITE 607  
 HARRISBURG, PA 17110  
 OFFICE (610) 263-1000 FAX (610) 263-9416  
 467 SAUCON CREEK ROAD  
 189 LINGLESTOWN ROAD  
 CENTER VALLEY, PA 17010  
 OFFICE (610) 261-4242 FAX (610) 263-4250  
 OFFICE (717) 234-1430 FAX (717) 234-4099  
 E-MAIL: TRAFFICEXPERTS@TRAFFICPD.COM

**FIGURE 13**

TRIP DISTRIBUTION  
 SATURDAY P.M. PEAK HOUR

SCHEMATIC DRAWING: NOT TO SCALE



**FRIDAY P.M. PEAK HOUR**

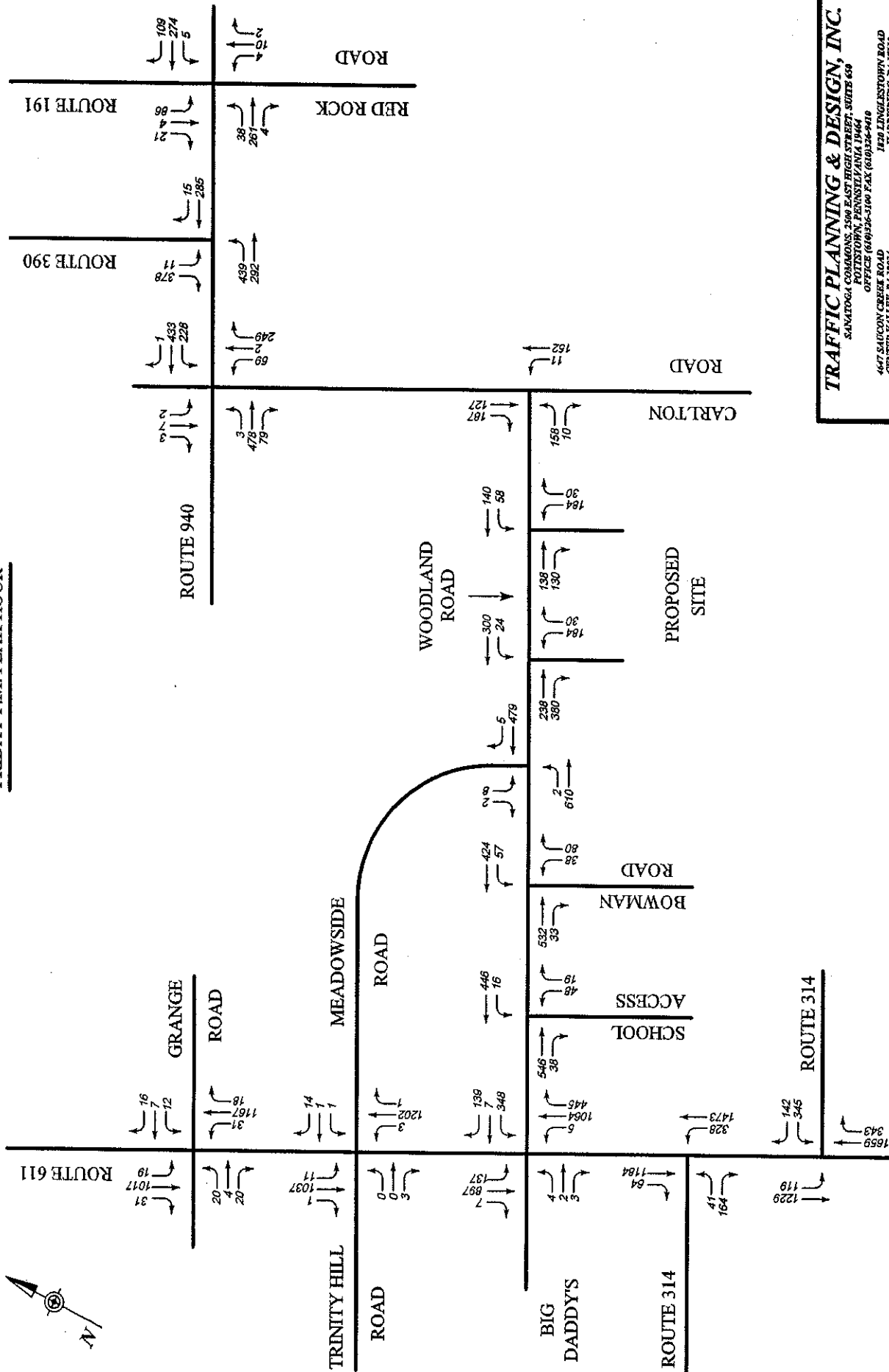

**TRAFFIC PLANNING & DESIGN, INC.**  
 SANATOGA COMMONS, 3500 EAST HIGH STREET, SUITE 600  
 POTTSVILLE, PENNSYLVANIA 17854  
 OFFICE (610)326-3100 FAX (610)326-9410  
 4647 SAUCON CREEK ROAD  
 CENTER VALLEY, PA 17019  
 OFFICE (717)234-1400 FAX (717)234-4100  
 E-MAIL: TRAFFICEXPERTS@TRAFFICPD.COM

**FIGURE 14**

2007 PROJECTED CONDITIONS  
 FRIDAY P.M. PEAK HOUR  
 TRAFFIC VOLUMES

SCHEMATIC DRAWING: NOT TO SCALE

SATURDAY P.M. PEAK HOUR

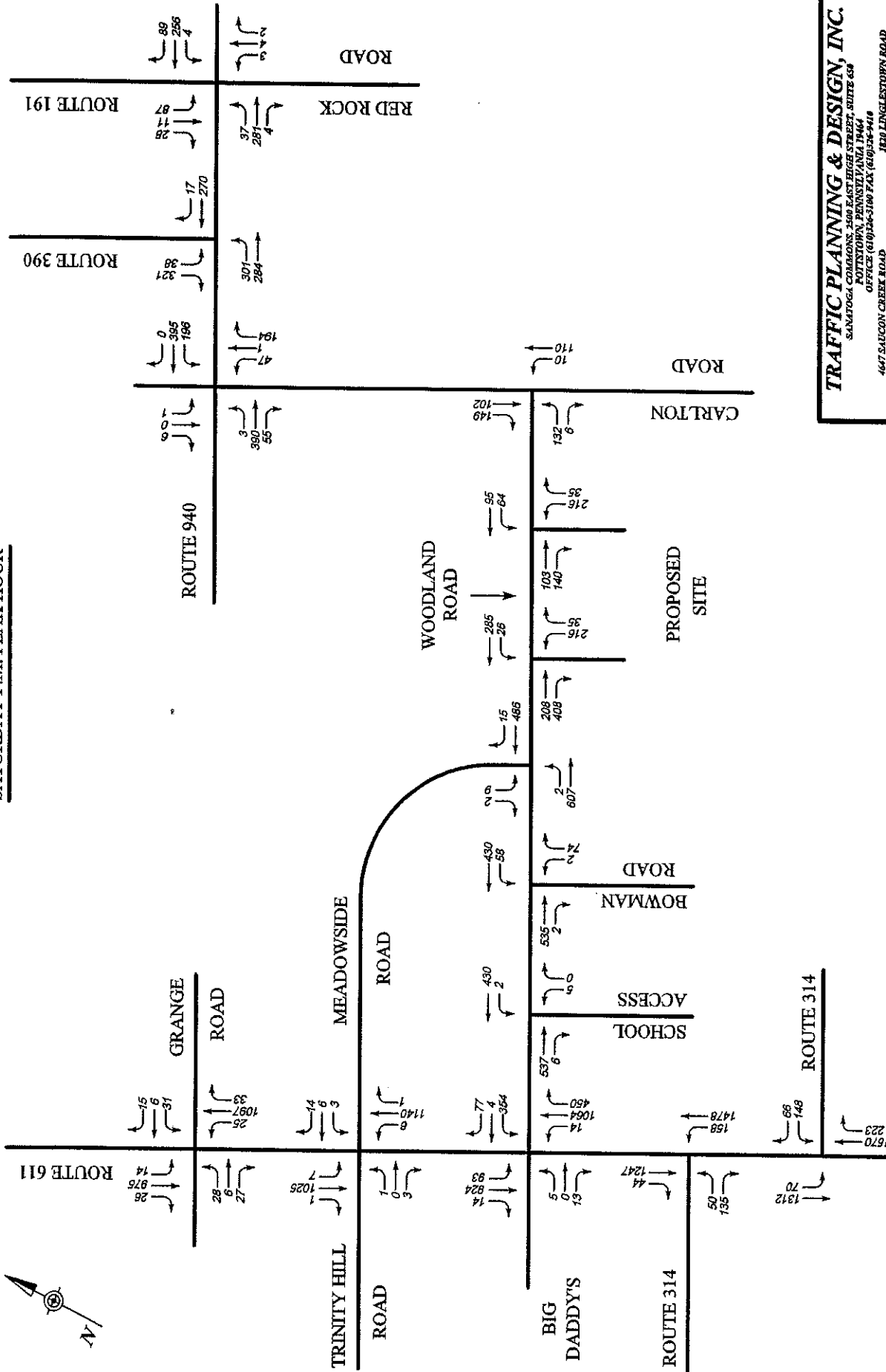

**TRAFFIC PLANNING & DESIGN, INC.**  
 300 EAST BROADWAY STREET, SUITE 658  
 SAMPOG COUNTY, PENNSYLVANIA 17054  
 OFFICE (610)334-3100 FAX (610)334-6410  
 4647 SAUCON CREEK ROAD  
 CENTER VALLEY, PA 16834  
 OFFICE (717)334-4259 OFFICE (717)334-4358 FAX (717)334-4400  
 E-MAIL: [TRAFFICEXPERTS@TRAFFICPD.COM](mailto:TRAFFICEXPERTS@TRAFFICPD.COM)

FIGURE 15

2007 PROJECTED CONDITIONS  
 SATURDAY P.M. PEAK HOUR  
 TRAFFIC VOLUMES

SCHEMATIC DRAWING: NOT TO SCALE

FRIDAY P.M. PEAK HOUR

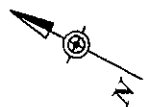
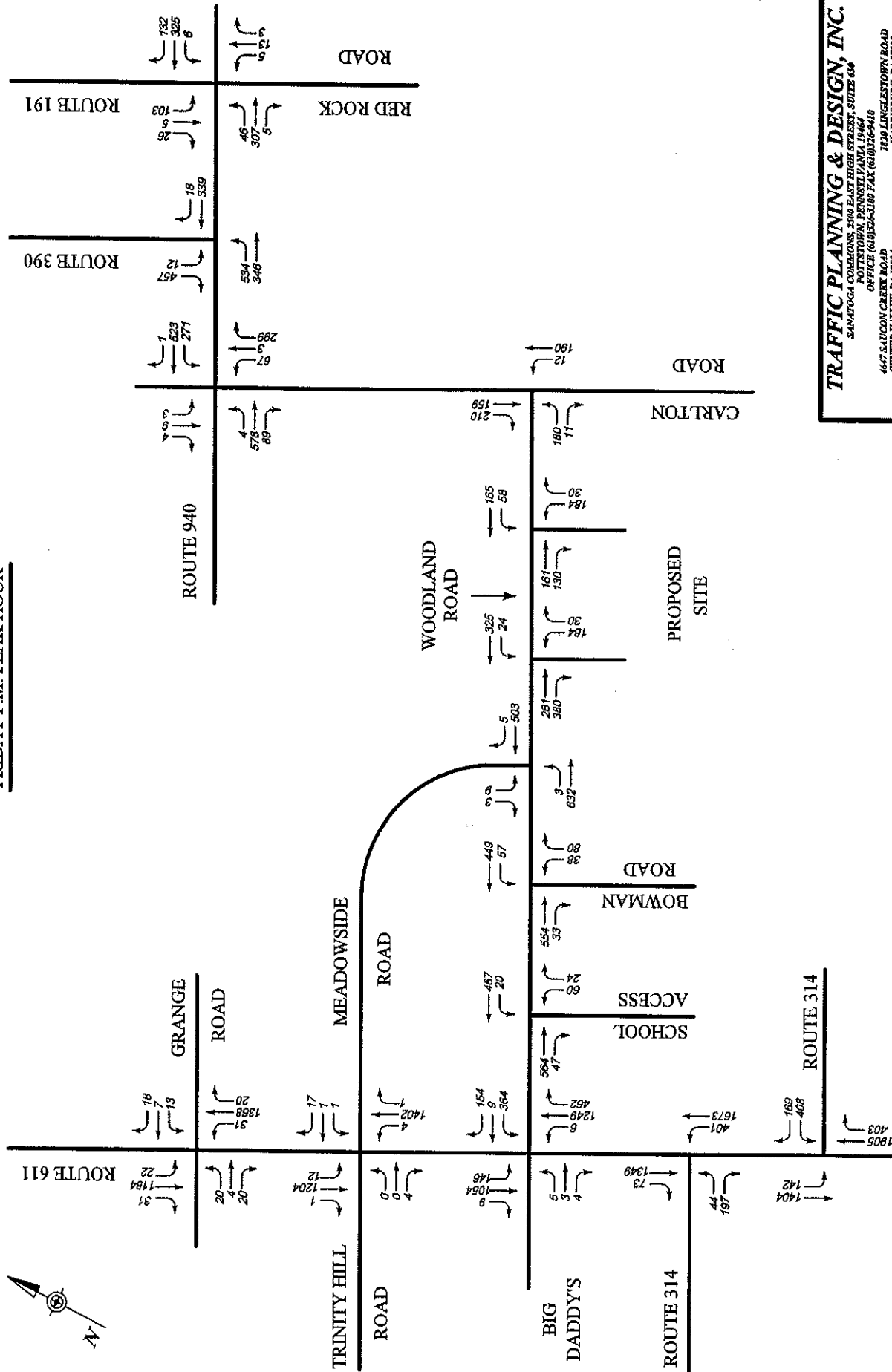

**TRAFFIC PLANNING & DESIGN, INC.**  
 SANATOGA COMMONS, 300 EAST HIGH STREET, SUITE 600  
 WASHINGTON, PENNSYLVANIA 15360  
 OFFICE (412) 326-1000 FAX (412) 326-1010  
 467 SAUCON CREEK ROAD  
 CENTER VALLEY PA 17110  
 OFFICE (610) 355-4242 FAX (610) 355-4250 OFFICE (717) 334-1800 FAX (717) 334-4400  
 E-MAIL TRAFFICEXPERTS@TRAFFICPD.COM

**FIGURE 16**  
 2017 PROJECTED CONDITIONS  
 FRIDAY P.M. PEAK HOUR  
 TRAFFIC VOLUMES

SCHEMATIC DRAWING: NOT TO SCALE

SATURDAY P.M. PEAK HOUR

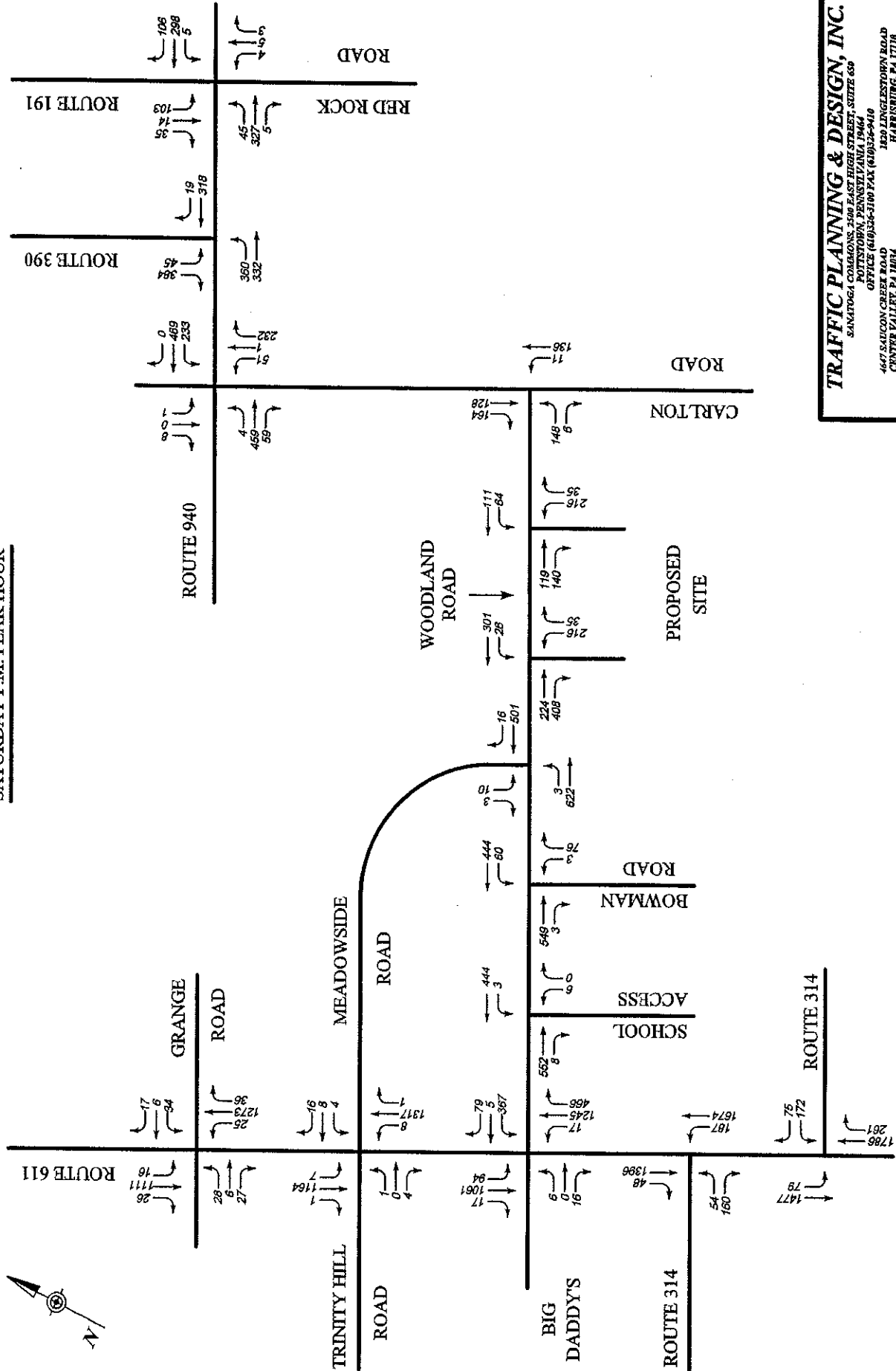

**TRAFFIC PLANNING & DESIGN, INC.**  
 SANITOGA CORPORS. 300 EAST HIGH STREET, SUITE 630  
 FARMERSVILLE, GA 30204  
 OFFICE (610)334-3100 FAX (610)334-9410  
 467 SAUCON CREEK ROAD  
 1820 LINGESTON ROAD  
 CENTER VALLEY PA 16834  
 HARRISBURG PA 17118  
 OFFICE (610)535-2432 FAX (610)535-2358 OFFICE (717)234-1500 FAX (717)234-4900  
 E-MAIL TRAFFICEXPERTS@TRAFFICPD.COM

**FIGURE 17**  
 2017 PROJECTED CONDITIONS  
 SATURDAY P.M. PEAK HOUR  
 TRAFFIC VOLUMES

SCHEMATIC DRAWING: NOT TO SCALE

FRIDAY P.M. PEAK HOUR

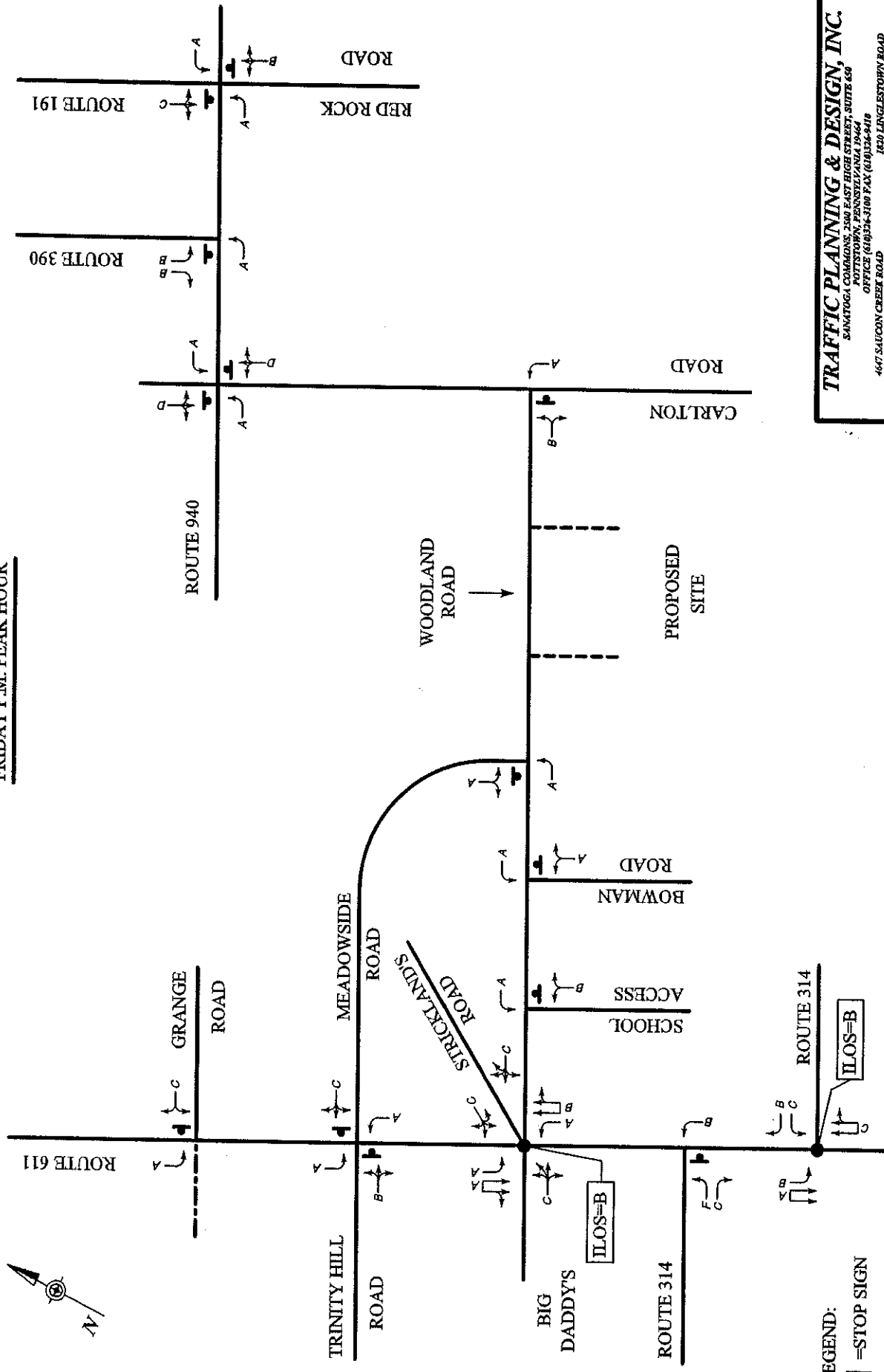

**TRAFFIC PLANNING & DESIGN, INC.**  
 SANATOGA COMMONS, 200 EAST HIGH STREET, SUITE 650  
 POTTSTOWN, PENNSYLVANIA 19464  
 OFFICE (610)334-3100 FAX (610)334-9418

467 SAUCON CREEK ROAD  
 CENTER VALLEY, PA 17244  
 OFFICE (717)234-1468 FAX (717)234-4090  
 E-MAIL: TRAFFICEXPERTS@TRAFFICPD.COM

**FIGURE 18**  
 2005 EXISTING CONDITIONS  
 FRIDAY P.M. PEAK HOUR  
 LEVELS OF SERVICE

**LEGEND:**  
 ● = STOP SIGN  
 ● = SIGNALIZED INTERSECTION  
 - - - - = PROPOSED GREEN SPRINGS DRIVEWAY  
 - - - - = PROPOSED SITE DRIVEWAY  
 SCHEMATIC DRAWING: NOT TO SCALE

SATURDAY P.M. PEAK HOUR

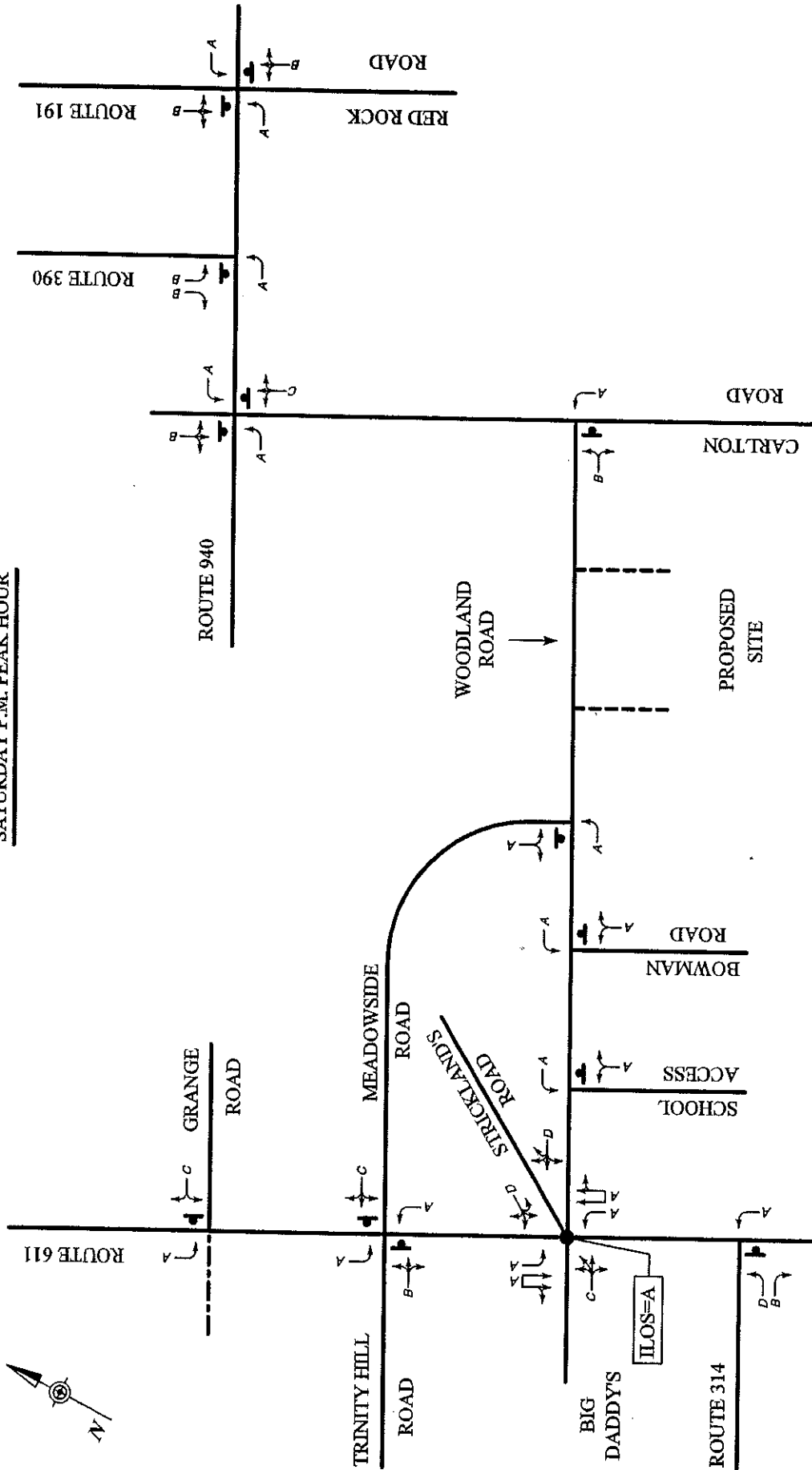

**LEGEND:**

- ◼ = STOP SIGN
- = SIGNALIZED INTERSECTION
- = PROPOSED GREEN SPRINGS DRIVEWAY
- - - = PROPOSED SITE DRIVEWAY

**SCHEMATIC DRAWING: NOT TO SCALE**

**TRAFFIC PLANNING & DESIGN, INC.**  
 3500 EAST HIGH STREET, SUITE 650  
 PITTSBURGH, PENNSYLVANIA 15201  
 OFFICE (724) 462-4242 FAX (724) 462-4249  
 467 SAUCON CREEK ROAD  
 RED BANK, PENNSYLVANIA 19880  
 OFFICE (610) 621-4242 FAX (610) 621-4239  
 E-MAIL: TRAFFICPERIN@TRAFFICPD.COM

**FIGURE 19**

2005 EXISTING CONDITIONS  
 SATURDAY P.M. PEAK HOUR  
 LEVELS OF SERVICE

FRIDAY P.M. PEAK HOUR

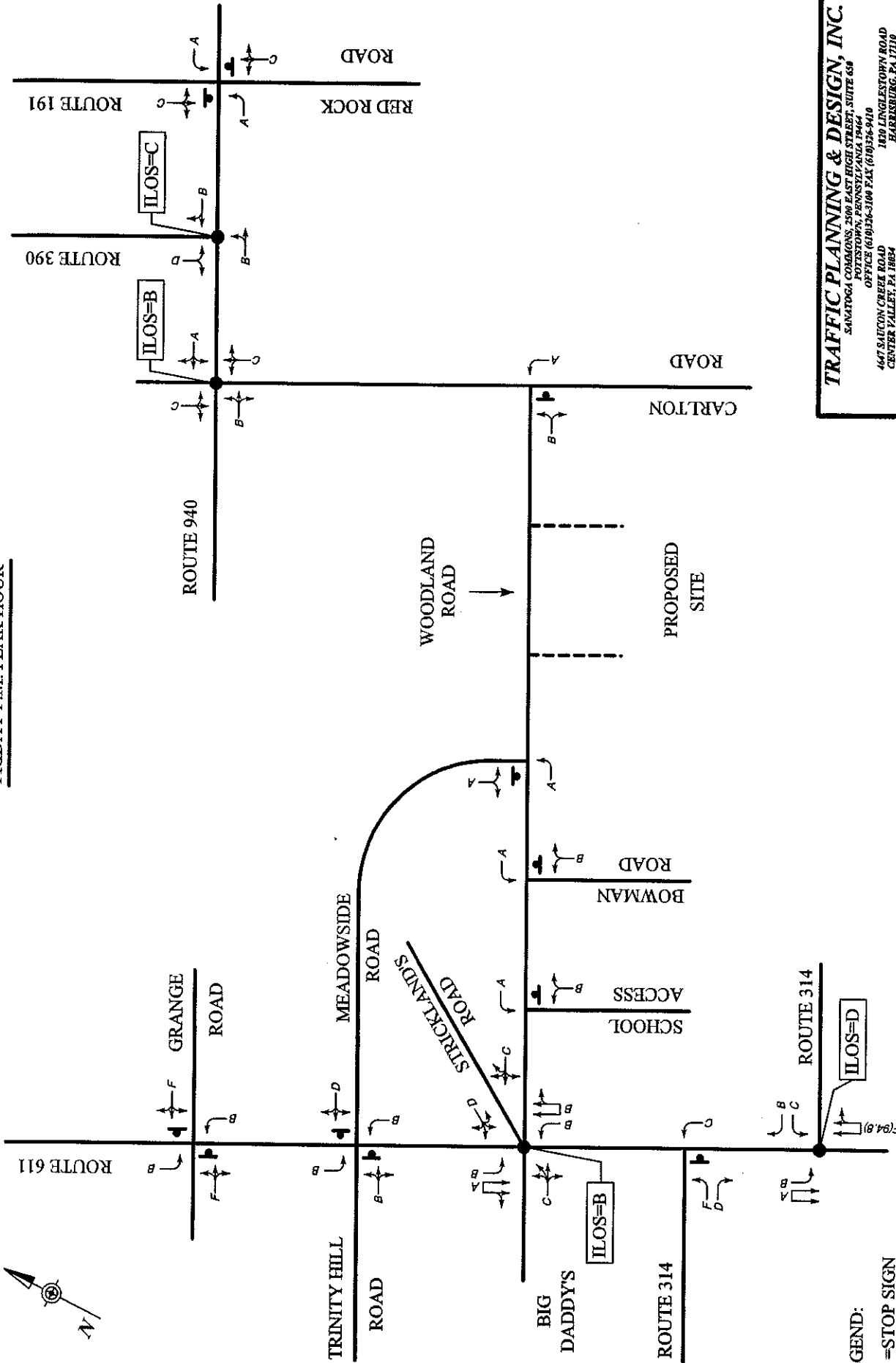

- LEGEND:**
- = STOP SIGN
  - = SIGNALIZED INTERSECTION
  - - - - = PROPOSED SITE DRIVEWAY
- SCHEMATIC DRAWING: NOT TO SCALE

**TRAFFIC PLANNING & DESIGN, INC.**  
 SANATOGA COLLEGE, 3400 N. STATE ST., SUITE 630  
 POTTSTOWN, PENNSYLVANIA 17422  
 OFFICE (610) 266-3100 FAX (610) 266-9410  
 4647 SAITON CREEK ROAD  
 CENTER VALLEY, PA 16834  
 OFFICE (717) 234-4230 OFFICE (717) 234-1539 FAX (717) 234-4400  
 E-MAIL: TRAFFICPEKTS@TRAFFICPD.COM

FIGURE 20  
 2007 BASE CONDITIONS  
 FRIDAY P.M. PEAK HOUR  
 LEVELS OF SERVICE

SATURDAY P.M. PEAK HOUR

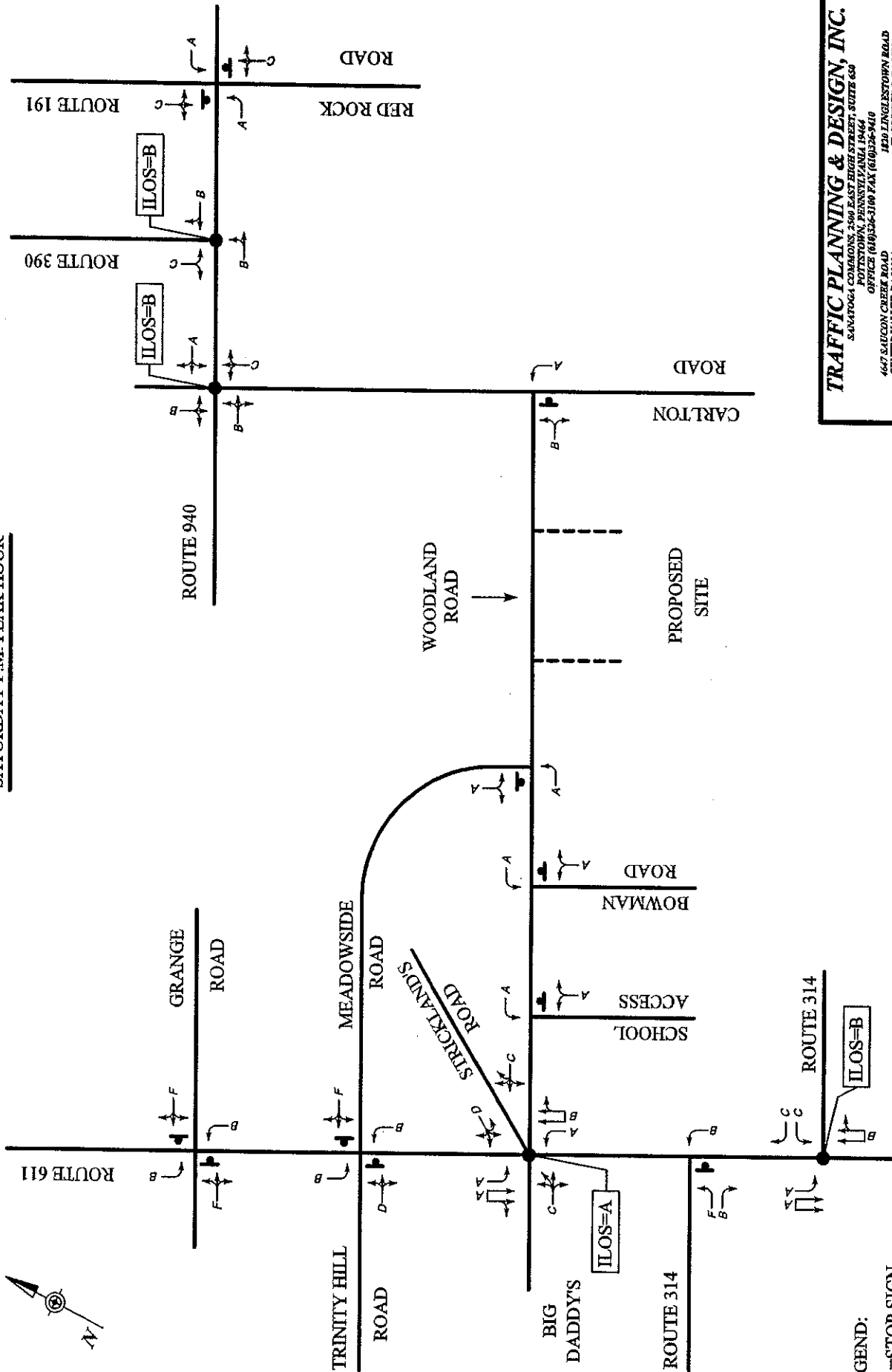

**LEGEND:**

- = STOP SIGN
- = SIGNALIZED INTERSECTION
- = PROPOSED SITE DRIVEWAY

SCHEMATIC DRAWING: NOT TO SCALE

**TRAFFIC PLANNING & DESIGN, INC.**  
 SANATOGA COMMONS, 2500 EAST HIGH STREET, SUITE 630  
 PITTSBURGH, PENNSYLVANIA 15146  
 OFFICE (412) 241-1100 FAX (412) 241-1100  
 467 SAUCON CREEK ROAD  
 100 BRIDGESTOWN ROAD  
 CENTER VALLEY, PA 16830  
 OFFICE (814) 424-2424 FAX (814) 424-2424  
 E-MAIL: TRAFFICEXPERTS@TRAFFICPA.COM

**FIGURE 21**

2007 BASE CONDITIONS  
 SATURDAY P.M. PEAK HOUR  
 LEVELS OF SERVICE



FRIDAY P.M. PEAK HOUR

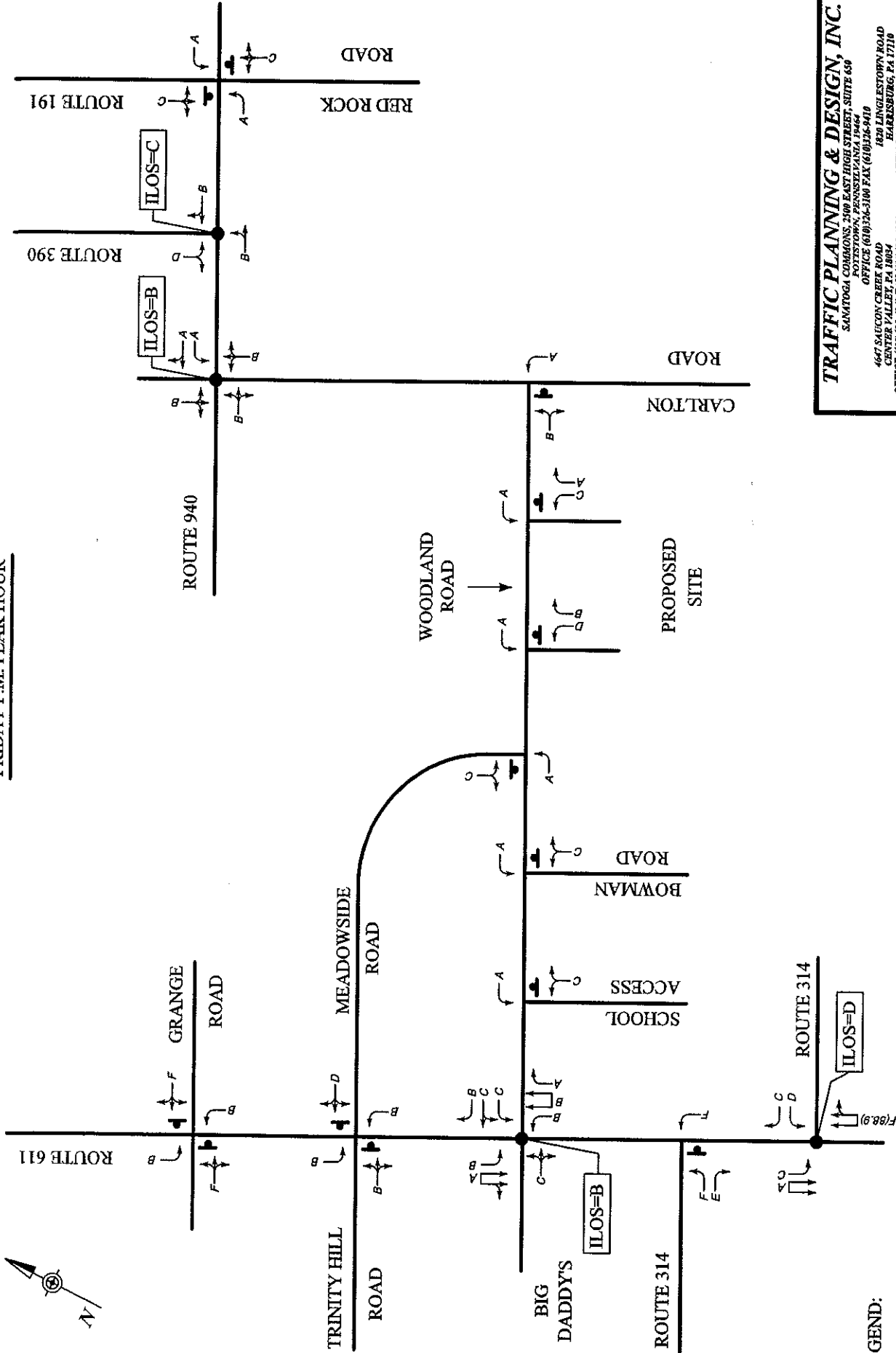

LEGEND:

● = STOP SIGN

○ = SIGNALIZED INTERSECTION

SCHEMATIC DRAWING: NOT TO SCALE

**TRAFFIC PLANNING & DESIGN, INC.**

SANATOGA COMMONS, 3100 EAST HIGH STREET, SUITE 609  
 POTTSVILLE, PENNSYLVANIA 17854  
 OFFICE (610)326-3100 FAX (610)326-9410  
 4647 SAUCON CREEK ROAD  
 CENTER VALLEY, PA 18834  
 OFFICE (610)635-4242 FAX (610)635-4250  
 1820 LINGLESTOWN ROAD  
 HARRISBURG, PA 17110  
 OFFICE (717)334-1488 FAX (717)334-4498  
 E-MAIL: TRAFFICEXPERTS@TRAFFICPD.COM

FIGURE 22

2007 PROJECTED CONDITIONS - WITH IMPROVEMENTS  
 FRIDAY P.M. PEAK HOUR  
 LEVELS OF SERVICE

SATURDAY P.M. PEAK HOUR

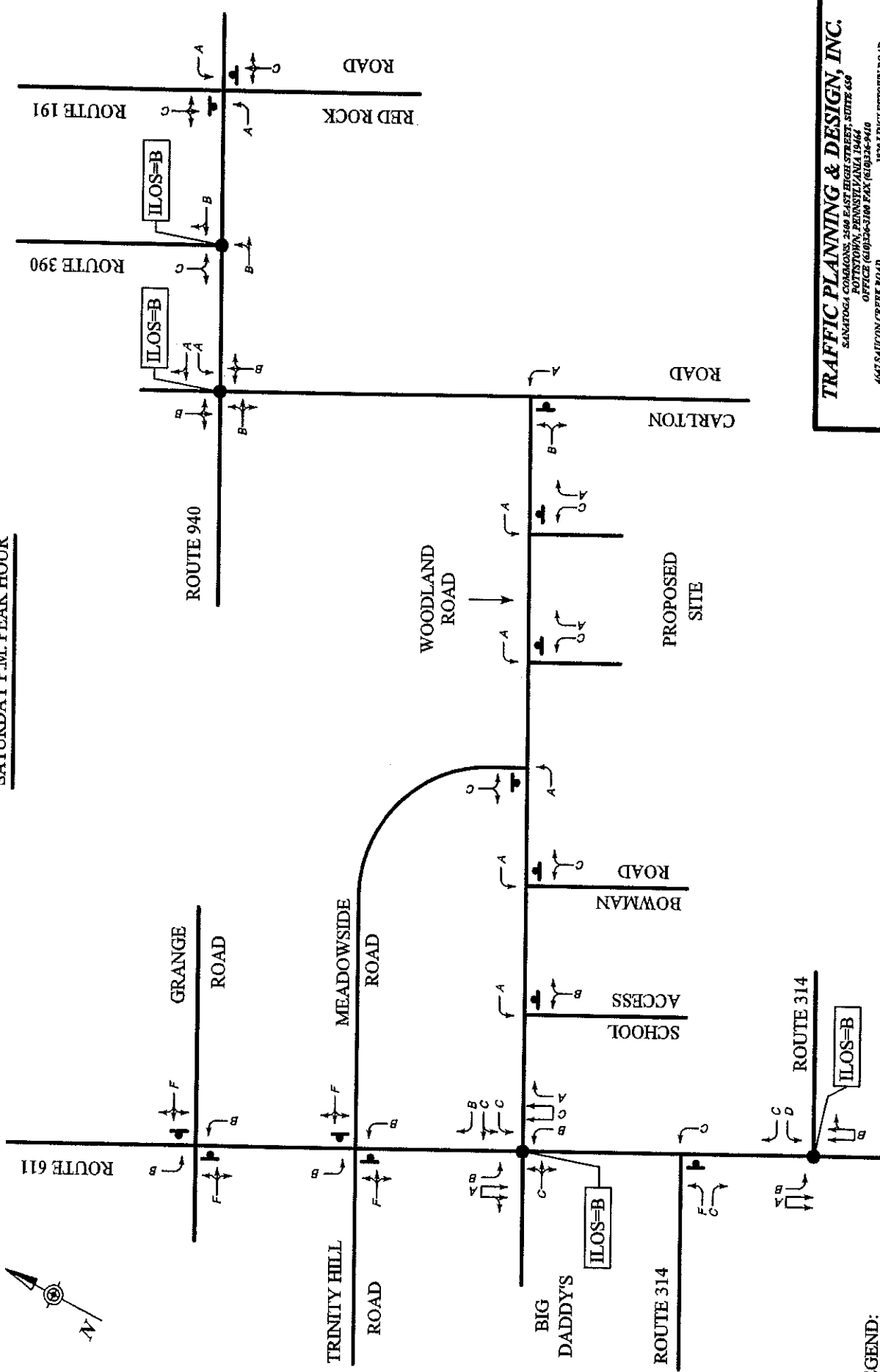

LEGEND:

● = STOP SIGN

● = SIGNALIZED INTERSECTION

SCHEMATIC DRAWING: NOT TO SCALE

**TRAFFIC PLANNING & DESIGN, INC.**  
 3400 W. 10TH STREET, SUITE 200  
 DENVER, COLORADO 80202  
 OFFICE: (303) 733-1111 FAX: (303) 733-1112  
 120 LINGLESTOWN ROAD  
 HARRISBURG, PA 17110  
 OFFICE: (717) 234-1600 FAX: (717) 234-4490  
 E-MAIL: TRAFFICEXPERTS@TRAFFICPD.COM

FIGURE 23

2007 PROJECTED CONDITIONS - WITH IMPROVEMENTS  
 SATURDAY P.M. PEAK HOUR  
 LEVELS OF SERVICE

FRIDAY P.M. PEAK HOUR

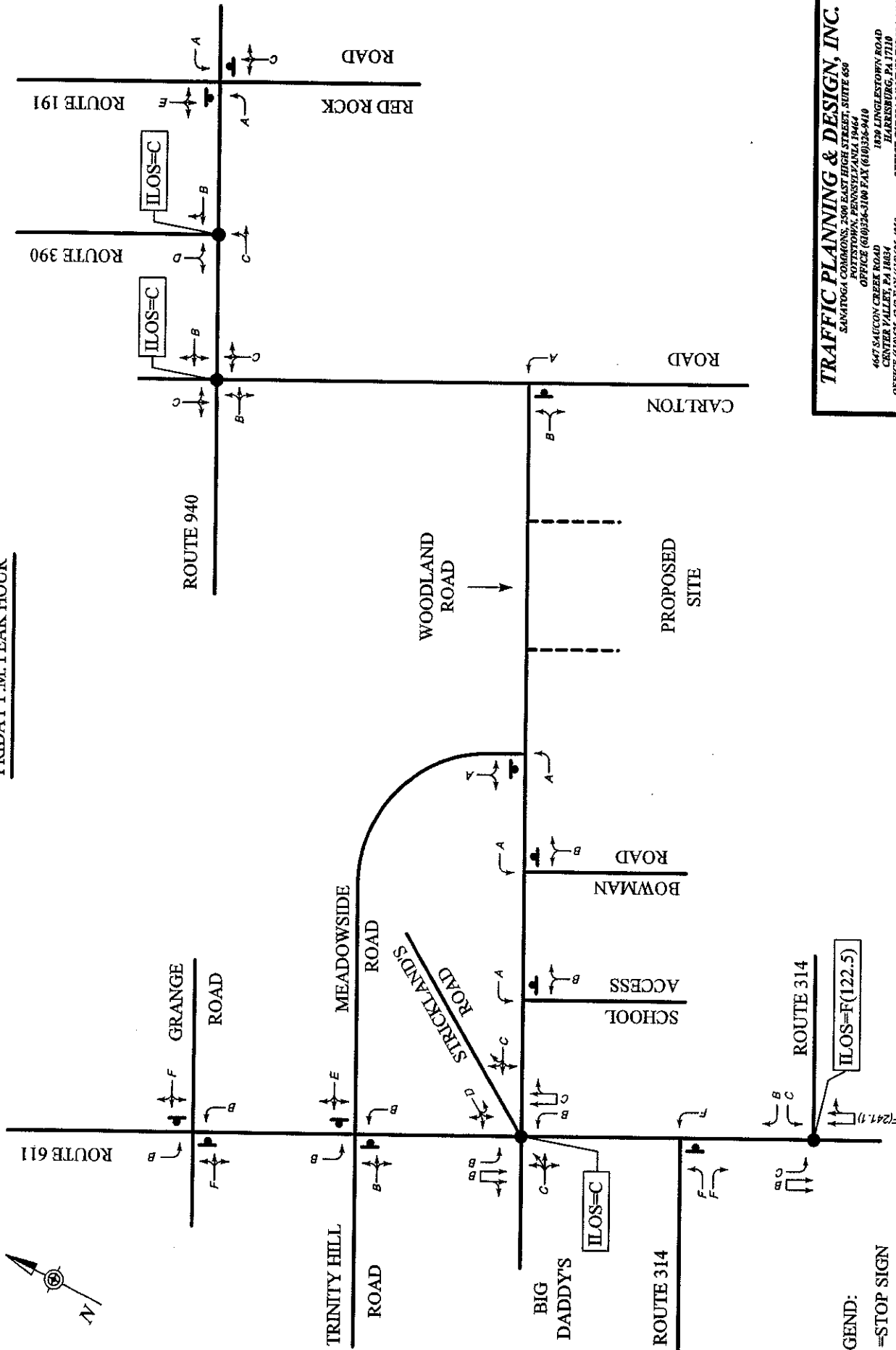

**TRAFFIC PLANNING & DESIGN, INC.**  
 SAMATOGA COMMONS, 2500 EAST HIGH STREET, SUITE 609  
 POTTSTOWN, PENNSYLVANIA 19464  
 OFFICE (610)326-3100 FAX (610)326-9410  
 4647 SAUCON CREEK ROAD  
 CENTER VALLEY, PA 16834  
 OFFICE (610)953-4222 FAX (610)953-4259  
 1876 LINGESTOWN ROAD  
 HARRISBURG, PA 17110  
 OFFICE (717)334-1499 FAX (717)334-4499  
 E-MAIL TRAFFICEXPERTS@TRAFFICPD.COM

FIGURE 24

2017 BASE CONDITIONS  
 FRIDAY P.M. PEAK HOUR  
 LEVELS OF SERVICE

- LEGEND:
- = STOP SIGN
  - = SIGNALIZED INTERSECTION
  - - - = PROPOSED SITE DRIVEWAY
- SCHEMATIC DRAWING: NOT TO SCALE

SATURDAY P.M. PEAK HOUR

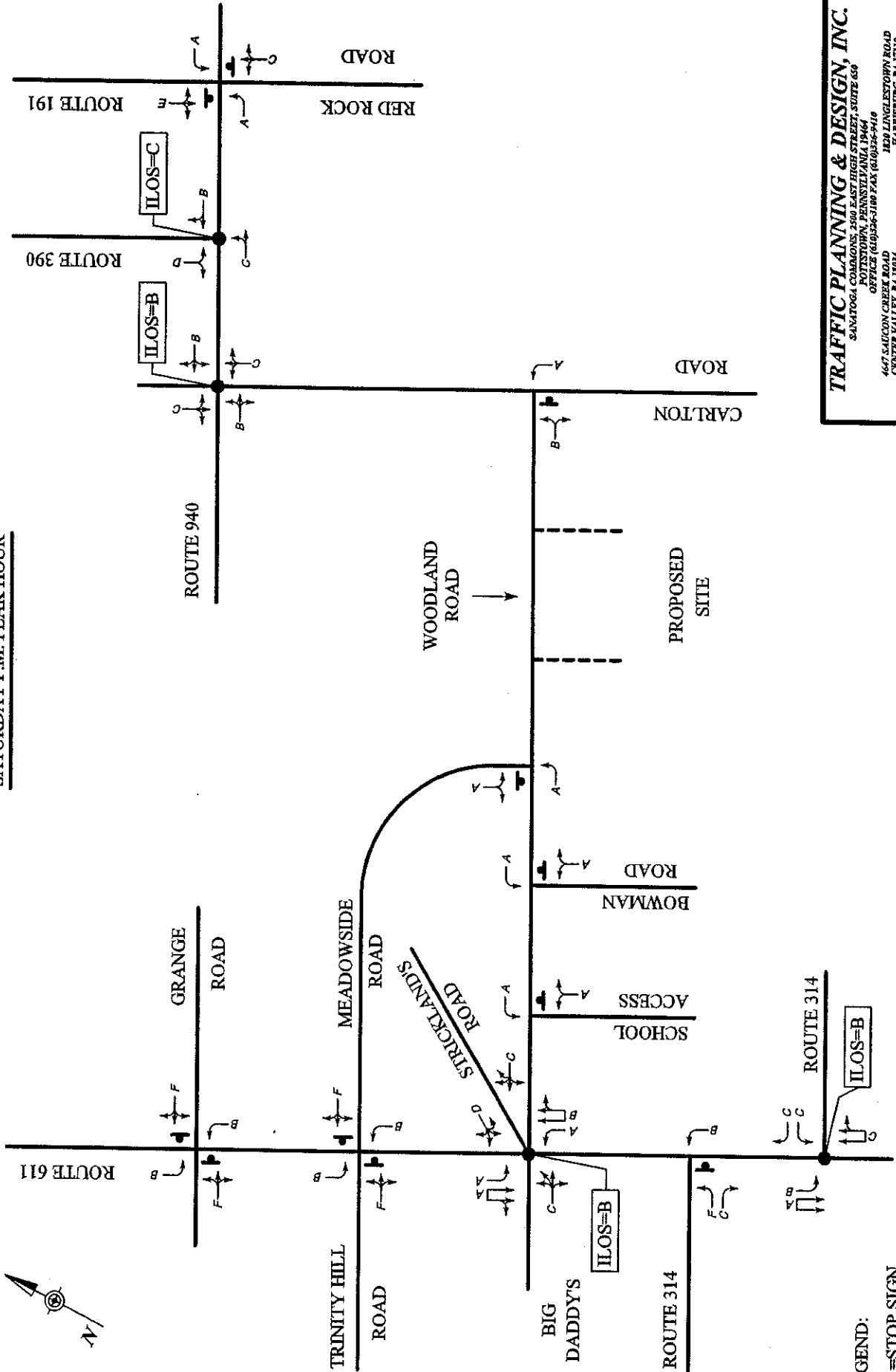

- LEGEND:
- = STOP SIGN
  - = SIGNALIZED INTERSECTION
  - = PROPOSED SITE DRIVEWAY
- SCHEMATIC DRAWING: NOT TO SCALE

**TRAFFIC PLANNING & DESIGN, INC.**  
 354 MITCHELL AVENUE, SUITE 200  
 HARRISBURG, PA 17110  
 OFFICE (717) 334-4138 FAX (717) 334-4099  
 E-MAIL: TRAFFICEXPERTS@TRAFFICPD.COM

467 SAUCON CREEK ROAD  
 HARRISBURG, PA 17110  
 OFFICE (717) 334-4138 FAX (717) 334-4099  
 E-MAIL: TRAFFICEXPERTS@TRAFFICPD.COM

120 LINGLESTOWN ROAD  
 HARRISBURG, PA 17110  
 OFFICE (717) 334-4138 FAX (717) 334-4099  
 E-MAIL: TRAFFICEXPERTS@TRAFFICPD.COM

354 MITCHELL AVENUE, SUITE 200  
 HARRISBURG, PA 17110  
 OFFICE (717) 334-4138 FAX (717) 334-4099  
 E-MAIL: TRAFFICEXPERTS@TRAFFICPD.COM

**FIGURE 25**

2017 BASE CONDITIONS  
 SATURDAY P.M. PEAK HOUR  
 LEVELS OF SERVICE

FRIDAY P.M. PEAK HOUR

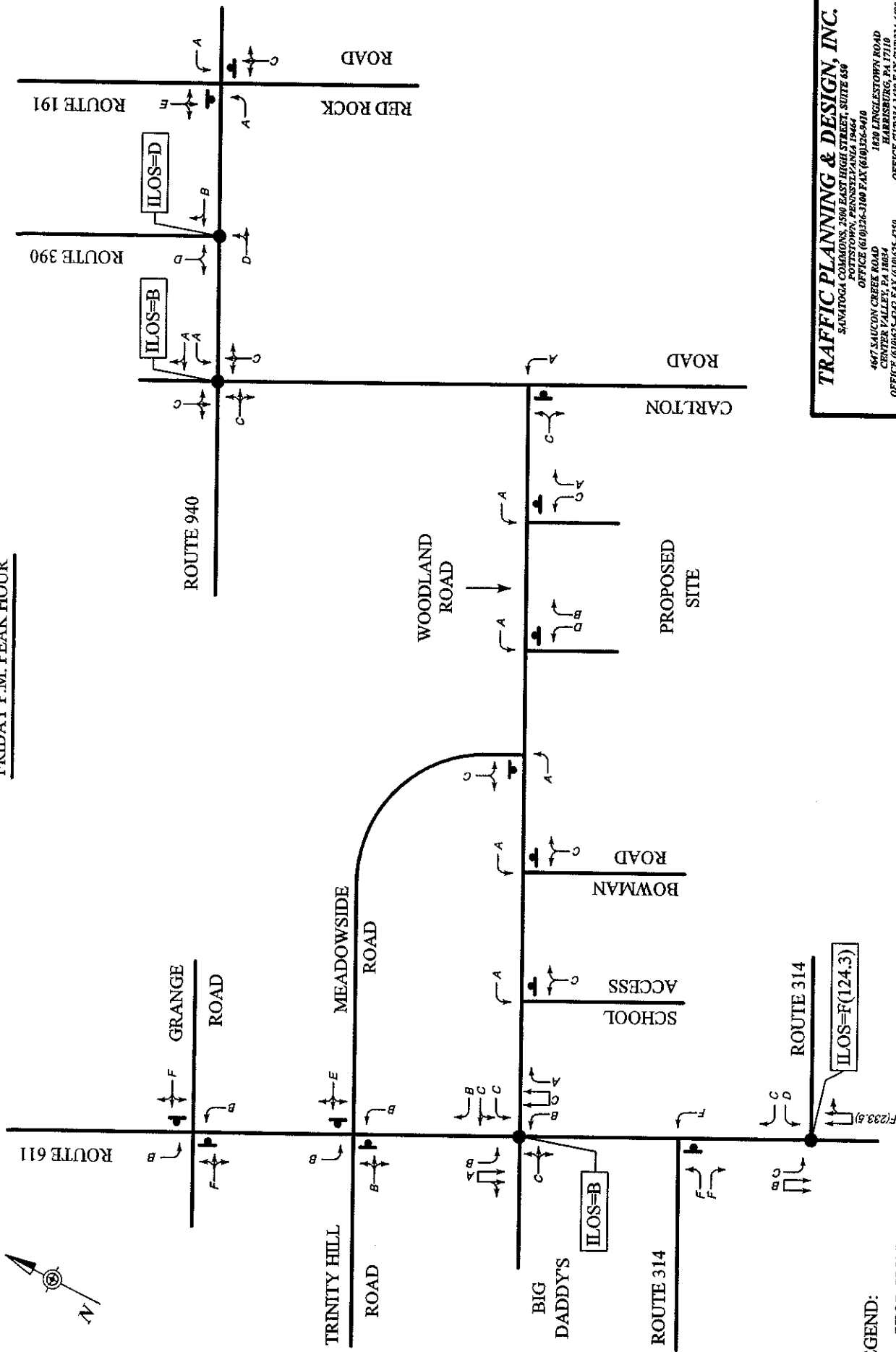

- LEGEND:
- = STOP SIGN
  - = SIGNALIZED INTERSECTION
- SCHEMATIC DRAWING: NOT TO SCALE

**TRAFFIC PLANNING & DESIGN, INC.**  
 SAMATOGA COMMONS, 2500 EAST HIGH STREET, SUITE 630  
 POTTSTOWN, PENNSYLVANIA 19464  
 OFFICE (610)326-3100 FAX (610)326-9410  
 4667 SAUCON CREEK ROAD  
 CENTER VALLEY, PA 16844  
 OFFICE (717)234-4242 FAX (717)234-4350  
 HARRISBURG, PA 17110  
 OFFICE (610)823-4242 FAX (610)823-4350  
 E-MAIL: TRAFFICEXPERTS@TRAFFICPD.COM

FIGURE 26

2017 PROJECTED CONDITIONS - WITH IMPROVEMENTS  
 FRIDAY P.M. PEAK HOUR  
 LEVELS OF SERVICE

SATURDAY P.M. PEAK HOUR

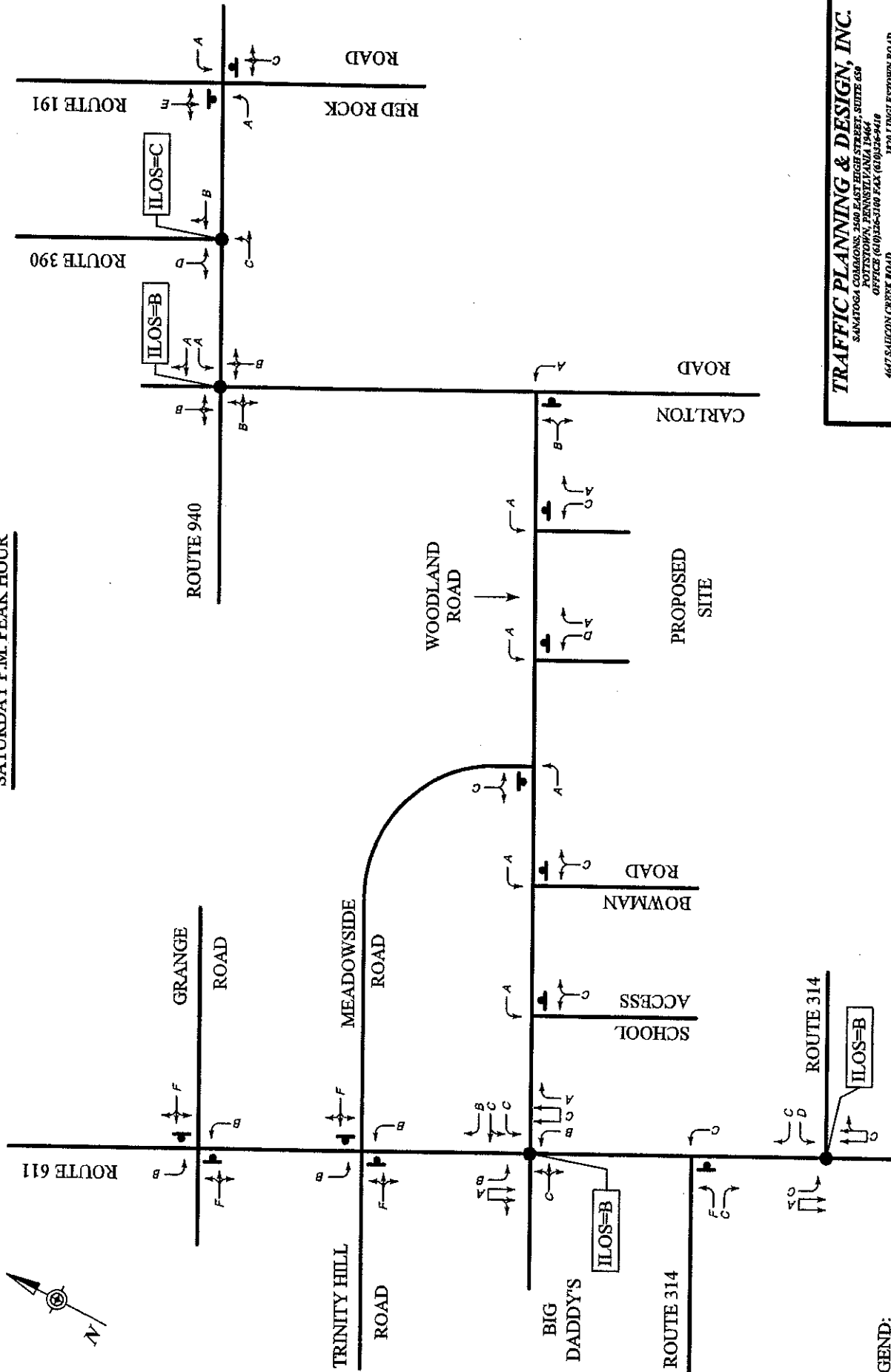

LEGEND:

● = STOP SIGN

○ = SIGNALIZED INTERSECTION

SCHEMATIC DRAWING: NOT TO SCALE

**TRAFFIC PLANNING & DESIGN, INC.**

3404066 / 1000 N. MARKET STREET, SUITE 250  
 NOTISTOWN, PENNSYLVANIA 17055  
 OFFICE (610)324-3100 FAX (610)324-2418  
 4607 SALICON CREEK ROAD  
 CENTER VALLEY, PA 17018  
 OFFICE (610)635-0202 FAX (610)635-4250  
 E-MAIL: TRAFFICPEKTS@TRAFFICPD.COM

FIGURE 27

2017 PROJECTED CONDITIONS - WITH IMPROVEMENTS  
 SATURDAY P.M. PEAK HOUR  
 LEVELS OF SERVICE

***APPENDIX A***  
***STUDY AREA PHOTOGRAPHS***



**Direction / Road:** Northbound Route 611  
**Approach / Departure:** Approaching Route 314

---



**Direction / Road:** Southbound Route 611  
**Approach / Departure:** Approaching Route 314

---





**Direction / Road:** Westbound Route 314  
**Approach / Departure:** Approaching Route 611

---



**Direction / Road:** Northbound Route 611  
**Approach / Departure:** Approaching Route 314

---



**Direction / Road:** Southbound Route 611  
**Approach / Departure:** Approaching Route 314

---

---



**Direction / Road:** Eastbound Route 314

**Approach / Departure:** Approaching Route 611

---

---



**Direction / Road:** Northbound Route 611  
**Approach / Departure:** Approaching Woodland Road

---



**Direction / Road:** Southbound Route 611  
**Approach / Departure:** Approaching Woodland Road

---



**Direction / Road:** Westbound Woodland Road  
**Approach / Departure:** Approaching Route 611

---



**Direction / Road:** Westbound Strickland's Road  
**Approach / Departure:** Approach Route 611

---



**Direction / Road:** Eastbound Big daddy's Driveway  
**Approach / Departure:** Approaching Route 611

---

---



**Direction / Road:** Northbound Route 611

**Approach / Departure:** Approaching Meadowside Road/Trinity Hill Road

---



**Direction / Road:** Southbound Route 611

**Approach / Departure:** Approaching Meadowside Road/Trinity Hill Road

---



**Direction / Road:** Westbound Meadowside Road  
**Approach / Departure:** Approaching Route 611

---



**Direction / Road:** Eastbound Trinity Hill Road  
**Approach / Departure:** Approaching Route 611

---





**Direction / Road:** Northbound Route 611  
**Approach / Departure:** Approaching Grange Road

---



**Direction / Road:** Southbound Route 611  
**Approach / Departure:** Approaching Grange Road

---



**Direction / Road:** Westbound Grange Road  
**Approach / Departure:** Approaching Route 611

---

---



**Direction / Road:** Eastbound Woodland Road  
**Approach / Departure:** Approaching School Driveway

---



**Direction / Road:** Westbound Woodland Road  
**Approach / Departure:** Approaching School Driveway

---



**Direction / Road:** Northbound School Driveway  
**Approach / Departure:** Approaching Woodland Road

---

---



**Direction / Road:** Eastbound Woodland Road  
**Approach / Departure:** Approaching Bowman Road

---



**Direction / Road:** Westbound Bowman Road  
**Approach / Departure:** Approaching Woodland Road

---



**Direction / Road:** Northbound Bowman Road  
**Approach / Departure:** Approaching Woodland Road

---

---



**Direction / Road:** Eastbound Woodland Road  
**Approach / Departure:** Approaching Meadowside Road

---



**Direction / Road:** Westbound Woodland Road  
**Approach / Departure:** Approaching Meadowside Road

---



**Direction / Road:** Southbound Meadowsided Road  
**Approach / Departure:** Approaching Woodland Road

---

---





**Direction / Road:** Northbound Carlton Road  
**Approach / Departure:** Approaching Woodland Road

---



**Direction / Road:** Southbound Carlton Road  
**Approach / Departure:** Approaching Woodland Road

---



**Direction / Road:** Eastbound Woodland Road

**Approach / Departure:** Approaching Carlton Road

---

---



**Direction / Road:** Northbound Carlton Road

**Approach / Departure:** Approaching Route 940

---



**Direction / Road:** Southbound Caesar's Resort driveway

**Approach / Departure:** Approaching Route 940

---



**Direction / Road:** Eastbound Route 940

**Approach / Departure:** Approaching Carlton Road/Caesar's Resort driveway

---



**Direction / Road:** Westbound Route 940

**Approach / Departure:** Approaching Carlton Road/Caesar's Resort driveway

---



**Direction / Road:** Eastbound Route 940  
**Approach / Departure:** Approaching Route 390

---



**Direction / Road:** Westbound Route 940  
**Approach / Departure:** Approaching Route 390

---



**Direction / Road:** Southbound Route 390  
**Approach / Departure:** Approaching Route 940

---

---



**Direction / Road:** Northbound Red rock Road  
**Approach / Departure:** Approaching Route 940

---



**Direction / Road:** Southbound Route 191  
**Approach / Departure:** Approaching Route 940

---



**Direction / Road:** Eastbound Route 940

**Approach / Departure:** Approaching Route 191/Red Rock Road

---



**Direction / Road:** Westbound route 940

**Approach / Departure:** Approaching Route 191/Red Rock Road

---



***APPENDIX B***  
***MANUAL TRAFFIC COUNT PRINTOUTS &***  
***ITMS DATA SHEETS***

***MANUAL TRAFFIC COUNT PRINTOUTS***

Counter: 28  
 Counted By: S. Gault  
 Weather: clear  
 As: PM314611

File Name : PM314611  
 Site Code : 00000000  
 Start Date : 5/20/2005  
 Page No : 1

Groups Printed- Unshifted

Start Time	Route 611 Southbound					Route 314 Westbound					Route 611 Northbound					Eastbound					Exclu. Total	Inclu. Total	Int. Total	
	Left	Thru	Right	Truck	App. Total	Left	Thru	Right	Truck	App. Total	Left	Thru	Right	Truck	App. Total	Left	Thru	Right	Truck	App. Total				
Factor	1.0	1.0	1.0	1.0		1.0	1.0	1.0	1.0		1.0	1.0	1.0	1.0		1.0	1.0	1.0	1.0					
04:00 PM	17	154	0	3	171	76	0	22	0	98	0	172	55	7	227	0	0	0	0	0				
04:15 PM	19	169	0	7	188	61	0	18	1	79	1	224	67	22	292	0	0	0	0	0	10	496	506	
04:30 PM	25	209	0	1	234	74	0	40	0	114	1	239	58	9	298	0	0	0	0	0	30	559	589	
04:45 PM	29	172	0	3	201	71	0	28	0	99	1	232	55	3	288	0	0	0	0	0	10	646	656	
Total	90	704	0	14	794	282	0	108	1	390	3	867	235	41	1105	0	0	0	0	0	6	588	594	
05:00 PM	17	135	0	0	152	43	0	22	0	65	3	231	58	2	292	0	0	0	0	0	56	2289	2345	
05:15 PM	10	124	0	2	134	58	0	32	0	90	1	248	51	2	300	0	0	0	0	0	2	509	511	
05:30 PM	17	136	0	3	153	51	0	18	3	69	1	242	54	3	297	0	0	0	0	0	4	524	528	
05:45 PM	17	128	0	3	145	37	0	12	1	49	1	231	45	6	277	0	0	0	0	0	9	519	528	
Total	61	523	0	8	584	189	0	84	4	273	6	952	208	13	1166	0	0	0	0	0	10	471	481	
06:00 PM	21	133	0	2	154	40	0	10	0	50	0	224	68	4	292	0	0	0	0	0	25	2023	2048	
06:15 PM	15	128	0	1	143	51	0	12	1	63	0	187	68	4	255	0	0	0	0	0	6	496	502	
06:30 PM	18	129	0	2	147	37	0	4	0	41	0	178	60	3	238	0	0	0	0	0	6	461	467	
06:45 PM	21	120	0	4	141	30	0	7	0	37	1	177	55	5	233	0	0	0	0	0	5	426	431	
Total	75	510	0	9	585	158	0	33	1	191	1	766	251	16	1018	0	0	0	0	0	9	411	420	
07:00 PM	11	92	0	3	103	14	0	11	0	25	0	146	38	2	184	0	0	0	0	0	26	1794	1820	
07:15 PM	19	103	0	7	122	35	0	4	0	39	1	164	32	5	197	0	0	0	0	0	5	312	317	
07:30 PM	11	93	0	0	104	26	0	12	0	38	0	142	29	2	171	0	0	0	0	0	12	358	370	
07:45 PM	17	82	0	2	99	20	0	9	1	29	2	158	38	4	198	0	0	0	0	0	2	313	315	
Total	58	370	0	12	428	95	0	36	1	131	3	610	137	13	750	0	0	0	0	0	7	326	333	
Grand Total	284	2107	0	43	2391	724	0	261	7	985	13	3195	831	83	4039	0	0	0	0	0	26	1309	1335	
Apprch %	11.9	88.1	0			73.5	0	26.5			0.3	79.1	20.6			0	0	0			133	7415	7548	
Total %	3.8	28.4	0		32.2	9.8	0	3.5		13.3	0.2	43.1	11.2		54.5	0	0	0	0		1.8	98.2		

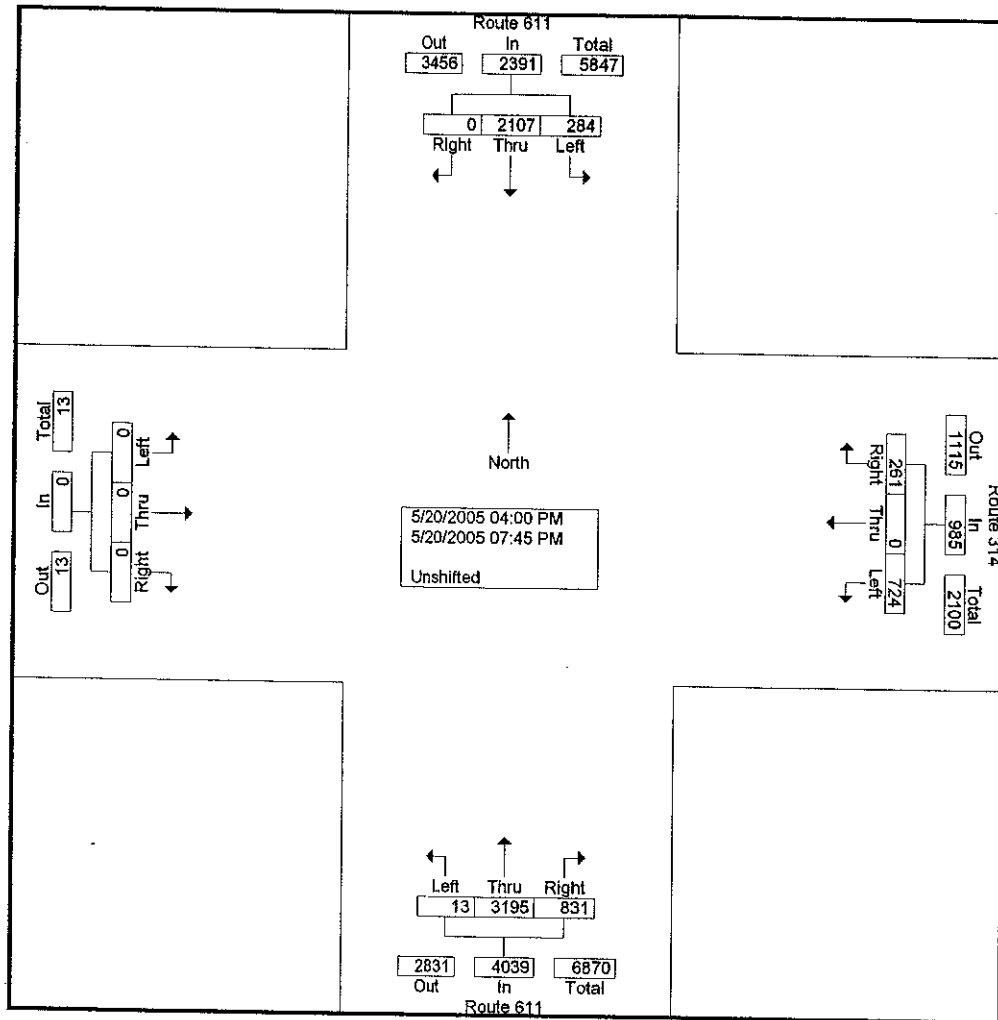

Start Time	Route 611 Southbound				Route 314 Westbound				Route 611 Northbound				Route 314 Eastbound				Int. Total
	Left	Thru	Right	App. Total	Left	Thru	Right	App. Total	Left	Thru	Right	App. Total	Left	Thru	Right	App. Total	
Peak Hour Analysis from 04:00 PM to 07:45 PM - Peak 1 of 1																	
Peak Hour for Entire Intersection Begins at 04:15 PM																	
04:15 PM	19	169	0	188	61	0	18	79	1	224	67	292	0	0	0	0	559
04:30 PM	25	209	0	234	74	0	40	114	1	239	58	298	0	0	0	0	646
04:45 PM	29	172	0	201	71	0	28	99	1	232	55	288	0	0	0	0	588
05:00 PM	17	135	0	152	43	0	22	65	3	231	58	292	0	0	0	0	509
Total Volume	90	685	0	775	249	0	108	357	6	926	238	1170	0	0	0	0	2302
% App. Total	11.6	88.4	0		69.7	0	30.3		0.5	79.1	20.3		0	0	0		
PHIF	.776	.819	.000	.828	.841	.000	.675	.783	.500	.969	.888	.982	.000	.000	.000	.000	.891

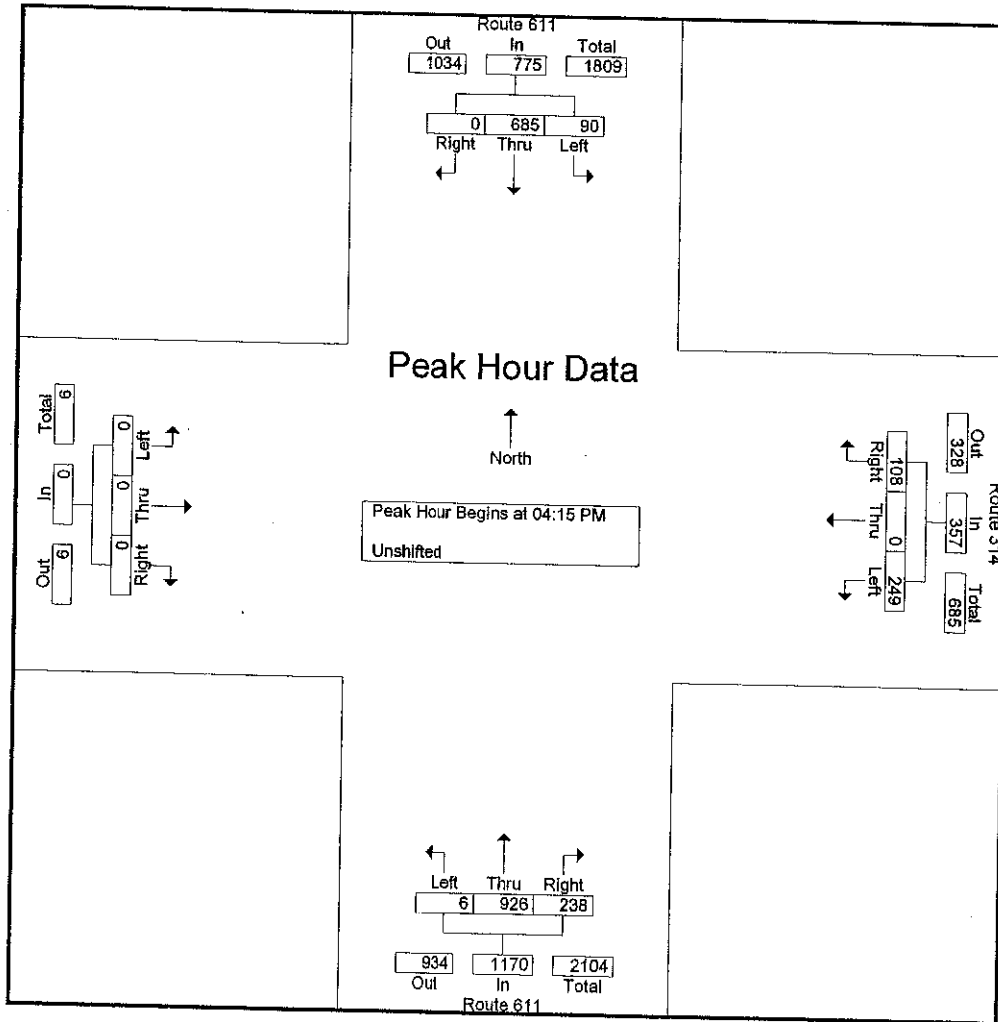

Counter: 3  
 Counted By: D. Bitterlich  
 Weather: clear  
 As: PM611314

File Name : PM611314  
 Site Code : 00000000  
 Start Date : 5/20/2005  
 Page No : 1

Groups Printed- Unshifted

Start Time	Route 611 Southbound					Driveway Westbound					Route 611 Northbound					Route 314 Eastbound					Exclu. Total	Inclu. Total	Int. Total
	Left	Thru	Right	Truck	App. Total	Left	Thru	Right	Truck	App. Total	Left	Thru	Right	Truck	App. Total	Left	Thru	Right	Truck	App. Total			
Factor	1.0	1.0	1.0	1.0		1.0	1.0	1.0	1.0		1.0	1.0	1.0	1.0		1.0	1.0	1.0	1.0				
04:00 PM	0	137	10	2	147	0	0	0	0	0	47	162	0	9	209	2	0	30	4	32	15	388	403
04:15 PM	2	163	3	7	168	0	0	0	0	0	59	168	0	7	227	5	1	30	3	36	17	431	448
04:30 PM	1	198	4	7	203	0	0	1	0	1	81	197	0	3	278	2	0	32	0	34	10	516	526
04:45 PM	1	150	9	7	160	0	0	0	0	0	61	191	0	3	252	5	0	48	2	53	12	465	477
Total	4	648	26	23	678	0	0	1	0	1	248	718	0	22	966	14	1	140	9	155	54	1800	1854
05:00 PM	0	111	6	4	117	1	0	0	0	1	67	196	0	4	263	0	0	34	1	34	9	415	424
05:15 PM	2	124	12	1	138	0	0	0	0	0	78	207	0	3	285	2	0	18	2	20	6	443	449
05:30 PM	1	125	5	4	131	0	0	0	0	0	60	202	0	3	262	3	0	31	1	34	8	427	435
05:45 PM	1	121	5	2	127	0	0	0	0	0	52	191	0	6	243	3	0	20	1	23	9	393	402
Total	4	481	28	11	513	1	0	0	0	1	257	796	0	16	1053	8	0	103	5	111	32	1678	1710
06:00 PM	1	121	6	3	128	0	0	0	0	0	38	179	0	2	217	10	0	27	0	37	5	382	387
06:15 PM	0	122	4	4	126	0	0	0	0	0	28	191	0	4	219	9	0	26	0	35	8	380	388
06:30 PM	0	117	5	3	122	0	0	0	0	0	32	161	0	4	193	4	0	31	0	35	7	350	357
06:45 PM	0	109	11	4	120	0	0	0	0	0	24	146	0	2	170	2	0	20	1	22	7	312	319
Total	1	469	26	14	496	0	0	0	0	0	122	677	0	12	799	25	0	104	1	129	27	1424	1451
07:00 PM	1	84	1	4	86	1	1	0	0	2	20	115	1	3	136	2	0	11	0	13	7	237	244
07:15 PM	0	93	3	5	96	0	0	0	0	0	22	140	1	3	163	2	0	22	2	24	10	283	293
07:30 PM	0	82	6	0	88	2	0	0	0	2	19	131	0	3	150	3	0	16	0	19	3	259	262
07:45 PM	0	84	7	3	91	1	0	1	0	2	16	143	0	6	159	6	1	17	0	24	9	276	285
Total	1	343	17	12	361	4	1	1	0	6	77	529	2	15	608	13	1	66	2	80	29	1055	1084
Grand Total	10	194	97	60	2048	5	1	2	0	8	704	2720	2	65	3426	60	2	413	17	475	142	5957	6099
Apprch %	0.5	94.8	4.7			62.5	12.5	25			20.5	79.4	0.1			12.6	0.4	86.9					
Total %	0.2	32.6	1.6		34.4	0.1	0	0		0.1	11.8	45.7	0		57.5	1	0	6.9		8	2.3	97.7	

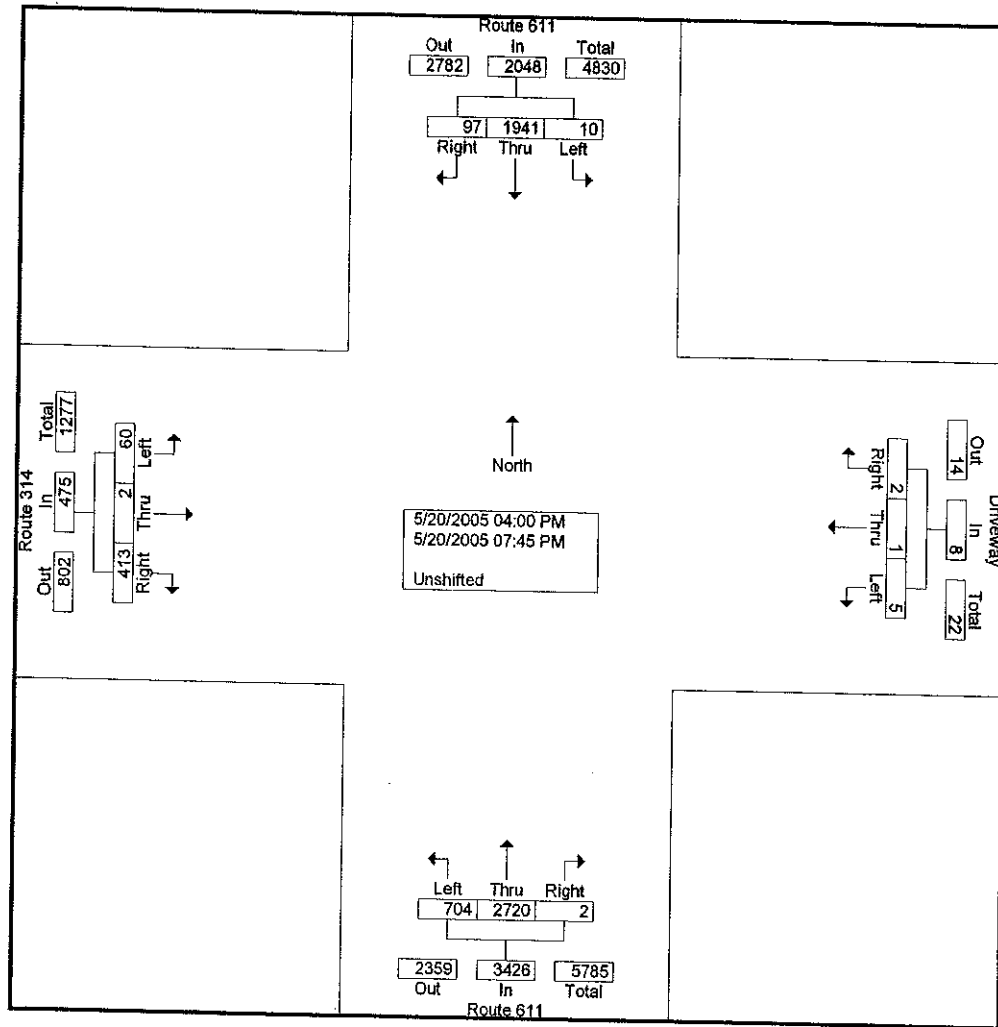

Start Time	Route 611 Southbound				Driveway Westbound				Route 611 Northbound				Route 314 Eastbound				Int. Total
	Left	Thru	Right	App. Total	Left	Thru	Right	App. Total	Left	Thru	Right	App. Total	Left	Thru	Right	App. Total	
Peak Hour Analysis from 04:00 PM to 07:45 PM - Peak 1 of 1																	
Peak Hour for Entire Intersection Begins at 04:30 PM																	
04:30 PM	1	198	4	203	0	0	1	1	81	197	0	278	2	0	32	34	516
04:45 PM	1	150	9	160	0	0	0	0	61	191	0	252	5	0	48	53	465
05:00 PM	0	111	6	117	1	0	0	1	67	196	0	263	0	0	34	34	415
05:15 PM	2	124	12	138	0	0	0	0	78	207	0	285	2	0	18	20	443
Total Volume	4	583	31	618	1	0	1	2	287	791	0	1078	9	0	132	141	1839
% App. Total	0.6	94.3	5		50	0	50		26.6	73.4	0		6.4	0	93.6		
PHF	.500	.736	.646	.761	.250	.000	.250	.500	.886	.955	.000	.946	.450	.000	.688	.665	.891

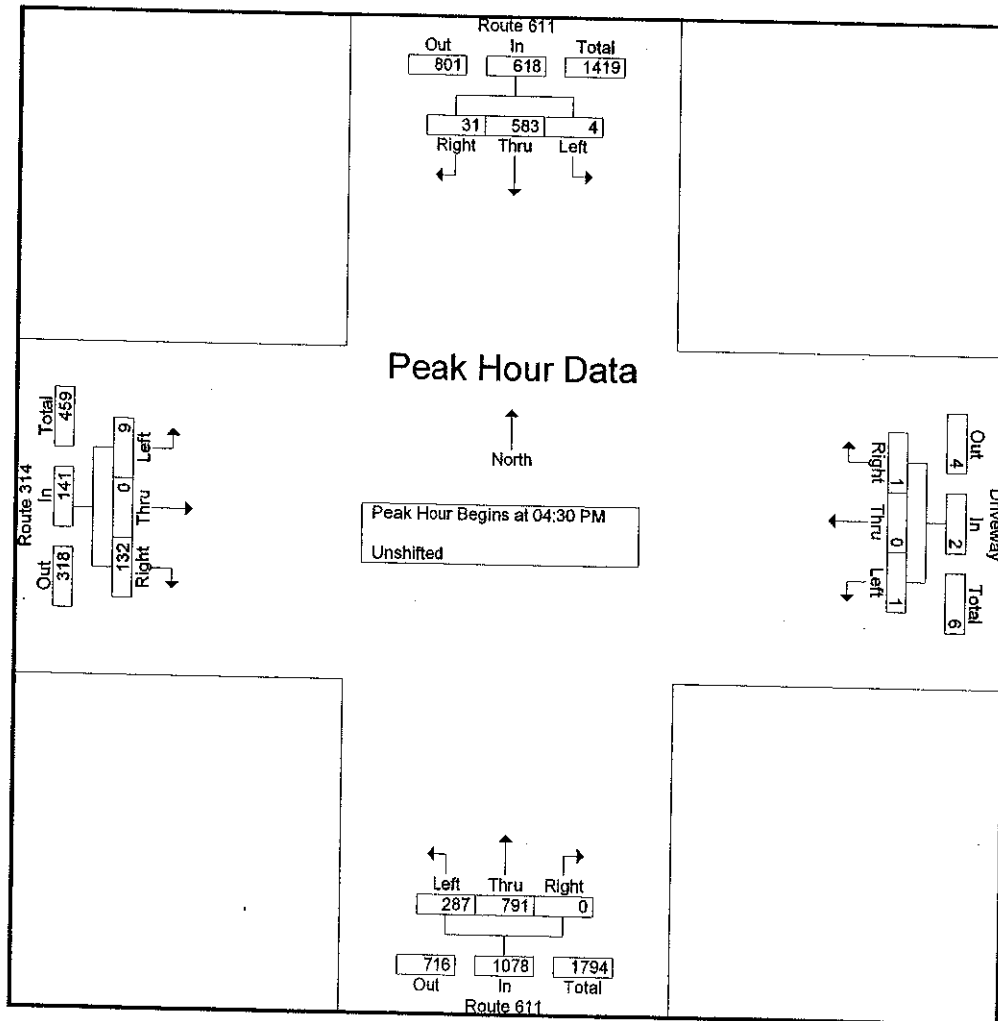



Counter: IMC 002  
 Counted By: E. Mountz  
 Weather: clear  
 1As: PMWR611

File Name : PMWR611  
 Site Code : 00000000  
 Start Date : 5/20/2005  
 Page No : 1

Groups Printed- Unshifted

Start Time	Route 611 Southbound					Woodland Rd. Westbound					Route 611 Northbound					Big Daddy's Eastbound					Exclu. Total	Inclu. Total	Int. Total
	Left	Thru	Right	Truck	App. Total	Left	Thru	Right	Truck	App. Total	Left	Thru	Right	Truck	App. Total	Left	Thru	Right	Truck	App. Total			
Factor	1.0	1.0	1.0	1.0		1.0	1.0	1.0	1.0		1.0	1.0	1.0	1.0		1.0	1.0	1.0	1.0				
04:00 PM	6	124	1	5	131	25	1	9	1	35	2	139	15	4	156	1	0	0	0	1	10	323	333
04:15 PM	10	161	1	8	172	13	1	11	0	25	1	175	17	5	193	1	0	1	0	2	13	392	405
04:30 PM	10	187	2	2	199	12	1	10	1	23	1	182	12	1	195	1	1	2	0	4	4	421	425
04:45 PM	13	142	3	2	158	11	1	9	1	21	0	172	22	3	194	2	0	0	0	2	6	375	381
Total	39	614	7	17	660	61	4	39	3	104	4	668	66	13	738	5	1	3	0	9	33	1511	1544
05:00 PM	5	115	1	0	121	11	4	12	0	27	3	173	16	1	192	0	1	0	0	1	1	341	342
05:15 PM	4	103	3	0	110	16	1	7	0	24	13	186	12	0	211	1	2	0	0	3	0	348	348
05:30 PM	4	112	2	1	118	17	5	5	1	27	5	185	13	3	203	0	0	0	0	0	5	348	353
05:45 PM	5	110	0	3	115	14	3	1	0	18	6	175	16	4	197	1	1	2	0	4	7	334	341
Total	18	440	6	4	464	58	13	25	1	96	27	719	57	8	803	2	4	2	0	8	13	1371	1384
06:00 PM	13	107	2	0	122	22	1	3	3	26	8	163	22	4	193	4	1	4	0	9	7	350	357
06:15 PM	5	105	0	1	110	11	1	6	0	18	6	171	24	3	201	4	1	2	0	7	4	336	340
06:30 PM	9	103	0	2	112	9	1	9	0	19	4	135	29	3	168	3	2	1	0	6	5	305	310
06:45 PM	11	107	2	3	120	7	1	4	0	12	2	133	19	3	154	3	4	6	0	13	6	299	305
Total	38	422	4	6	464	49	4	22	3	75	20	602	94	13	716	14	8	13	0	35	22	1290	1312
07:00 PM	3	75	0	2	78	9	2	6	2	17	2	123	14	2	139	3	2	3	0	8	6	242	248
07:15 PM	4	87	1	3	92	11	0	3	0	14	3	125	6	3	134	3	0	0	0	3	6	243	249
07:30 PM	2	80	0	0	82	10	0	9	0	19	3	127	14	2	144	0	0	4	0	4	2	249	251
07:45 PM	3	74	1	2	78	2	0	7	0	9	3	136	14	5	153	4	1	3	0	8	7	248	255
Total	12	316	2	7	330	32	2	25	2	59	11	511	48	12	570	10	3	10	0	23	21	982	1003
Grand Total	107	179	19	34	1918	200	23	111	9	334	62	250	265	46	2827	31	16	28	0	75	89	5154	5243
Apprch %	5.6	93.4	1			59.9	6.9	33.2			2.2	88.4	9.4			41.3	21.3	37.3					
Total %	2.1	34.8	0.4		37.2	3.9	0.4	2.2		6.5	1.2	48.5	5.1		54.9	0.6	0.3	0.5		1.5	1.7	98.3	

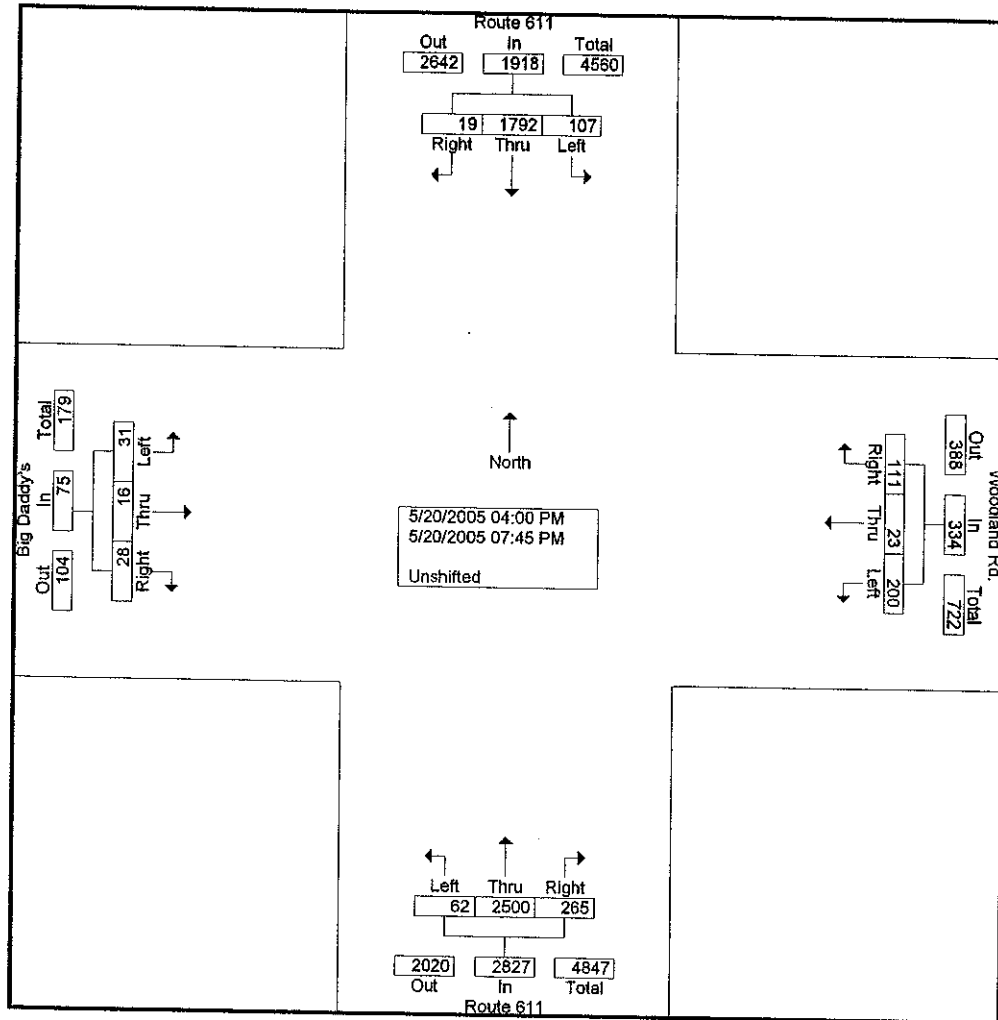

Start Time	Route 611 Southbound				Woodland Rd. Westbound				Route 611 Northbound				Big Daddy's Eastbound				Int. Total
	Left	Thru	Right	App. Total	Left	Thru	Right	App. Total	Left	Thru	Right	App. Total	Left	Thru	Right	App. Total	
Peak Hour Analysis From 04:00 PM to 07:45 PM - Peak 1 of 1																	
Peak Hour for Entire Intersection Begins at 04:15 PM																	
04:15 PM	10	161	1	172	13	1	11	25	1	175	17	193	1	0	1	2	392
04:30 PM	10	187	2	199	12	1	10	23	1	182	12	195	1	1	2	4	421
04:45 PM	13	142	3	158	11	1	9	21	0	172	22	194	2	0	0	2	375
05:00 PM	5	115	1	121	11	4	12	27	3	173	16	192	0	1	0	1	341
Total Volume	38	605	7	650	47	7	42	96	5	702	67	774	4	2	3	9	1529
% App. Total	5.8	93.1	1.1		49	7.3	43.8		0.6	90.7	8.7		44.4	22.2	33.3		
PHF	.731	.809	.583	.817	.904	.438	.875	.889	.417	.964	.761	.992	.500	.500	.375	.563	.908

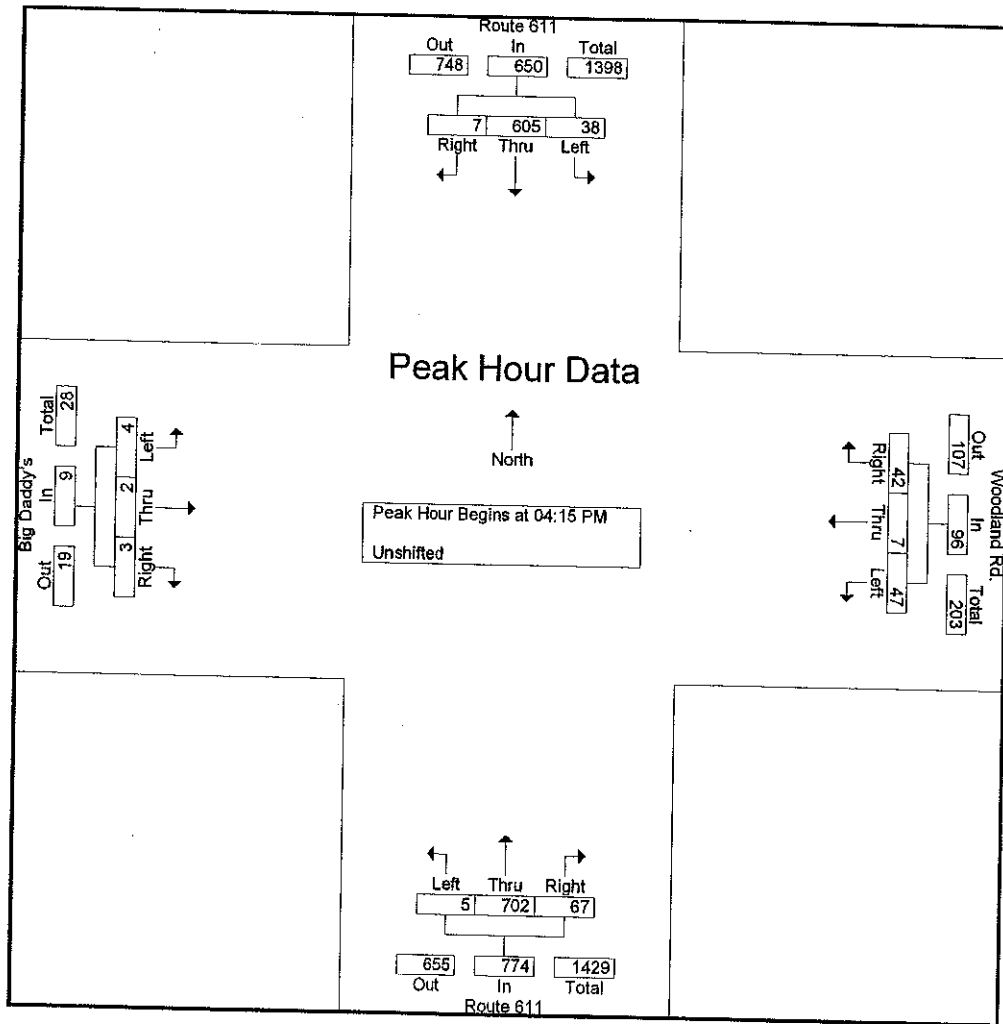

Job #: CLO.A.0008  
 Date: 5/20/05 (Friday)  
 Technician: E. Mountz

Turning Movements To/From Strickland's Road								
Time	From SB Route 611	From NB Route 611	From Big Daddy's	From Woodland Road	To SB Route 611	To NB Route 611	To Big Daddy's	To Woodland Road
4:00 - 4:15 PM								
4:15 - 4:30 PM								
4:30 - 4:45 PM								
4:45 - 5:00 PM								
5:00 - 5:15 PM								
5:15 - 5:30 PM								
5:30 - 5:45 PM								
5:45 - 6:00 PM								
6:00 - 6:15 PM								
6:15 - 6:30 PM								
6:30 - 6:45 PM								
6:45 - 7:00 PM								
7:00 - 7:15 PM								
7:15 - 7:30 PM								
7:30 - 7:45 PM								
7:45 - 8:00 PM								

Peak Hour

Counter: TPD 4  
 Counted By: W. Wagner  
 Weather: PRT Cloudy Cool

File Name : PM\_RT611MR  
 Site Code : 00055555  
 Start Date : 5/20/2005  
 Page No : 1

Groups Printed- Unshifted

Start Time	Route 611 Southbound					Meadowside Rd. Westbound					Route 611 Northbound					Trinity Hill Rd Eastbound					Exclu. Total	Inclu. Total	Int. Total
	Left	Thru	Right	Trucks	App. Total	Left	Thru	Right	Trucks	App. Total	Left	Thru	Right	Trucks	App. Total	Left	Thru	Right	Trucks	App. Total			
Factor	1.0	1.0	1.0	1.0		1.0	1.0	1.0	1.0		1.0	1.0	1.0	1.0		1.0	1.0	1.0	1.0				
04:00 PM	1	132	0	7	133	0	0	2	1	2	1	147	0	6	148	0	1	0	0	1	14	284	298
04:15 PM	0	177	0	11	177	0	0	2	0	2	1	182	0	6	183	0	0	1	0	1	17	363	380
04:30 PM	2	198	0	7	200	1	1	4	0	6	0	193	1	3	194	0	0	0	0	0	10	400	410
04:45 PM	1	155	1	8	157	0	0	1	0	1	0	184	0	2	184	0	0	1	0	1	10	343	353
Total	4	662	1	33	667	1	1	9	1	11	2	706	1	17	709	0	1	2	0	3	51	1390	1441
05:00 PM	2	124	0	4	126	0	0	3	0	3	2	187	0	0	189	0	0	1	0	1	4	319	323
05:15 PM	0	105	0	1	105	0	0	0	0	0	0	194	0	1	194	0	0	0	0	0	2	299	301
05:30 PM	1	124	0	5	125	1	0	0	0	1	1	190	0	4	191	0	0	2	0	2	9	319	328
05:45 PM	1	127	0	2	128	0	0	2	0	2	0	183	0	6	183	0	0	0	0	0	8	313	321
Total	4	480	0	12	484	1	0	5	0	6	3	754	0	11	757	0	0	3	0	3	23	1250	1273
06:00 PM	1	118	0	0	119	0	0	1	0	1	0	168	1	4	169	0	0	0	0	0	4	289	293
06:15 PM	0	124	0	5	124	0	0	1	0	1	1	173	1	4	175	0	0	2	0	2	9	302	311
06:30 PM	1	119	0	2	120	0	0	0	0	0	0	143	0	3	143	0	0	0	0	0	5	263	268
06:45 PM	1	121	1	3	123	1	0	1	0	2	0	142	0	5	142	0	0	0	0	0	8	267	275
Total	3	482	1	10	486	1	0	3	0	4	1	626	2	16	629	0	0	2	0	2	26	1121	1147
07:00 PM	1	83	0	5	84	0	0	0	0	0	2	133	0	1	135	0	0	0	0	0	6	219	225
07:15 PM	0	89	0	3	89	0	0	2	0	2	0	126	0	5	126	0	0	1	0	1	8	218	226
07:30 PM	1	78	0	1	79	0	0	0	0	0	1	141	0	5	142	0	0	0	0	0	6	221	227
07:45 PM	1	76	0	4	77	0	0	0	0	0	1	150	0	6	151	0	1	0	0	1	10	229	239
Total	3	326	0	13	329	0	0	2	0	2	4	550	0	17	554	0	1	1	0	2	30	887	917
Grand Total	14	1950	2	68	1966	3	1	19	1	23	10	2636	3	61	2649	0	2	8	0	10	130	4648	4778
Apprch %	0.7	99.2	0.1			13	4.3	82.6			0.4	99.5	0.1			0	20	80					
Total %	0.3	42	0		42.3	0.1	0	0.4		0.5	0.2	56.7	0.1		57	0	0	0.2		0.2	2.7	97.3	

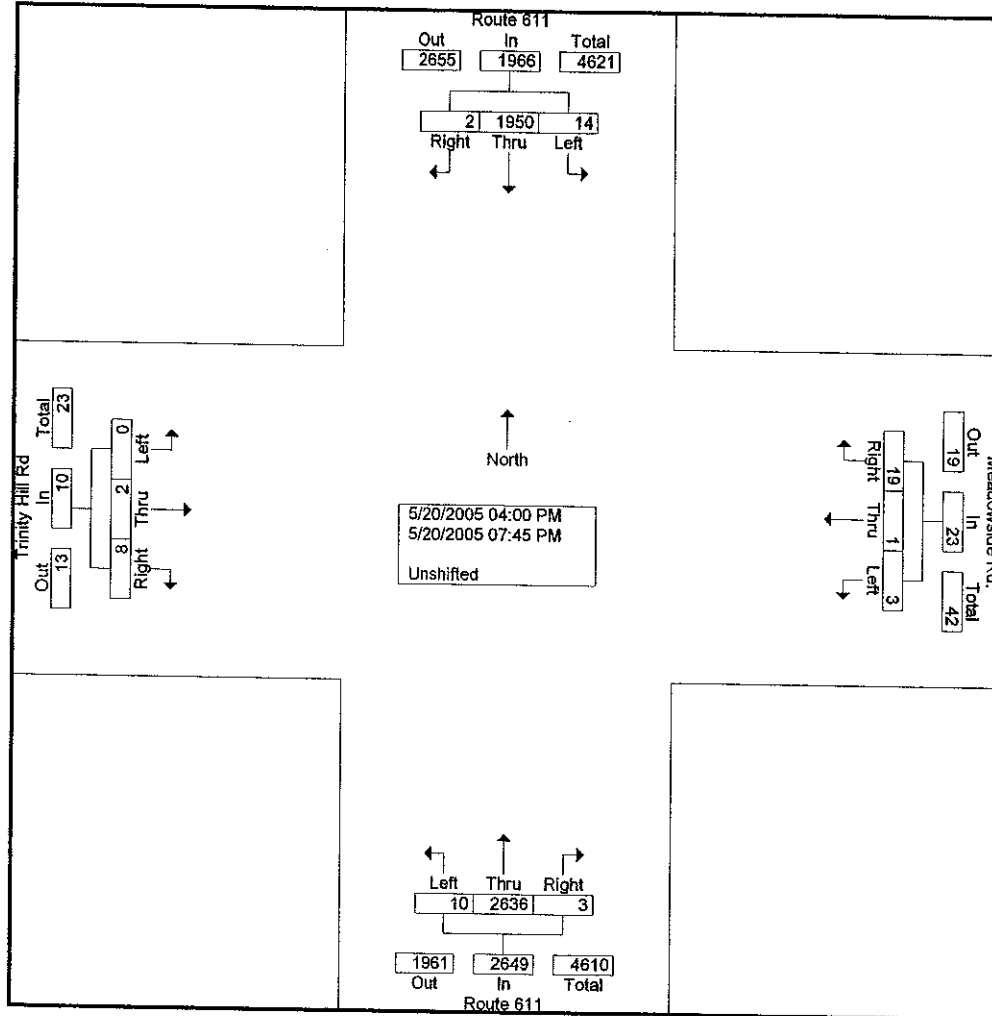

Start Time	Route 611 Southbound				Meadowside Rd. Westbound				Route 611 Northbound				Trinity Hill Rd Eastbound				Int. Total
	Left	Thru	Right	App. Total	Left	Thru	Right	App. Total	Left	Thru	Right	App. Total	Left	Thru	Right	App. Total	
Peak Hour Analysis from 04:00 PM to 07:45 PM - Peak 1 of 1																	
Peak Hour for Entire Intersection Begins at 04:15 PM																	
04:15 PM	0	177	0	177	0	0	2	2	1	182	0	183	0	0	1	1	363
04:30 PM	2	198	0	200	1	1	4	6	0	193	1	194	0	0	0	0	400
04:45 PM	1	155	1	157	0	0	1	1	0	184	0	184	0	0	1	1	343
05:00 PM	2	124	0	126	0	0	3	3	2	187	0	189	0	0	1	1	319
Total Volume	5	654	1	660	1	1	10	12	3	746	1	750	0	0	3	3	1425
% App. Total	0.8	99.1	0.2		8.3	8.3	83.3		0.4	99.5	0.1		0	0	100		
PHF	.625	.826	.250	.825	.250	.250	.625	.500	.375	.966	.250	.966	.000	.000	.750	.750	.891

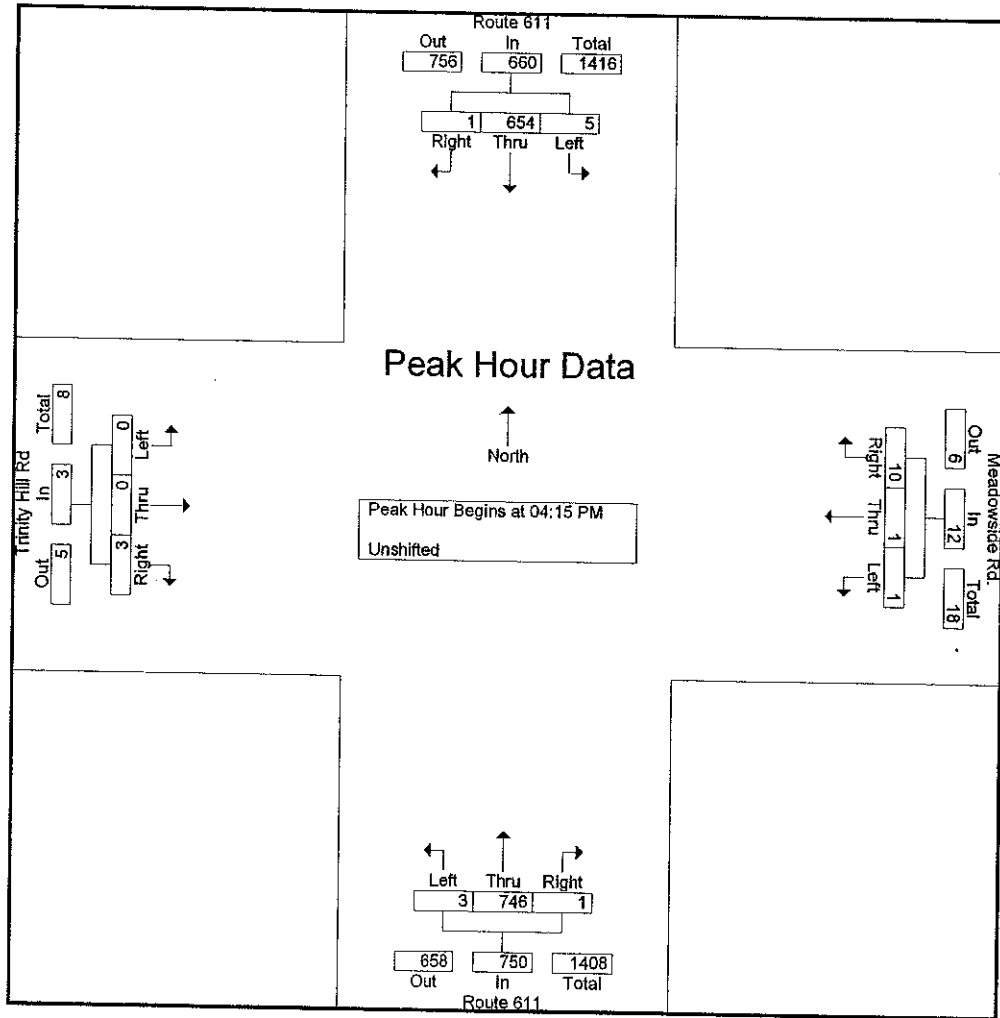

Counter:  
 Counted By:  
 Weather:

File Name : PM611GR  
 Site Code : 07314555  
 Start Date : 5/20/2005  
 Page No : 1

Groups Printed- Unshifted

Start Time	Route 611 Southbound					Grange Rd. Westbound					Route 611 Northbound					Eastbound					Exclu. Total	Inclu. Total	Int. Total
	Left	Thru	Right	Trucks	App. Total	Left	Thru	Right	Trucks	App. Total	Left	Thru	Right	Trucks	App. Total	Left	Thru	Right	Trucks	App. Total			
Factor	1.0	1.0	1.0	1.0		1.0	1.0	1.0	1.0		1.0	1.0	1.0	1.0		1.0	1.0	1.0	1.0				
04:00 PM	1	146	0	9	147	3	0	5	1	8	0	153	1	6	154	0	0	0	0	0	16	309	325
04:15 PM	5	172	0	6	177	0	0	2	0	2	0	188	3	5	191	0	0	0	0	0	11	370	381
04:30 PM	4	207	0	3	211	1	0	0	0	1	0	197	2	2	199	0	0	0	0	0	5	411	416
04:45 PM	1	137	0	4	138	1	0	2	0	3	0	184	1	2	185	0	0	0	0	0	6	326	332
Total	11	662	0	22	673	5	0	9	1	14	0	722	7	15	729	0	0	0	0	0	38	1416	1454
05:00 PM	2	125	0	1	127	0	0	3	0	3	0	193	2	0	195	0	0	0	0	0	1	325	326
05:15 PM	3	110	0	0	113	0	0	3	0	3	0	195	4	1	199	0	0	0	0	0	1	315	316
05:30 PM	3	120	0	3	123	0	0	1	0	1	0	193	0	4	193	0	0	0	0	0	7	317	324
05:45 PM	3	124	0	2	127	4	0	3	0	7	0	171	1	2	172	0	0	0	0	0	4	306	310
Total	11	479	0	6	490	4	0	10	0	14	0	752	7	7	759	0	0	0	0	0	13	1263	1276
06:00 PM	2	124	0	0	126	2	0	2	0	4	0	172	2	3	174	0	0	0	0	0	3	304	307
06:15 PM	2	120	0	4	122	4	0	2	0	6	0	163	4	3	167	0	0	0	0	0	7	295	302
06:30 PM	1	120	0	1	121	1	0	3	0	4	0	138	2	3	140	0	0	0	0	0	4	265	269
06:45 PM	3	117	0	4	120	1	0	1	0	2	0	143	2	3	145	0	0	0	0	0	7	267	274
Total	8	481	0	9	489	8	0	8	0	16	0	616	10	12	626	0	0	0	0	0	21	1131	1152
07:00 PM	1	92	0	5	93	1	0	0	0	1	0	127	2	1	129	0	0	0	0	0	6	223	229
07:15 PM	3	78	0	2	81	2	0	0	0	2	0	135	1	3	136	0	0	0	0	0	5	219	224
07:30 PM	0	79	0	0	79	2	0	0	0	2	0	136	2	2	138	0	0	0	0	0	2	219	221
07:45 PM	0	74	0	4	74	2	0	0	0	2	0	147	6	4	153	0	0	0	0	0	8	229	237
Total	4	323	0	11	327	7	0	0	0	7	0	545	11	10	556	0	0	0	0	0	21	890	911
Grand Total	34	1945	0	48	1979	24	0	27	1	51	0	2635	35	44	2670	0	0	0	0	0	93	4700	4793
Apprch %	1.7	98.3	0			47.1	0	52.9			0	98.7	1.3			0	0	0					
Total %	0.7	41.4	0		42.1	0.5	0	0.6		1.1	0	56.1	0.7		56.8	0	0	0	0	0	1.9	98.1	



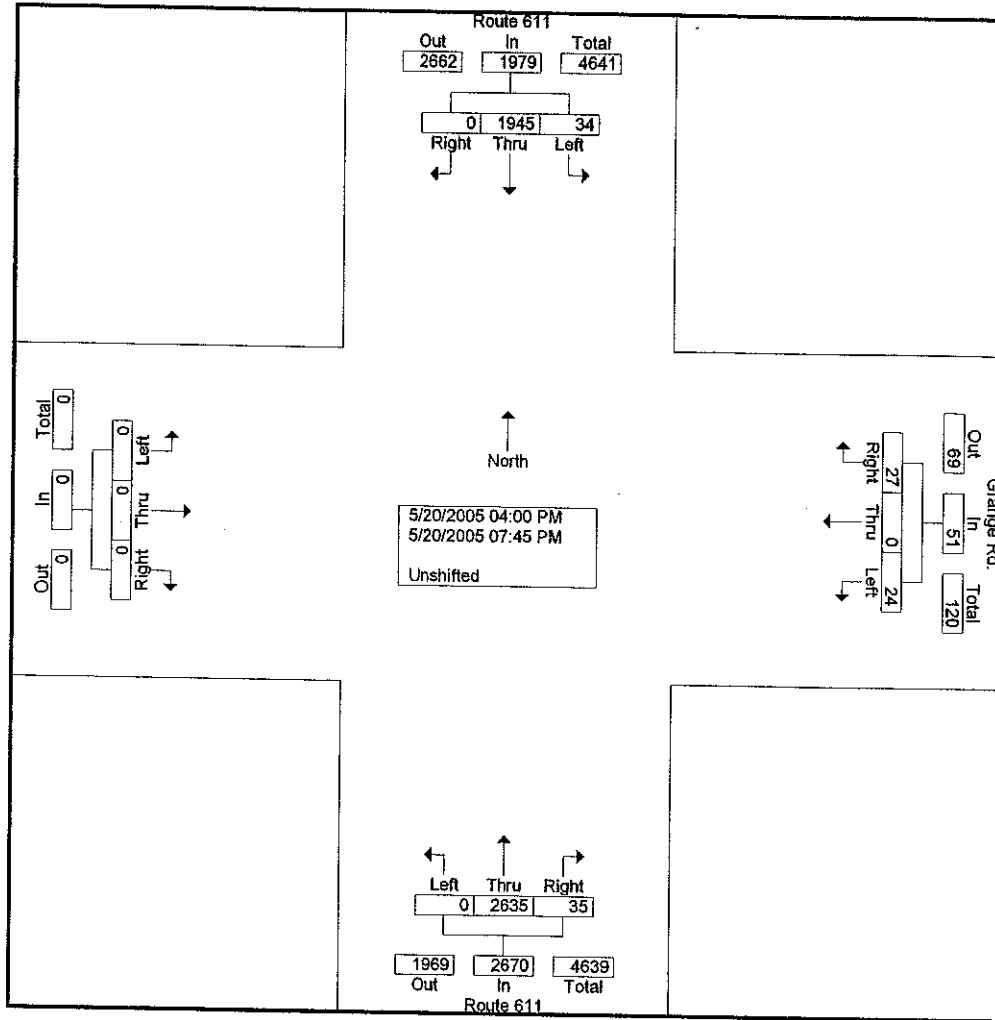

Start Time	Route 611 Southbound				Grange Rd. Westbound				Route 611 Northbound				Eastbound				Int. Total
	Left	Thru	Right	App. Total	Left	Thru	Right	App. Total	Left	Thru	Right	App. Total	Left	Thru	Right	App. Total	
Peak Hour Analysis From 04:00 PM to 05:45 PM - Peak 1 of 1																	
Peak Hour for Entire Intersection Begins at 04:15 PM																	
04:15 PM	5	172	0	177	0	0	2	2	0	188	3	191	0	0	0	0	370
04:30 PM	4	207	0	211	1	0	0	1	0	197	2	199	0	0	0	0	411
04:45 PM	1	137	0	138	1	0	2	3	0	184	1	185	0	0	0	0	326
05:00 PM	2	125	0	127	0	0	3	3	0	193	2	195	0	0	0	0	325
Total Volume	12	641	0	653	2	0	7	9	0	762	8	770	0	0	0	0	1432
% App. Total	1.8	98.2	0		22.2	0	77.8		0	99	1		0	0	0		
PHF	.600	.774	.000	.774	.500	.000	.583	.750	.000	.967	.667	.967	.000	.000	.000	.000	.871

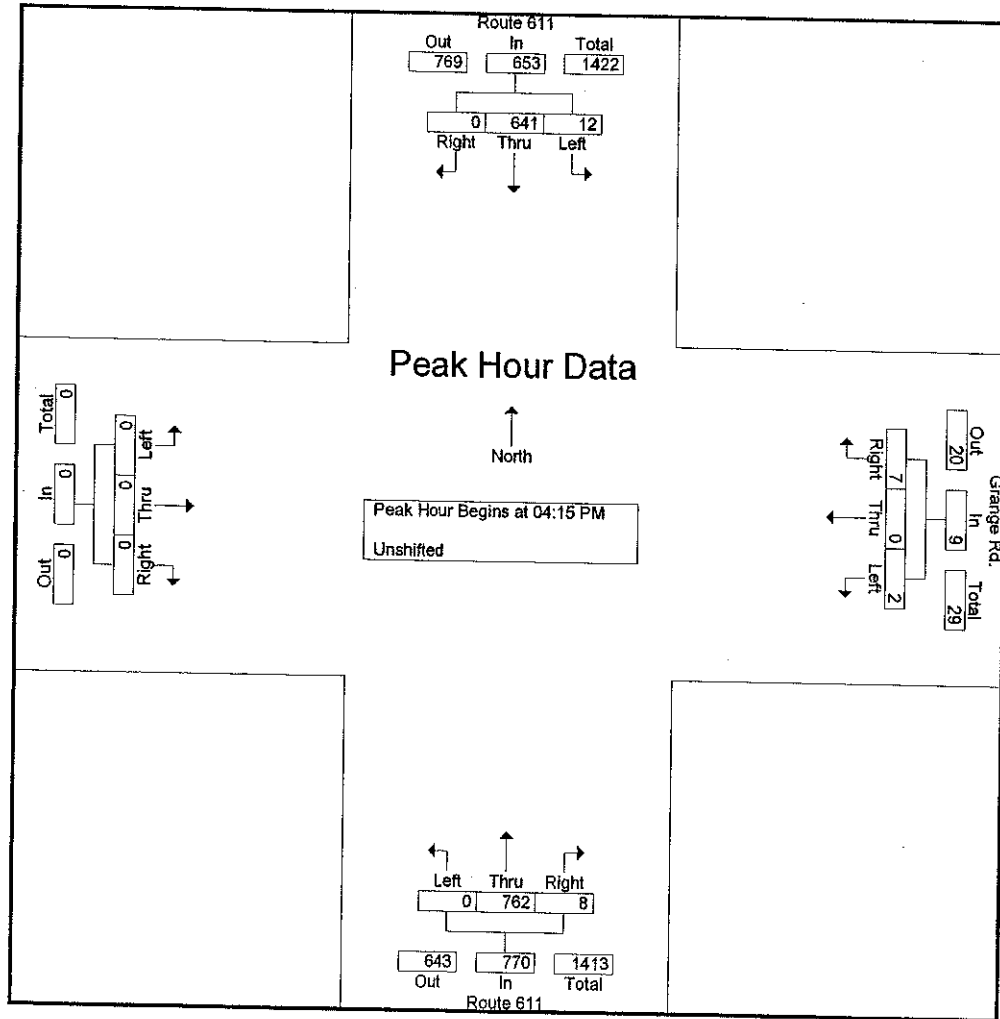

Counter: 2  
 Counted By: R. Hassler  
 Weather: Clear  
 and As: PMSAWR-revised

File Name : PMSAWR-revised  
 Site Code : 00000000  
 Start Date : 5/20/2005  
 Page No : 1

**Groups Printed- Unshifted**

Start Time Factor	Southbound					Woodland Rd. Westbound					School Access Road Northbound					Woodland Rd. Eastbound					Excl. Total	Incl. Total	Int. Total
	Left	Thru	Right	Truck	App. Total	Left	Thru	Right	Truck	App. Total	Left	Thru	Right	Truck	App. Total	Left	Thru	Right	Truck	App. Total			
	1.0	1.0	1.0	1.0		1.0	1.0	1.0	1.0		1.0	1.0	1.0	1.0		1.0	1.0	1.0	1.0				
02:00 PM	0	0	0	0	0	0	17	0	0	17	0	0	0	0	0	0	19	1	0	20	0	37	37
02:15 PM	0	0	0	0	0	1	27	0	1	28	0	0	1	0	1	0	14	0	1	14	2	43	45
02:30 PM	0	0	0	0	0	1	24	0	2	25	0	0	0	0	0	0	28	3	1	31	3	56	59
02:45 PM	0	0	0	0	0	3	18	0	0	21	56	0	22	1	78	0	12	6	0	18	1	117	118
<b>Total</b>	0	0	0	0	0	5	86	0	3	91	56	0	23	1	79	0	73	10	2	83	6	253	259
03:00 PM	0	0	0	0	0	6	13	0	0	19	20	0	9	0	29	0	14	18	2	32	2	80	82
03:15 PM	0	0	0	0	0	2	12	0	2	14	25	0	2	0	27	0	18	14	3	32	5	73	78
03:30 PM	0	0	0	0	0	1	14	0	2	15	21	0	9	0	30	0	13	6	2	19	4	64	68
03:45 PM	0	0	0	0	0	0	17	0	1	17	32	0	9	0	41	0	15	7	0	22	1	80	81
<b>Total</b>	0	0	0	0	0	9	56	0	5	65	98	0	29	0	127	0	60	45	7	105	12	297	309
04:00 PM	0	0	0	0	0	2	16	0	0	18	15	0	3	0	18	0	16	7	2	23	2	59	61
04:15 PM	0	0	0	0	0	5	11	0	1	16	11	0	8	0	19	0	20	7	3	27	4	62	66
04:30 PM	0	0	0	0	0	5	11	0	1	16	11	0	5	0	16	0	16	8	0	24	1	56	57
04:45 PM	0	0	0	0	0	3	13	0	2	16	9	0	2	0	11	0	25	14	2	39	4	66	70
<b>Total</b>	0	0	0	0	0	15	51	0	4	66	46	0	18	0	64	0	77	36	7	113	11	243	254
05:00 PM	0	0	0	0	0	0	0	0	0	0	0	0	0	0	0	0	0	0	0	0	0	0	0
05:15 PM	0	0	0	0	0	0	0	0	0	0	0	0	0	0	0	0	0	0	0	0	0	0	0
05:30 PM	0	0	0	0	0	0	0	0	0	0	0	0	0	0	0	0	0	0	0	0	0	0	0
05:45 PM	0	0	0	0	0	0	0	0	0	0	0	0	0	0	0	0	0	0	0	0	0	0	0
<b>Total</b>	0	0	0	0	0	0	0	0	0	0	0	0	0	0	0	0	0	0	0	0	0	0	0
06:00 PM	0	0	0	0	0	0	0	0	0	0	0	0	0	0	0	0	0	0	0	0	0	0	0
06:15 PM	0	0	0	0	0	0	0	0	0	0	0	0	0	0	0	0	0	0	0	0	0	0	0
06:30 PM	0	0	0	0	0	15	14	0	0	29	10	0	1	0	11	0	27	17	0	44	0	84	84
06:45 PM	0	0	0	0	0	10	7	0	0	17	1	0	2	0	3	0	17	19	0	36	0	56	56
<b>Total</b>	0	0	0	0	0	25	21	0	0	46	11	0	3	0	14	0	44	36	0	80	0	140	140
07:00 PM	0	0	0	0	0	3	11	0	0	14	8	0	1	0	9	0	11	4	1	15	1	38	39
07:15 PM	0	0	0	0	0	2	7	0	0	9	3	0	2	0	5	0	9	4	0	13	0	27	27
07:30 PM	0	0	0	0	0	1	16	0	0	17	10	0	2	0	12	0	17	3	0	20	0	49	49
07:45 PM	0	0	0	0	0	2	8	0	0	10	4	0	0	0	4	0	15	5	0	20	0	34	34
<b>Total</b>	0	0	0	0	0	8	42	0	0	50	25	0	5	0	30	0	52	16	1	68	1	148	149
<b>Grand Total</b>	0	0	0	0	0	62	256	0	12	318	236	0	78	1	314	0	306	143	17	449	30	1081	1111
<b>Apprch %</b>	0	0	0	0	0	19.5	80.5	0	0	0	75.2	0	24.8	0	0	0	68.2	31.8	0	0	2.7	97.3	0
<b>Total %</b>	0	0	0	0	0	5.7	23.7	0	0	29.4	21.8	0	7.2	0	29	0	28.3	13.2	0	41.5	2.7	97.3	0

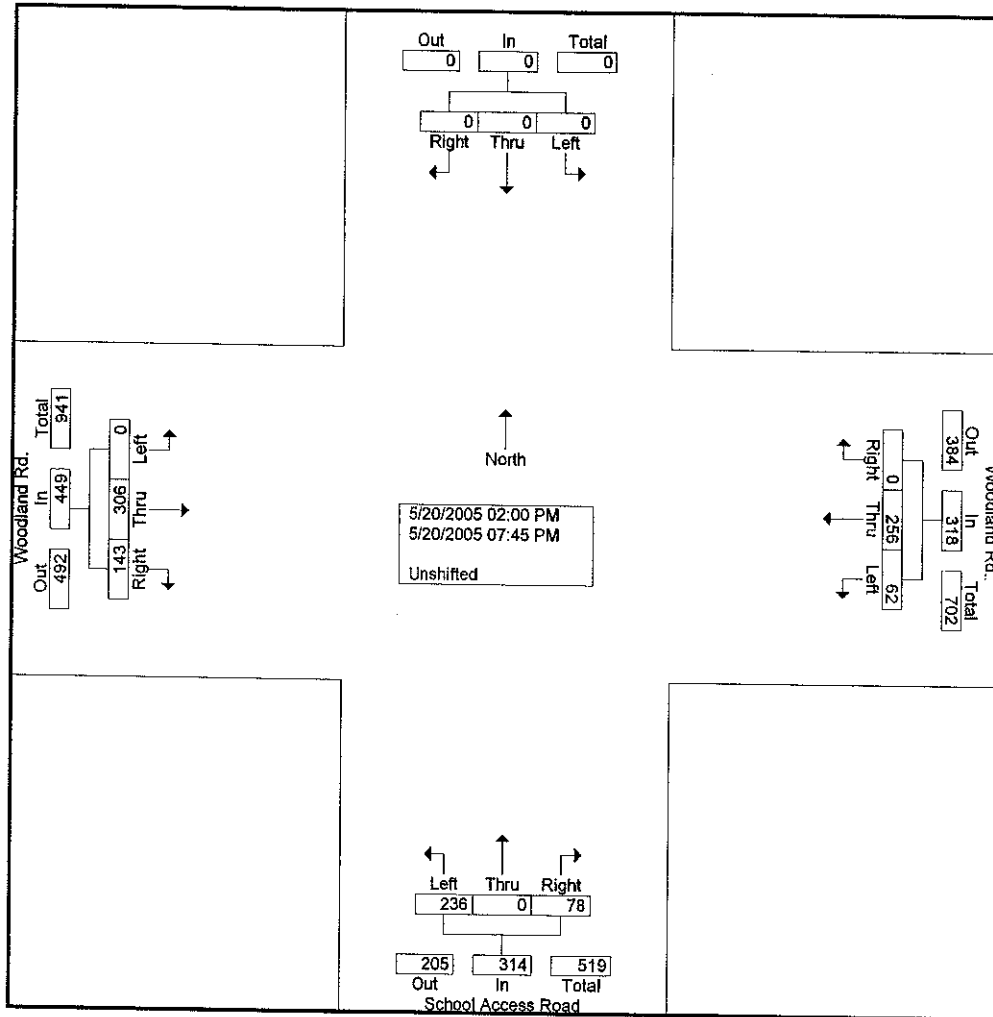

Start Time	Southbound				Woodland Rd. Westbound				School Access Road Northbound				Woodland Rd. Eastbound				Int. Total
	Left	Thru	Right	App. Total	Left	Thru	Right	App. Total	Left	Thru	Right	App. Total	Left	Thru	Right	App. Total	
Peak Hour Analysis From 02:00 PM to 07:45 PM - Peak 1 of 1																	
Peak Hour for Entire Intersection Begins at 02:45 PM																	
02:45 PM	0	0	0	0	3	18	0	21	56	0	22	78	0	12	6	18	117
03:00 PM	0	0	0	0	6	13	0	19	20	0	9	29	0	14	18	32	80
03:15 PM	0	0	0	0	2	12	0	14	25	0	2	27	0	18	14	32	73
03:30 PM	0	0	0	0	1	14	0	15	21	0	9	30	0	13	6	19	64
Total Volume	0	0	0	0	12	57	0	69	122	0	42	164	0	57	44	101	334
% App. Total	0	0	0	0	17.4	82.6	0		74.4	0	25.6		0	56.4	43.6		
PHF	.000	.000	.000	.000	.500	.792	.000	.821	.545	.000	.477	.526	.000	.792	.611	.789	.714

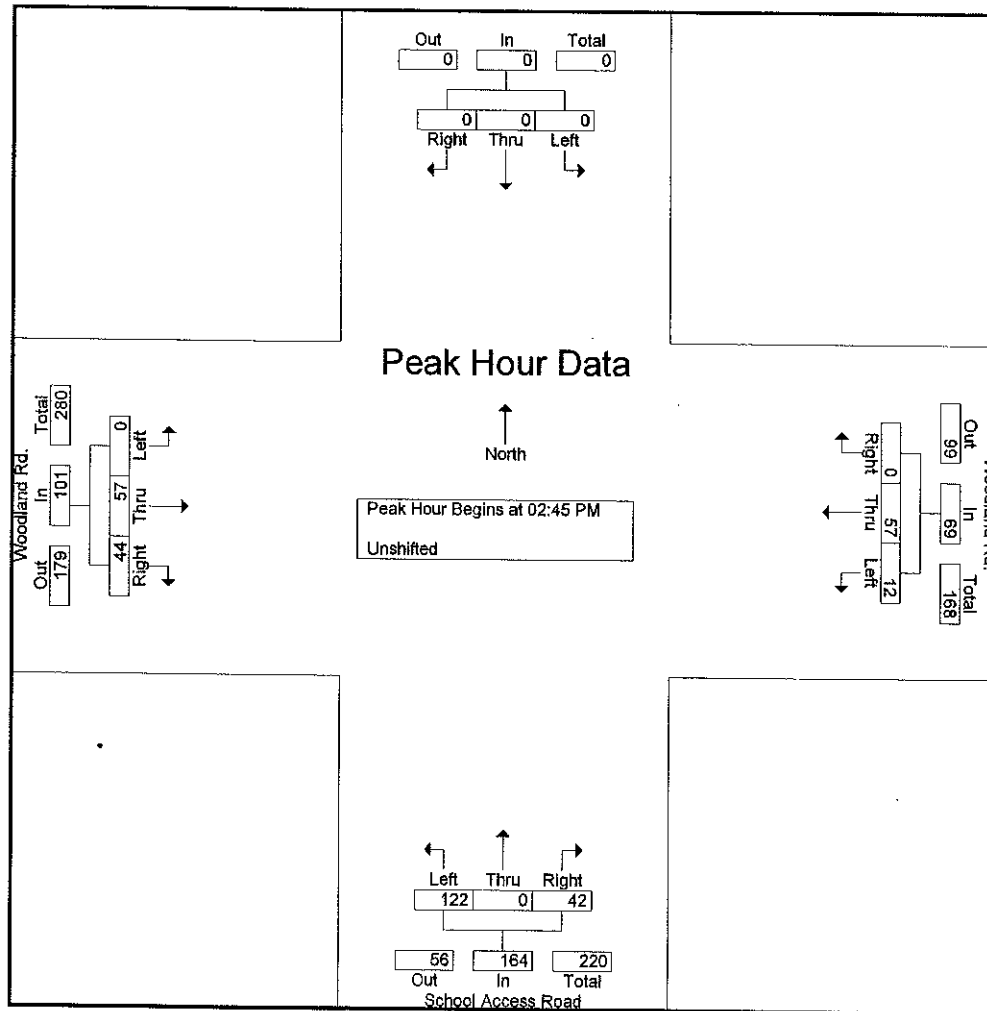

Counter: 9  
 Counted By: R. Kearney  
 Weather: clear  
 As: PMWRBR

File Name : PMWRBR  
 Site Code : 0000000  
 Start Date : 5/20/2005  
 Page No : 1

Groups Printed- Unshifted

Start Time	Southbound					Woodland Rd. Westbound					Bowman Rd. Northbound					Woodland Rd. Eastbound					Exclu. Total	Inclu. Total	Int. Total
	Left	Thru	Right	Truck	App. Total	Left	Thru	Right	Truck	App. Total	Left	Thru	Right	Truck	App. Total	Left	Thru	Right	Truck	App. Total			
Factor	1.0	1.0	1.0	1.0		1.0	1.0	1.0	1.0		1.0	1.0	1.0	1.0		1.0	1.0	1.0	1.0				
04:00 PM	0	0	0	0	0	0	14	0	0	14	0	0	0	0	0	0	16	2	2	18			
04:15 PM	0	0	0	0	0	0	18	0	5	18	0	0	1	0	1	0	26	2	2	28	2	32	34
04:30 PM	0	0	0	0	0	0	14	0	3	14	2	0	2	0	4	0	15	4	2	19	7	47	54
04:45 PM	0	0	0	0	0	2	19	0	1	21	1	0	0	0	1	0	22	2	2	24	5	37	42
Total	0	0	0	0	0	2	65	0	9	67	3	0	3	0	6	0	79	10	8	89	3	46	49
05:00 PM	0	0	0	0	0	1	12	0	0	13	0	0	2	0	2	0	18	0	1	18	1	33	34
05:15 PM	0	0	0	0	0	0	24	0	0	24	1	0	1	0	2	0	14	1	0	15	0	41	41
05:30 PM	0	0	0	0	0	0	14	0	0	14	0	0	0	0	0	0	16	0	1	16	1	30	31
05:45 PM	0	0	0	0	0	0	24	0	2	24	0	0	0	0	0	0	15	0	1	15	3	39	42
Total	0	0	0	0	0	1	74	0	2	75	1	0	3	0	4	0	63	1	3	64	5	143	148
06:00 PM	0	0	0	0	0	0	31	0	2	31	0	0	0	0	0	0	22	0	0	22	2	53	55
06:15 PM	0	0	0	0	0	0	18	0	0	18	0	0	0	0	0	0	16	0	0	16	0	34	34
06:30 PM	0	0	0	0	0	0	33	0	0	33	0	0	1	0	1	0	27	1	0	28	0	62	62
06:45 PM	0	0	0	0	0	0	14	0	0	14	0	0	0	0	0	0	16	1	0	17	0	31	31
Total	0	0	0	0	0	0	96	0	2	96	0	0	1	0	1	0	81	2	0	83	2	180	182
07:00 PM	0	0	0	0	0	2	16	0	0	18	0	0	0	0	0	0	13	0	1	13	1	31	32
07:15 PM	0	0	0	0	0	0	10	0	0	10	0	0	0	0	0	0	15	0	0	15	0	25	25
07:30 PM	0	0	0	0	0	1	12	0	0	13	0	0	0	0	0	0	13	0	0	13	0	26	26
07:45 PM	0	0	0	0	0	2	10	0	0	12	1	0	0	0	1	0	17	1	0	18	0	31	31
Total	0	0	0	0	0	5	48	0	0	53	1	0	0	0	1	0	58	1	1	59	1	113	114
Grand Total	0	0	0	0	0	8	283	0	13	291	5	0	7	0	12	0	281	14	12	295	25	598	623
Apprch %	0	0	0			2.7	97.3	0			41.7	0	58.3			0	95.3	4.7					
Total %	0	0	0			1.3	47.3	0		48.7	0.8	0	1.2		2	0	47	2.3		49.3	4	96	

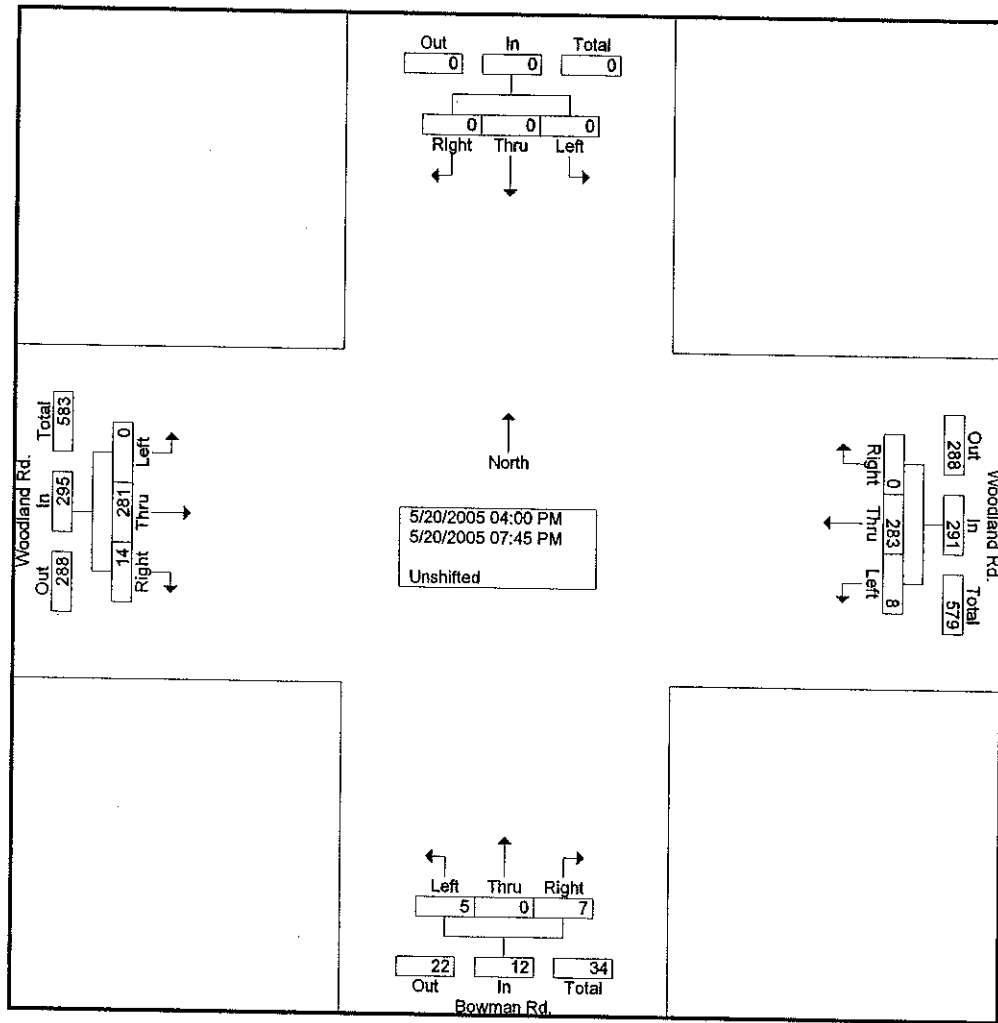

Start Time	Southbound				Woodland Rd. Westbound				Bowman Rd. Northbound				Woodland Rd. Eastbound				Int. Total
	Left	Thru	Right	App. Total	Left	Thru	Right	App. Total	Left	Thru	Right	App. Total	Left	Thru	Right	App. Total	
Peak Hour Analysis From 04:00 PM to 07:45 PM - Peak 1 of 1																	
Peak Hour for Entire Intersection Begins at 05:45 PM																	
05:45 PM	0	0	0	0	0	24	0	24	0	0	0	0	0	15	0	15	39
06:00 PM	0	0	0	0	0	31	0	31	0	0	0	0	0	22	0	22	53
06:15 PM	0	0	0	0	0	18	0	18	0	0	0	0	0	16	0	16	34
06:30 PM	0	0	0	0	0	33	0	33	0	0	1	1	0	27	1	28	62
Total Volume	0	0	0	0	0	106	0	106	0	0	1	1	0	80	1	81	188
% App. Total	0	0	0	0	0	100	0	100	0	0	100	100	0	98.8	1.2	81	188
PHF	.000	.000	.000	.000	.000	.803	.000	.803	.000	.000	.250	.250	.000	.741	.250	.723	.758

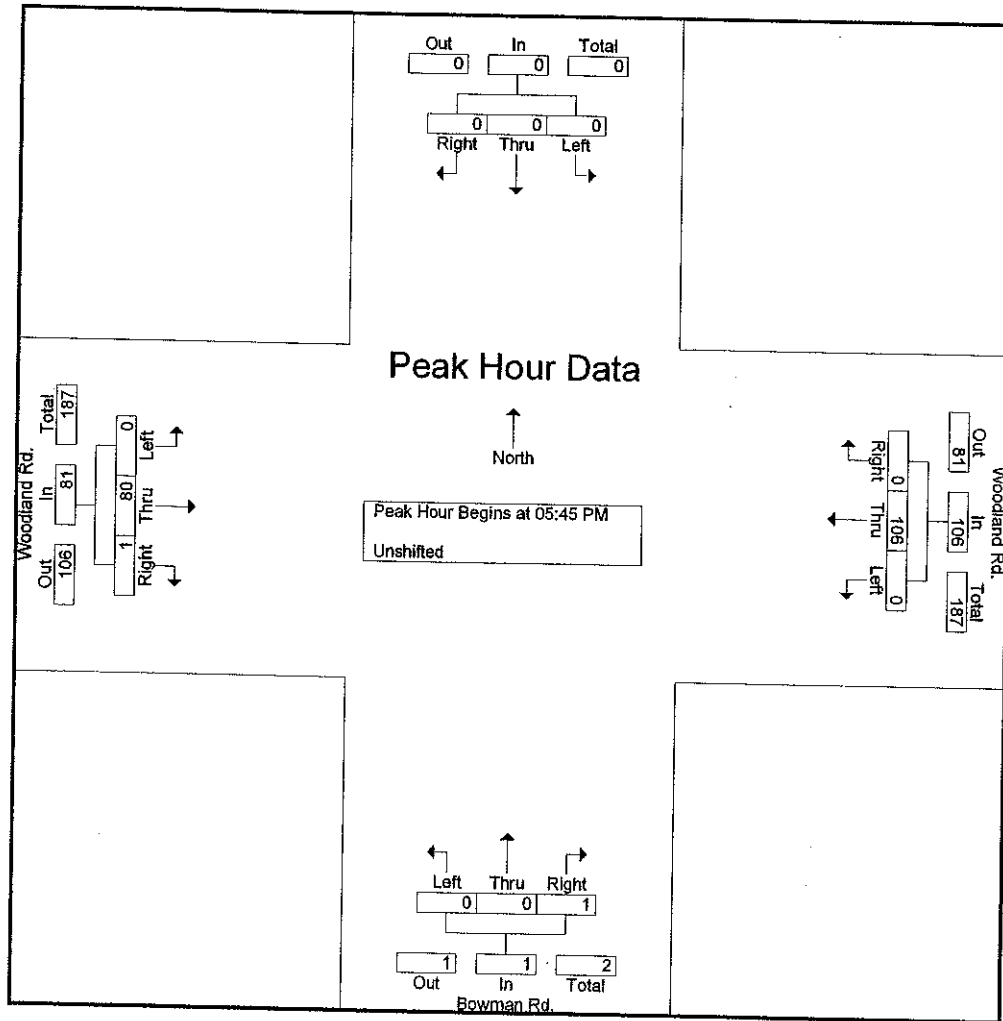



Counter: 1  
 Counted By: M. McGarrigle  
 Weather: clear  
 As: PMWRMR

File Name : PMWRMR  
 Site Code : 0052005  
 Start Date : 5/20/2005  
 Page No : 1

Groups Printed- Unshifted

Start Time	Meadowside Rd. Southbound					Woodland Rd. Westbound					Northbound					Woodland Rd. Eastbound					Exclu. Total	Inclu. Total	Int. Total
	Left	Thru	Right	Truck	App. Total	Left	Thru	Right	Truck	App. Total	Left	Thru	Right	Truck	App. Total	Left	Thru	Right	Truck	App. Total			
Factor	1.0	1.0	1.0	1.0		1.0	1.0	1.0	1.0		1.0	1.0	1.0	1.0		1.0	1.0	1.0	1.0				
04:00 PM	5	0	0	0	5	0	18	3	1	21	0	0	0	0	0	0	19	0	2	19			
04:15 PM	0	0	0	0	0	0	15	1	5	16	0	0	0	0	0	0	25	0	2	25	3	45	48
04:30 PM	0	0	0	0	0	0	12	3	1	15	0	0	0	0	0	1	18	0	0	19	7	41	48
04:45 PM	0	0	0	0	0	0	13	2	1	15	0	0	0	0	0	0	17	0	0	17	1	34	35
Total	5	0	0	0	5	0	58	9	8	67	0	0	0	0	0	1	79	0	4	80	12	152	164
05:00 PM	0	0	0	0	0	0	22	2	0	24	0	0	0	0	0	1	20	0	1	21	1	45	46
05:15 PM	0	0	1	0	1	0	19	1	0	20	0	0	0	0	0	0	18	0	0	18	0	39	39
05:30 PM	0	0	1	0	1	0	19	1	0	20	0	0	0	0	0	1	19	0	0	20	0	41	41
05:45 PM	0	0	1	0	1	0	22	1	2	23	0	0	0	0	0	0	20	0	0	20	2	44	46
Total	0	0	3	0	3	0	82	5	2	87	0	0	0	0	0	2	77	0	1	79	3	169	172
06:00 PM	1	0	0	0	1	0	32	0	2	32	0	0	0	0	0	0	17	0	1	17	3	50	53
06:15 PM	0	0	0	0	0	0	18	0	0	18	0	0	0	0	0	1	23	0	0	24	0	42	42
06:30 PM	1	0	1	0	2	0	26	0	0	26	0	0	0	0	0	1	25	0	0	26	0	54	54
06:45 PM	0	0	1	0	1	0	19	1	0	20	0	0	0	0	0	0	18	0	0	18	0	39	39
Total	2	0	2	0	4	0	95	1	2	96	0	0	0	0	0	2	83	0	1	85	3	185	188
07:00 PM	0	0	1	0	1	0	11	0	0	11	0	0	0	0	0	0	10	0	0	10	0	22	22
07:15 PM	0	0	0	0	0	0	11	1	0	12	0	0	0	0	0	1	9	0	0	10	0	22	22
07:30 PM	0	0	0	0	0	0	12	0	0	12	0	0	0	0	0	0	14	0	0	14	0	26	26
07:45 PM	0	0	1	0	1	0	9	0	0	9	0	0	0	0	0	2	11	0	0	13	0	23	23
Total	0	0	2	0	2	0	43	1	0	44	0	0	0	0	0	3	44	0	0	47	0	93	93
Grand Total	7	0	7	0	14	0	278	16	12	294	0	0	0	0	0	8	283	0	6	291	18	599	617
Apprch %	50	0	50			0	94.6	5.4			0	0	0			2.7	97.3	0					
Total %	1.2	0	1.2		2.3	0	46.4	2.7		49.1	0	0	0		0	1.3	47.2	0		48.6	2.9	97.1	

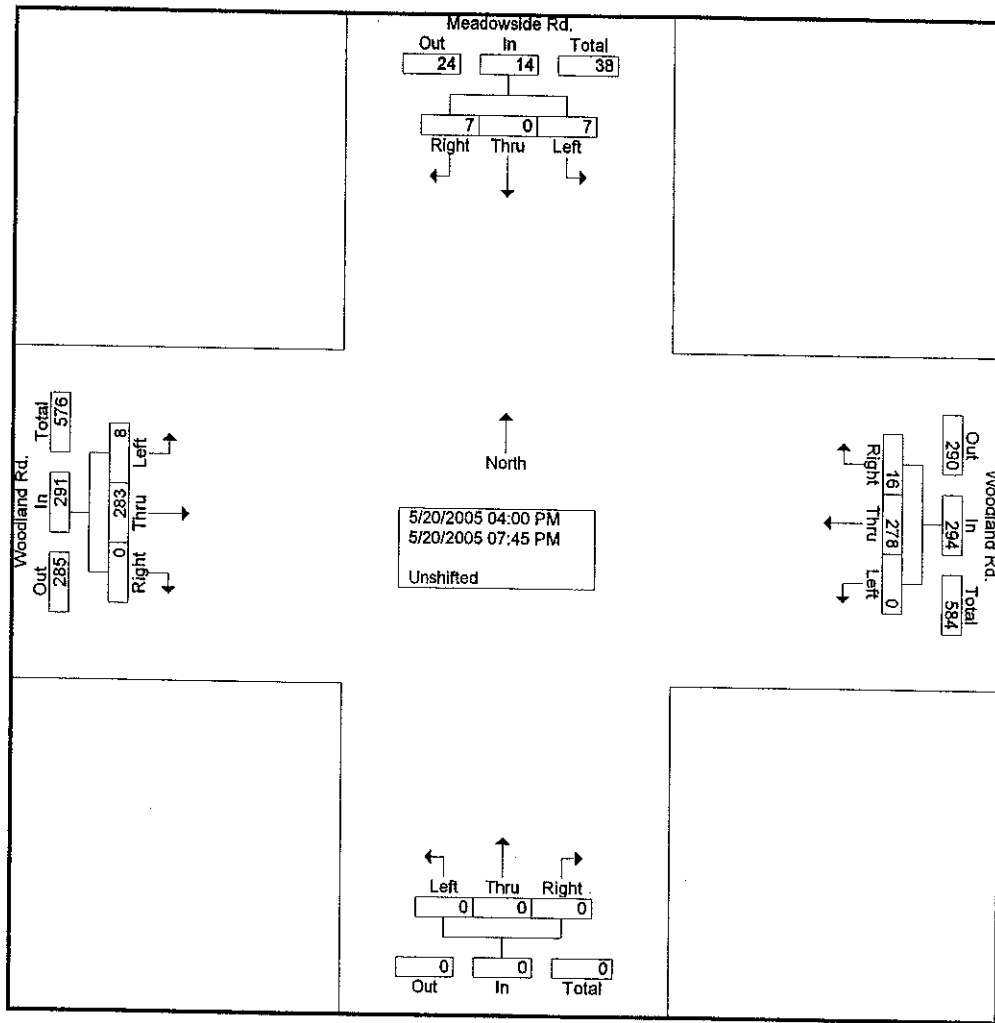

Start Time	Meadowsides Rd. Southbound				Woodland Rd. Westbound				Northbound				Woodland Rd. Eastbound				Int. Total
	Left	Thru	Right	App. Total	Left	Thru	Right	App. Total	Left	Thru	Right	App. Total	Left	Thru	Right	App. Total	
Peak Hour Analysis From 04:00 PM to 07:45 PM - Peak 1 of 1																	
Peak Hour for Entire Intersection Begins at 05:45 PM																	
05:45 PM	0	0	1	1	0	22	1	23	0	0	0	0	0	20	0	20	44
06:00 PM	1	0	0	1	0	32	0	32	0	0	0	0	0	17	0	17	50
06:15 PM	0	0	0	0	0	18	0	18	0	0	0	0	1	23	0	24	42
06:30 PM	1	0	1	2	0	26	0	26	0	0	0	0	1	25	0	26	54
Total Volume	2	0	2	4	0	98	1	99	0	0	0	0	2	85	0	87	190
% App. Total	50	0	50		0	99	1		0	0	0		2.3	97.7	0		
PHF	.500	.000	.500	.500	.000	.766	.250	.773	.000	.000	.000	.000	.500	.850	.000	.837	.880

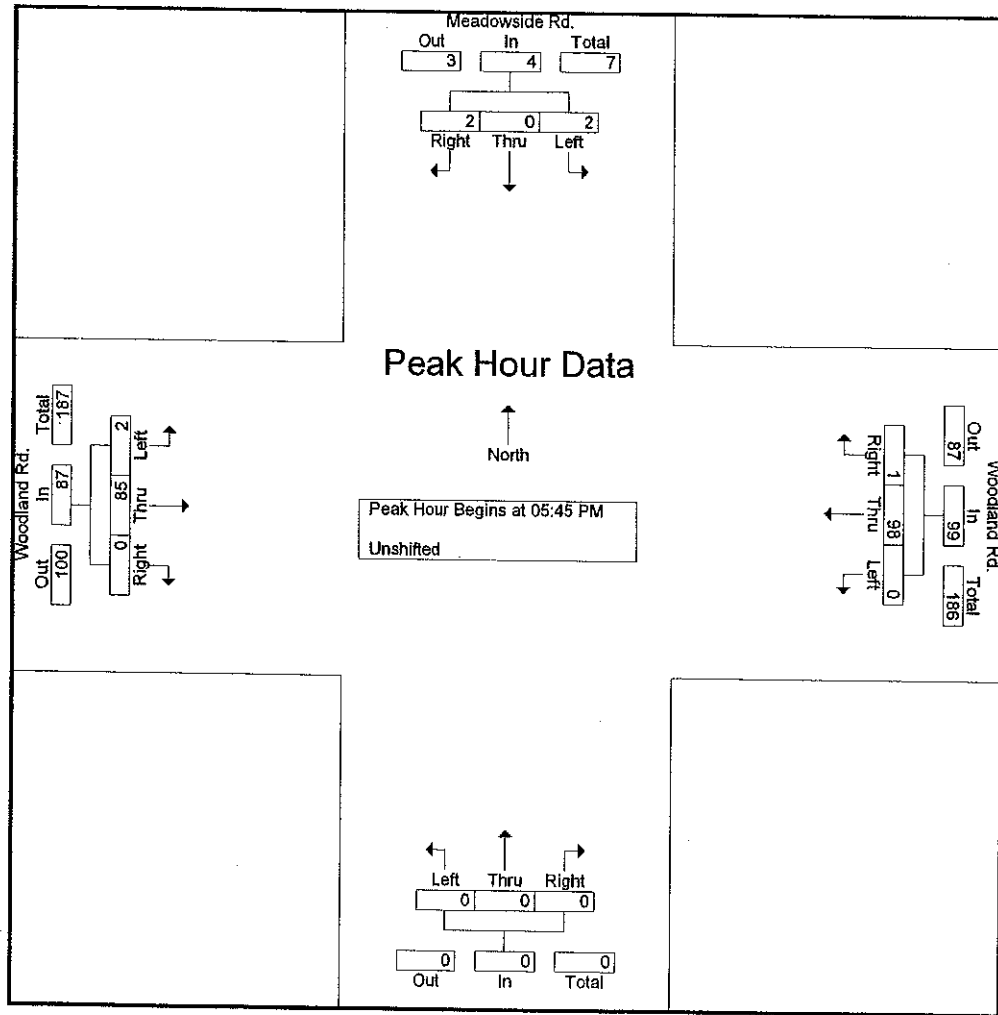

Counter: 17  
 Counted By: M. Bressler  
 Weather: clear  
 d As: PMCRWR

File Name : PMCRWR  
 Site Code : 00000011  
 Start Date : 5/20/2005  
 Page No : 1

Groups Printed- Unshifted

Start Time	Carlton Rd. Southbound					Westbound					Carlton Rd. Northbound					Woodland Rd. Eastbound					Exclu. Total	Inclu. Total	Int. Total
	Left	Thru	Right	Truck	App. Total	Left	Thru	Right	Truck	App. Total	Left	Thru	Right	Truck	App. Total	Left	Thru	Right	Truck	App. Total			
Factor	1.0	1.0	1.0	1.0		1.0	1.0	1.0	1.0		1.0	1.0	1.0	1.0		1.0	1.0	1.0	1.0				
04:00 PM	0	30	18	5	48	0	0	0	0	0	1	32	0	0	33	21	0	2	3	23			
04:15 PM	0	24	17	4	41	0	0	0	0	0	1	33	0	1	34	26	0	1	3	27	8	104	112
04:30 PM	0	22	15	1	37	0	0	0	0	0	2	37	0	1	39	19	0	2	0	21	8	102	110
04:45 PM	0	28	19	2	47	0	0	0	0	0	0	38	0	0	38	24	0	0	0	24	2	97	99
Total	0	104	69	12	173	0	0	0	0	0	4	140	0	2	144	90	0	5	6	95	20	412	432
05:00 PM	0	36	12	2	48	0	0	0	0	0	0	35	0	0	35	18	0	0	1	18	3	101	104
05:15 PM	0	36	23	0	59	0	0	0	0	0	1	36	0	0	37	16	0	0	0	16	0	112	112
05:30 PM	0	19	12	0	31	0	0	0	0	0	0	38	0	1	38	17	0	0	0	17	1	86	87
05:45 PM	0	28	26	2	54	0	0	0	0	0	0	30	0	0	30	16	0	1	0	17	2	101	103
Total	0	119	73	4	192	0	0	0	0	0	1	139	0	1	140	67	0	1	1	68	6	400	406
06:00 PM	0	27	28	2	55	0	0	0	0	0	2	32	0	1	34	19	0	0	1	19	4	108	112
06:15 PM	0	22	18	1	40	0	0	0	0	0	1	29	0	1	30	21	0	0	0	21	2	91	93
06:30 PM	0	21	23	0	44	0	0	0	0	0	0	27	0	1	27	24	0	0	0	24	1	95	96
06:45 PM	0	14	13	0	27	0	0	0	0	0	3	28	0	2	31	26	0	1	0	27	2	85	87
Total	0	84	82	3	166	0	0	0	0	0	6	116	0	5	122	90	0	1	1	91	9	379	388
07:00 PM	0	10	15	1	25	0	0	0	0	0	0	18	0	1	18	14	0	0	2	14	4	57	61
07:15 PM	0	13	9	1	22	0	0	0	0	0	0	20	0	1	20	12	0	0	0	12	2	54	56
07:30 PM	0	8	8	0	16	0	0	0	0	0	0	21	0	0	21	12	0	0	0	12	0	49	49
07:45 PM	0	13	7	0	20	0	0	0	0	0	0	27	0	0	27	15	0	0	0	15	0	62	62
Total	0	44	39	2	83	0	0	0	0	0	0	86	0	2	86	53	0	0	2	53	6	222	228
Grand Total	0	351	263	21	614	0	0	0	0	0	11	481	0	10	492	300	0	7	10	307	41	1413	1454
Apprch %	0	57.	42.			0	0	0			2.2	97.	0			97.	0	2.3					
Total %	0	24.	18.		43.5	0	0	0			0.8	34	0		34.8	21.	0	0.5		21.7	2.8	97.2	

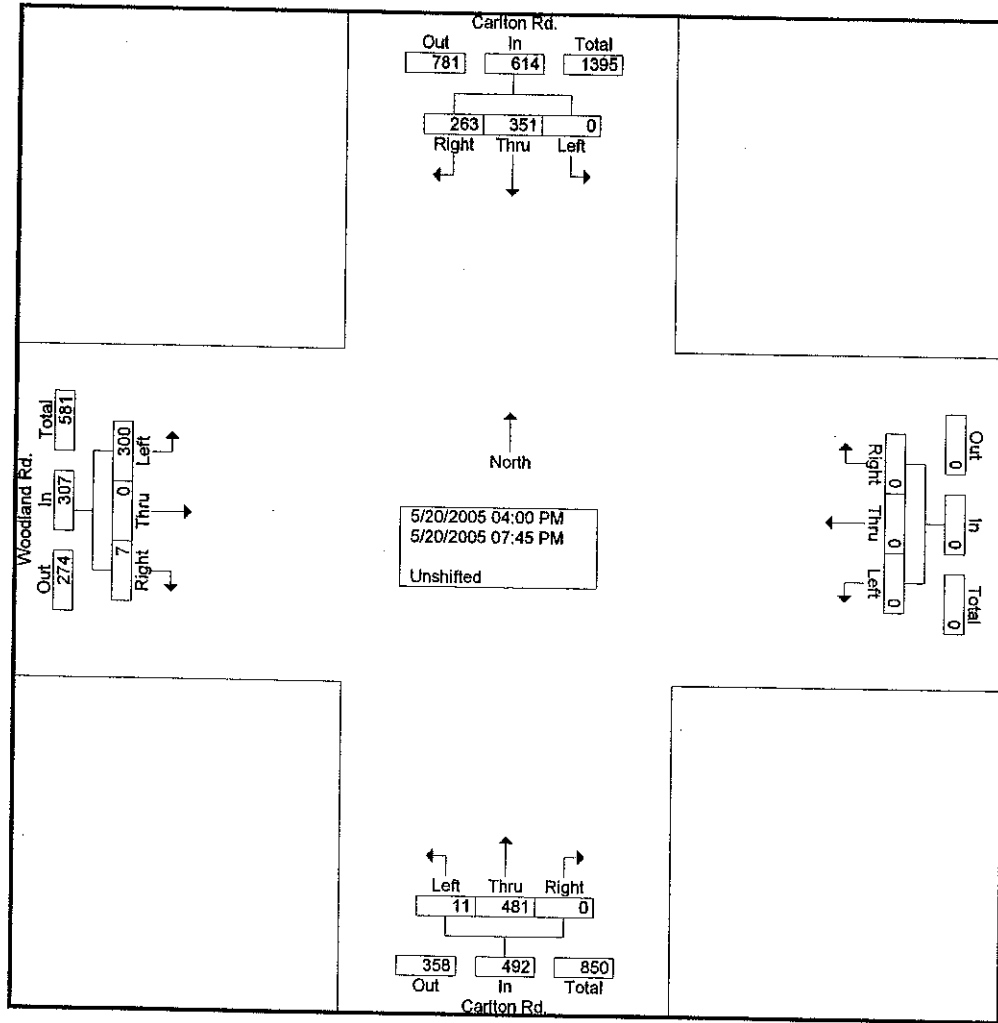

Start Time	Carlton Rd. Southbound				Westbound				Carlton Rd. Northbound				Woodland Rd. Eastbound				Int. Total
	Left	Thru	Right	App. Total	Left	Thru	Right	App. Total	Left	Thru	Right	App. Total	Left	Thru	Right	App. Total	
Peak Hour Analysis from 04:00 PM to 07:45 PM - Peak 1 of 1																	
Peak Hour for Entire Intersection Begins at 04:30 PM																	
04:30 PM	0	22	15	37	0	0	0	0	2	37	0	39	19	0	2	21	97
04:45 PM	0	28	19	47	0	0	0	0	0	38	0	38	24	0	0	24	109
05:00 PM	0	36	12	48	0	0	0	0	0	35	0	35	18	0	0	18	101
05:15 PM	0	36	23	59	0	0	0	0	1	36	0	37	16	0	0	16	112
Total Volume	0	122	69	191	0	0	0	0	3	146	0	149	77	0	2	79	419
% App. Total	0	63.9	36.1		0	0	0		2	98	0		97.5	0	2.5		
PIHF	.000	.847	.750	.809	.000	.000	.000	.000	.375	.961	.000	.955	.802	.000	.250	.823	.935

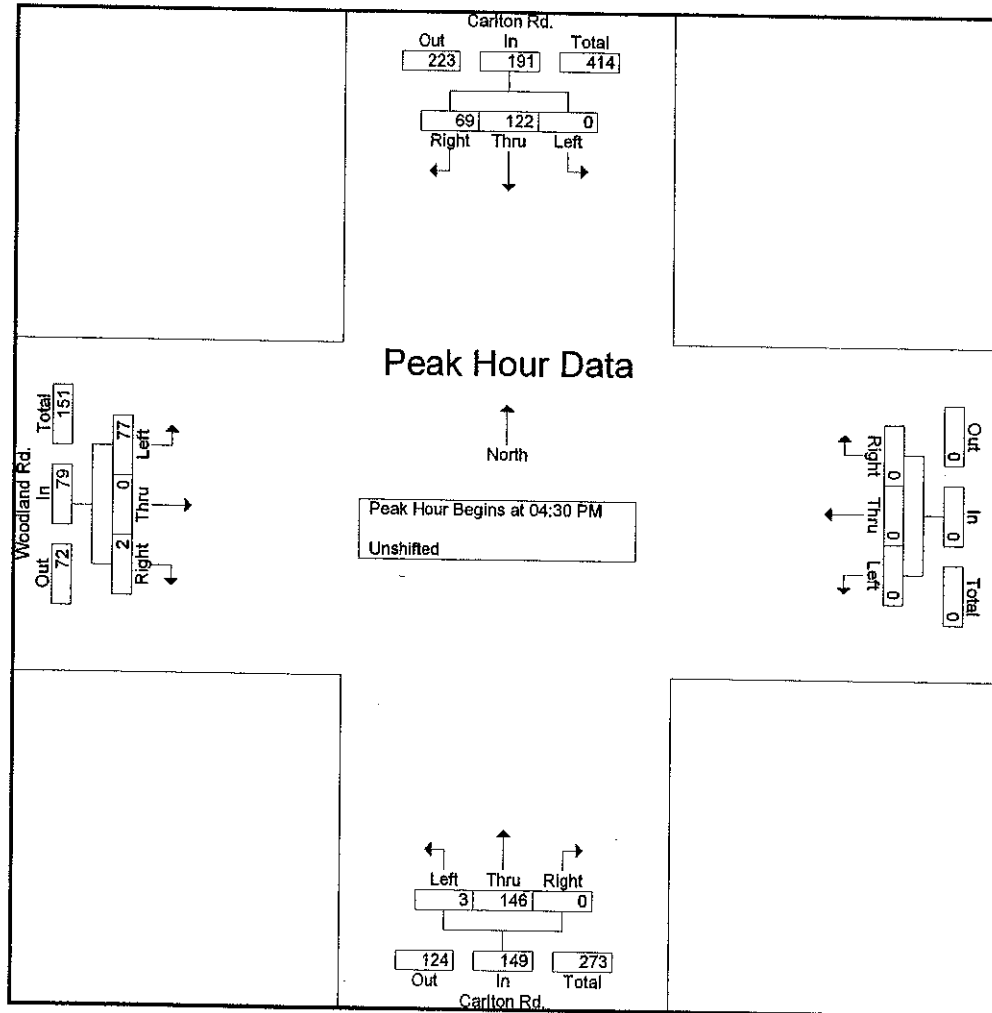

Groups Printed- Unshifted

Start Time	Resort Driveway Southbound					Route 940 Westbound					Carlton Road Northbound					Route 940 Eastbound					Exclu. Total	Inclu. Total	Int. Total
	Left	Thru	Right	Trucks	App. Total	Left	Thru	Right	Trucks	App. Total	Left	Thru	Right	Trucks	App. Total	Left	Thru	Right	Trucks	App. Total			
Factor	1.0	1.0	1.0	1.0		1.0	1.0	1.0	1.0		1.0	1.0	1.0	1.0		1.0	1.0	1.0	1.0				
04:00 PM	1	0	2	0	3	39	75	0	9	114	8	0	46	3	54	0	84	9	0	93	12	264	276
04:15 PM	0	1	1	0	2	33	87	1	2	121	9	0	44	3	53	0	113	10	1	123	6	299	305
04:30 PM	0	2	0	0	2	34	91	0	5	125	8	1	56	3	65	1	95	6	3	102	11	294	305
04:45 PM	0	3	2	0	5	37	91	0	2	128	5	0	45	1	50	0	94	9	0	103	3	286	289
Total	1	6	5	0	12	143	344	1	18	488	30	1	191	10	222	1	386	34	4	421	32	1143	1175
05:00 PM	2	1	0	0	3	39	86	0	3	125	8	1	48	1	57	2	86	9	3	97	7	282	289
05:15 PM	0	0	2	0	2	50	81	0	2	131	4	0	52	0	56	1	77	7	0	85	2	274	276
05:30 PM	0	1	0	0	1	28	100	0	1	128	5	3	54	0	62	0	74	8	1	82	2	273	275
05:45 PM	0	1	1	0	2	44	73	1	3	118	6	1	46	0	53	0	67	9	2	76	5	249	254
Total	2	3	3	0	8	161	340	1	9	502	23	5	200	1	228	3	304	33	6	340	16	1078	1094
06:00 PM	1	3	0	0	4	50	59	0	1	109	3	1	42	0	46	0	73	8	0	81	1	240	241
06:15 PM	0	0	2	0	2	36	60	0	1	96	6	0	46	1	52	0	76	4	0	80	2	230	232
06:30 PM	0	2	0	0	2	34	63	0	1	97	6	0	45	1	51	1	62	5	0	68	2	218	220
06:45 PM	0	0	2	0	2	24	58	0	0	82	11	1	32	2	44	0	63	2	1	65	3	193	196
Total	1	5	4	0	10	144	240	0	3	384	26	2	165	4	193	1	274	19	1	294	8	881	889
07:00 PM	0	0	0	0	0	19	59	0	1	78	4	0	30	1	34	0	52	5	0	57	2	169	171
07:15 PM	0	0	1	0	1	20	55	0	0	75	5	0	24	0	29	0	41	3	0	44	0	149	149
07:30 PM	0	0	0	0	0	17	26	0	0	43	2	0	31	0	33	0	42	1	0	43	0	119	119
07:45 PM	0	0	0	0	0	17	56	0	1	73	6	1	40	0	47	0	55	4	0	59	1	179	180
Total	0	0	1	0	1	73	196	0	2	269	17	1	125	1	143	0	190	13	0	203	3	616	619
Grand Total	4	14	13	0	31	521	1120	2	32	1643	96	9	681	16	786	5	1154	99	11	1258	59	3718	3777
Apprch %	12.	45.	41.			31.	68.	0.1			12.	1.1	86.			0.4	91.	7.9					
Total %	0.1	0.4	0.3		0.8	14	30.	0.1		44.2	2.6	0.2	18.		21.1	0.1	31	2.7		33.8	1.6	98.4	

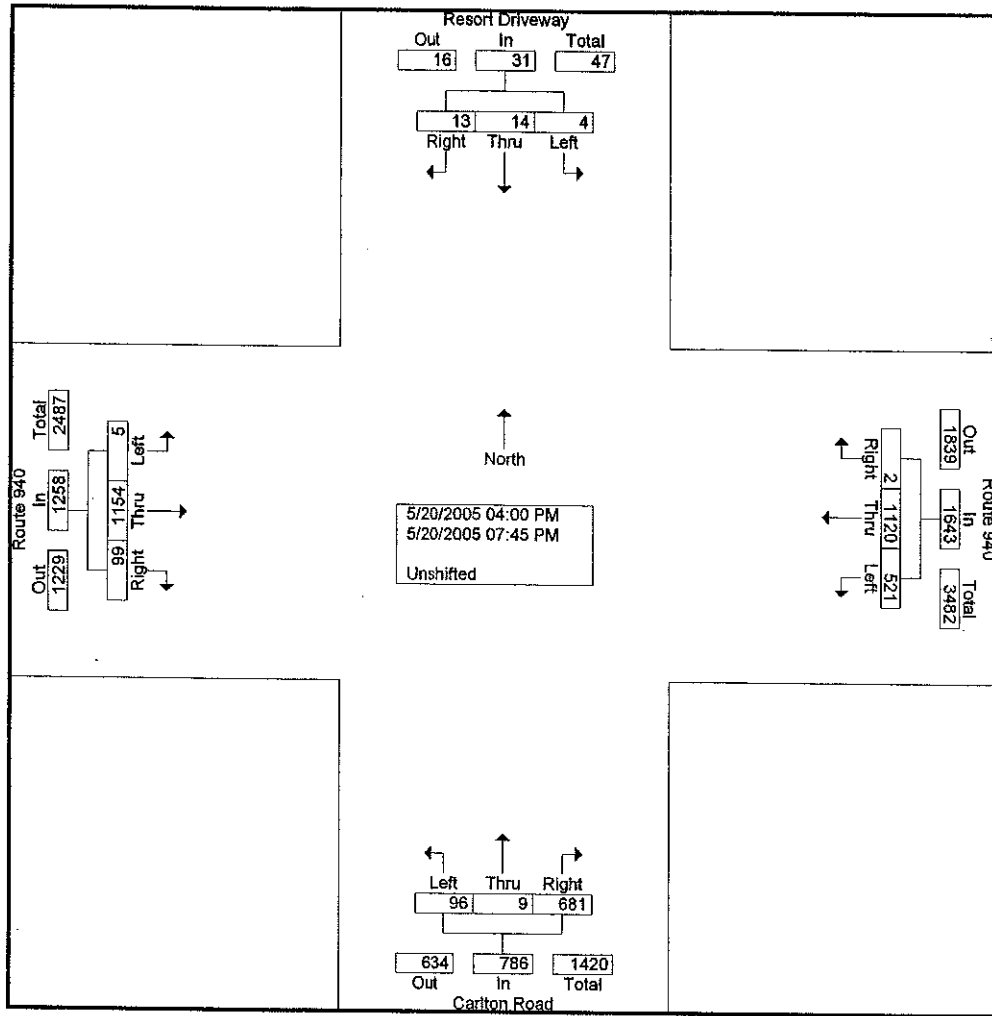



Start Time	Resort Driveway Southbound				Route 940 Westbound				Carlton Road Northbound				Route 940 Eastbound				Int. Total
	Left	Thru	Right	App. Total	Left	Thru	Right	App. Total	Left	Thru	Right	App. Total	Left	Thru	Right	App. Total	
Peak Hour Analysis From 04:00 PM to 07:45 PM - Peak 1 of 1																	
Peak Hour for Entire Intersection Begins at 04:15 PM																	
04:15 PM	0	1	1	2	33	87	1	121	9	0	44	53	0	113	10	123	299
04:30 PM	0	2	0	2	34	91	0	125	8	1	56	65	1	95	6	102	294
04:45 PM	0	3	2	5	37	91	0	128	5	0	45	50	0	94	9	103	286
05:00 PM	2	1	0	3	39	86	0	125	8	1	48	57	2	86	9	97	282
Total Volume	2	7	3	12	143	355	1	499	30	2	193	225	3	388	34	425	1161
% App. Total	16.7	58.3	25		28.7	71.1	0.2		13.3	0.9	85.8		0.7	91.3	8		
PIIF	.250	.583	.375	.600	.917	.975	.250	.975	.833	.500	.862	.865	.375	.858	.850	.864	.971

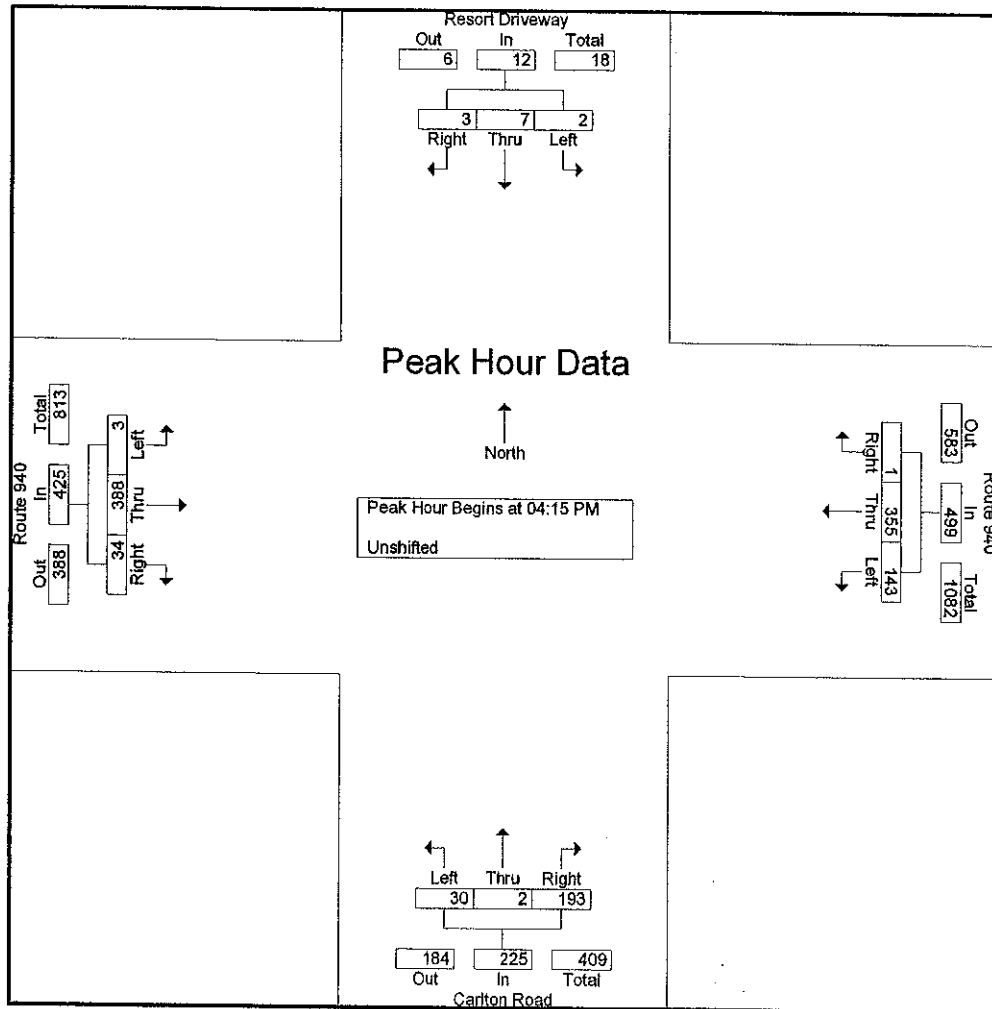

Counter: 30  
 Counted By: S. Natale  
 Weather: clear  
 \As: PM390940

File Name : PM390940  
 Site Code : 00000000  
 Start Date : 5/20/2005  
 Page No : 1

Groups Printed- Unshifted

Start Time	Route 390 Southbound					Route 940 Westbound					Northbound					Route 940 Eastbound					Exclu. Total	Inclu. Total	Int. Total
	Left	Thru	Right	Truck	App. Total	Left	Thru	Right	Truck	App. Total	Left	Thru	Right	Truck	App. Total	Left	Thru	Right	Truck	App. Total			
Factor	1.0	1.0	1.0	1.0		1.0	1.0	1.0	1.0		1.0	1.0	1.0	1.0		1.0	1.0	1.0	1.0				
04:00 PM	4	0	48	4	52	0	38	4	3	42	0	0	0	0	0	62	31	0	0	93	7	187	194
04:15 PM	2	0	48	2	50	0	39	4	0	43	0	0	0	0	0	74	40	0	4	114	6	207	213
04:30 PM	1	0	59	4	60	0	36	2	1	38	0	0	0	0	0	77	60	0	4	137	9	235	244
04:45 PM	3	0	54	1	57	0	40	3	1	43	0	0	0	0	0	90	31	0	2	121	4	221	225
Total	10	0	209	11	219	0	153	13	5	166	0	0	0	0	0	303	162	0	10	465	26	850	876
05:00 PM	1	0	70	3	71	0	45	2	0	47	0	0	0	0	0	77	42	0	3	119	6	237	243
05:15 PM	0	0	86	4	86	0	44	2	0	46	0	0	0	0	0	66	45	0	0	111	4	243	247
05:30 PM	2	0	50	0	52	0	47	2	0	49	0	0	0	0	0	78	31	0	2	109	2	210	212
05:45 PM	3	0	55	5	58	0	33	1	0	34	0	0	0	0	0	71	22	0	2	93	7	185	192
Total	6	0	261	12	267	0	169	7	0	176	0	0	0	0	0	292	140	0	7	432	19	875	894
06:00 PM	1	0	80	1	81	0	31	5	0	36	0	0	0	0	0	81	34	0	2	115	3	232	235
06:15 PM	1	0	48	0	49	0	41	1	3	42	0	0	0	0	0	74	44	0	1	118	4	209	213
06:30 PM	1	0	62	0	63	0	32	4	0	36	0	0	0	0	0	64	32	0	1	96	1	195	196
06:45 PM	1	0	43	0	44	0	29	4	0	33	0	0	0	0	0	73	18	0	3	91	3	168	171
Total	4	0	233	1	237	0	133	14	3	147	0	0	0	0	0	292	128	0	7	420	11	804	815
07:00 PM	4	0	42	1	46	0	29	4	0	33	0	0	0	0	0	48	28	0	3	76	4	155	159
07:15 PM	1	0	46	0	47	0	25	1	0	26	0	0	0	0	0	51	24	0	1	75	1	148	149
07:30 PM	4	0	23	0	27	0	18	5	0	23	0	0	0	0	0	53	19	0	1	72	1	122	123
07:45 PM	3	0	36	3	39	0	31	1	0	32	0	0	0	0	0	61	29	0	0	90	3	161	164
Total	12	0	147	4	159	0	103	11	0	114	0	0	0	0	0	213	100	0	5	313	9	586	595
Grand Total	32	0	850	28	882	0	558	45	8	603	0	0	0	0	0	1100	530	0	29	1630	65	3115	3180
Apprch %	3.6	0	96.4			0	92.5	7.5			0	0	0			67.5	32.5	0					
Total %	1	0	27.3		28.3	0	17.9	1.4		19.4	0	0	0		0	35.3	17	0		52.3	2	98	

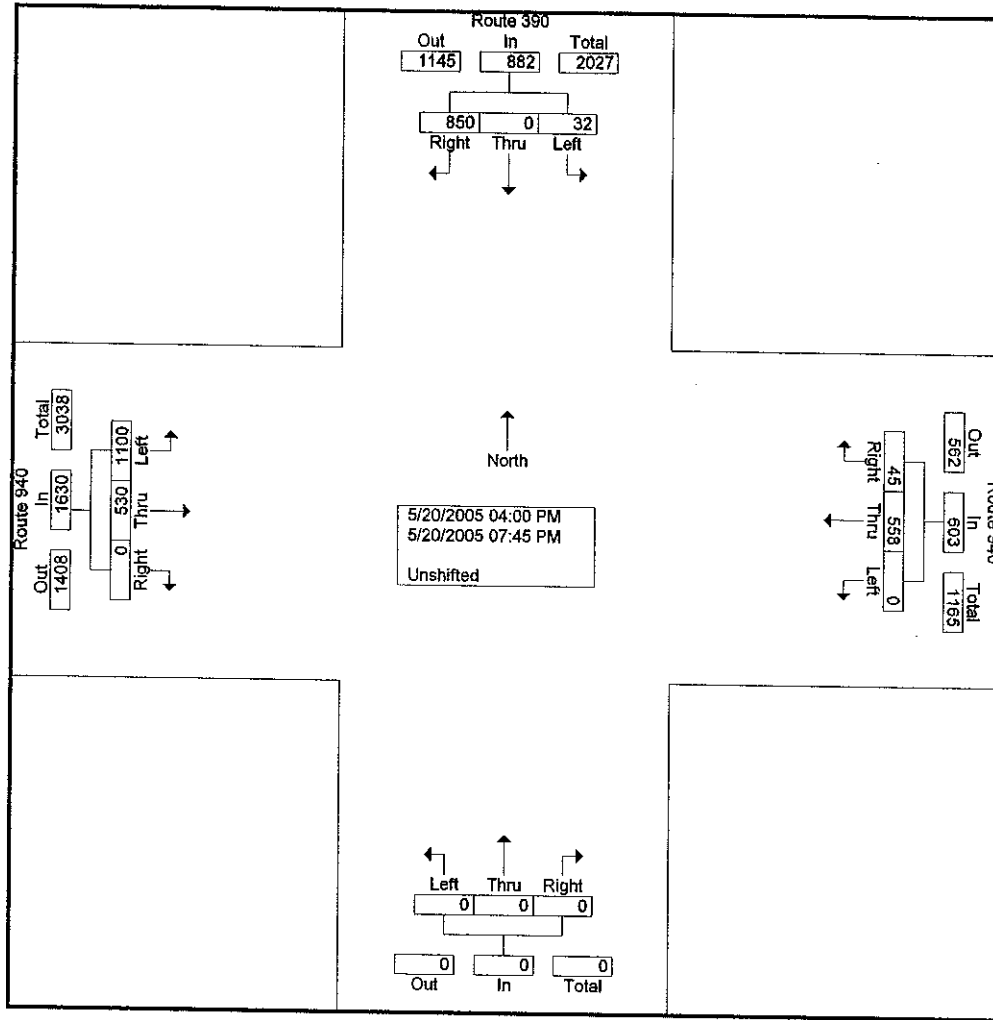

Start Time	Route 390 Southbound				Route 940 Westbound				Northbound				Route 940 Eastbound				Int. Total
	Left	Thru	Right	App. Total	Left	Thru	Right	App. Total	Left	Thru	Right	App. Total	Left	Thru	Right	App. Total	
Peak Hour Analysis From 04:00 PM to 07:45 PM - Peak 1 of 1																	
Peak Hour for Entire Intersection Begins at 04:30 PM																	
04:30 PM	1	0	59	60	0	36	2	38	0	0	0	0	77	60	0	137	235
04:45 PM	3	0	54	57	0	40	3	43	0	0	0	0	90	31	0	121	221
05:00 PM	1	0	70	71	0	45	2	47	0	0	0	0	77	42	0	119	237
05:15 PM	0	0	86	86	0	44	2	46	0	0	0	0	66	45	0	111	243
Total Volume	5	0	269	274	0	165	9	174	0	0	0	0	310	178	0	488	936
% App. Total	1.8	0	98.2		0	94.8	5.2		0	0	0		63.5	36.5	0		936
PHF	.417	.000	.782	.797	.000	.917	.750	.926	.000	.000	.000	.000	.861	.742	.000	.891	.963

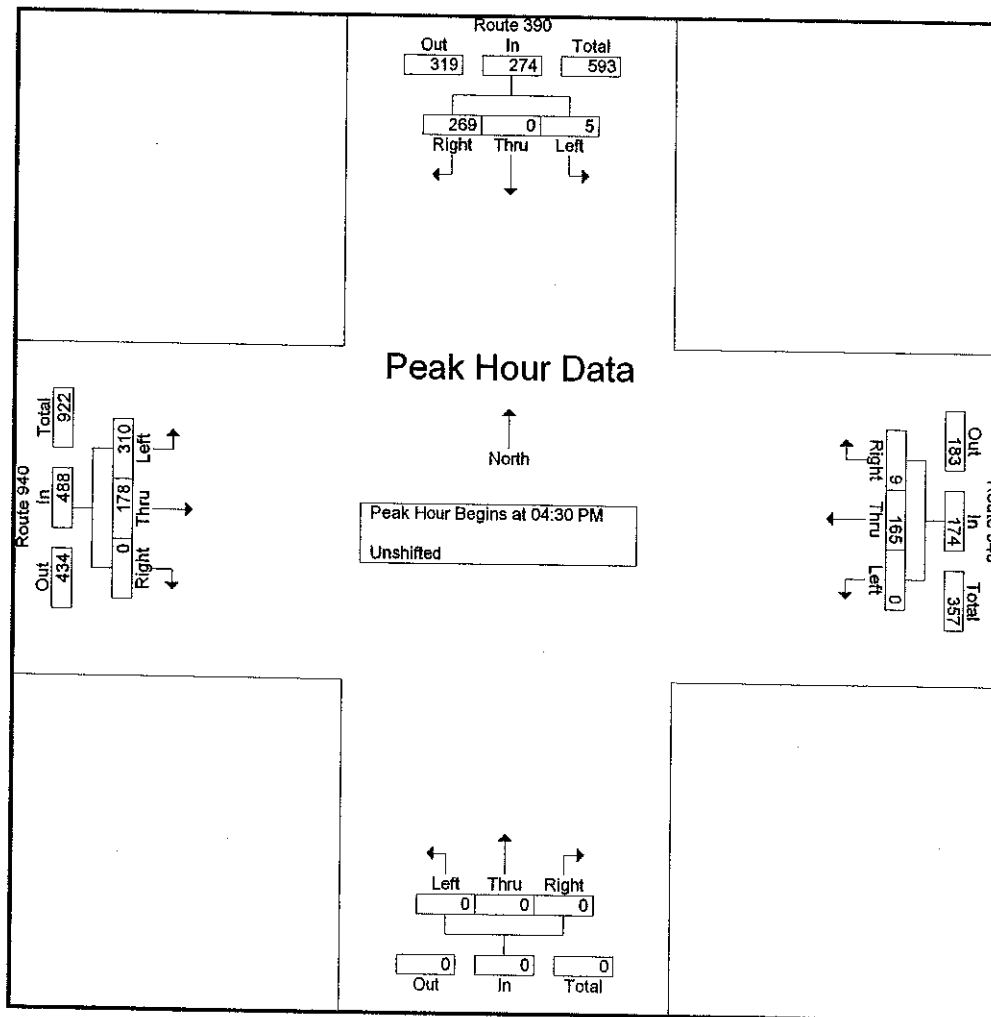

Groups Printed- Unshifted

Start Time	Route 191 Southbound					Route 940 Westbound					Red Rock Road Northbound					Route 940 Eastbound					Excl. Total	Incl. Total	Int. Total
	Left	Thru	Right	Trucks	App. Total	Left	Thru	Right	Trucks	App. Total	Left	Thru	Right	Trucks	App. Total	Left	Thru	Right	Trucks	App. Total			
04:00 PM	2	3	0	0	5	6	38	1	0	45	23	0	3	0	26	1	47	23	2	71	2	147	149
04:15 PM	1	2	0	0	3	7	49	1	1	57	12	2	3	0	17	1	55	19	0	75	1	152	153
04:30 PM	1	3	1	0	5	11	45	1	1	57	14	1	10	0	25	1	41	18	2	60	3	147	150
04:45 PM	0	2	1	0	3	11	33	1	0	45	18	1	3	1	22	2	57	29	2	88	3	158	161
Total	4	10	2	0	16	35	165	4	2	204	67	4	19	1	90	5	200	89	6	294	9	604	613
05:00 PM	2	0	3	0	5	6	37	0	1	43	22	0	4	0	26	4	43	18	1	65	2	139	141
05:15 PM	0	2	1	0	3	7	31	1	0	39	25	3	9	0	37	0	42	33	0	75	0	154	154
05:30 PM	1	2	0	0	3	3	28	1	0	32	9	1	14	0	24	1	58	21	0	80	0	139	139
05:45 PM	0	2	0	0	2	1	26	0	0	27	7	2	6	1	15	1	34	19	1	54	2	98	100
Total	3	6	4	0	13	17	122	2	1	141	63	6	33	1	102	6	177	91	2	274	4	530	534
06:00 PM	1	1	1	0	3	3	28	0	0	31	17	2	4	0	23	1	31	12	1	44	1	101	102
06:15 PM	2	4	1	0	7	5	35	1	0	41	6	0	2	1	8	2	40	13	3	55	4	111	115
06:30 PM	0	0	0	0	0	8	23	1	0	32	15	1	7	1	23	0	24	26	0	50	1	105	106
06:45 PM	1	2	0	0	3	4	27	0	0	31	17	2	3	0	22	1	29	15	1	45	1	101	102
Total	4	7	2	0	13	20	113	2	0	135	55	5	16	2	76	4	124	66	5	194	7	418	425
07:00 PM	1	4	0	0	5	2	28	2	0	32	8	0	3	1	11	0	32	14	0	46	1	94	95
07:15 PM	1	3	0	0	4	3	17	0	0	20	5	0	2	0	7	0	26	10	0	36	0	67	67
07:30 PM	0	1	1	0	2	3	20	2	0	25	4	2	2	0	8	0	19	7	0	26	0	61	61
07:45 PM	2	0	1	0	3	3	23	1	0	27	8	0	6	0	14	0	24	7	0	31	0	75	75
Total	4	8	2	0	14	11	88	5	0	104	25	2	13	1	40	0	101	38	0	139	1	297	298
nd Total	15	31	10	0	56	83	488	13	3	584	210	17	81	5	308	15	602	284	13	901	21	1849	1870
prch %	26.8	55.4	17.9			14.2	83.6	2.2			68.2	5.5	26.3			1.7	66.8	31.5					
Total %	0.8	1.7	0.5		3	4.5	26.4	0.7		31.6	11.4	0.9	4.4		16.7	0.8	32.6	15.4		48.7	1.1	98.9	

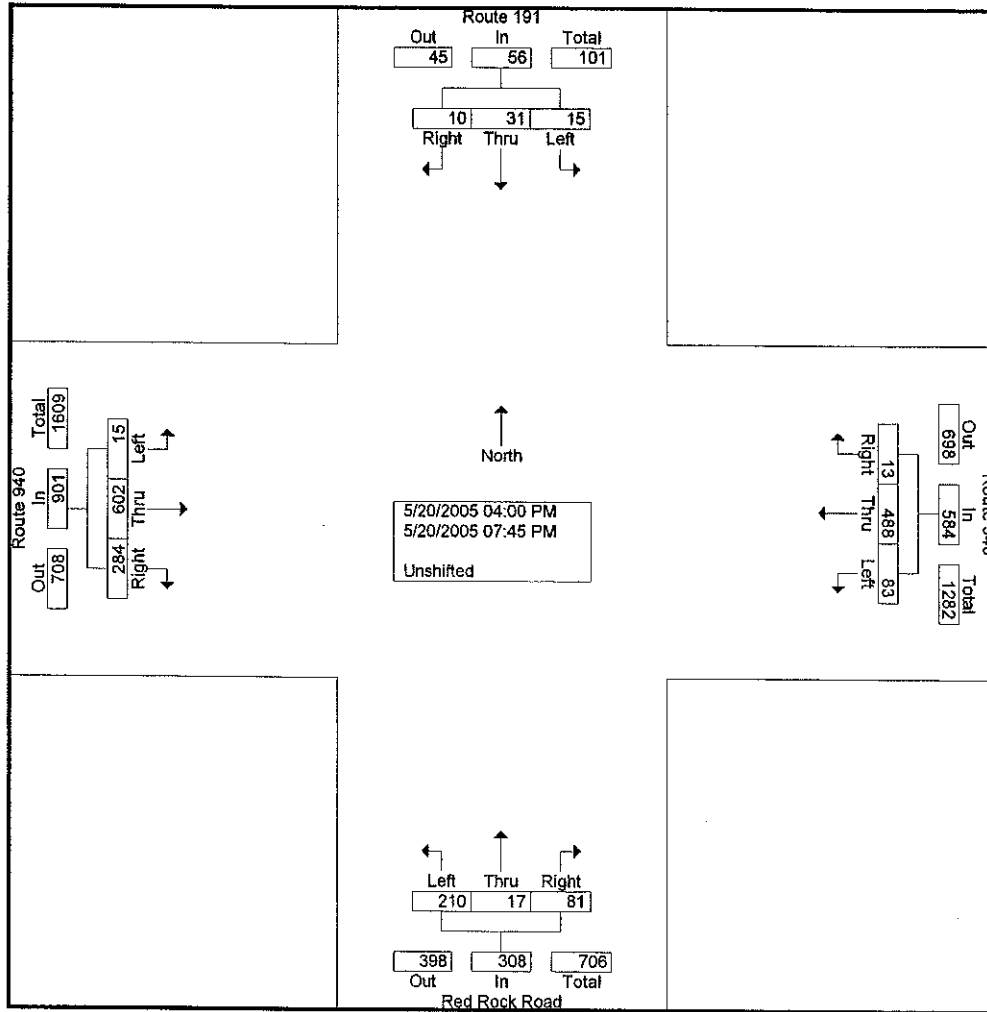

Start Time	Route 191 Southbound				Route 940 Westbound				Red Rock Road Northbound				Route 940 Eastbound				Int. Total
	Left	Thru	Right	App. Total	Left	Thru	Right	App. Total	Left	Thru	Right	App. Total	Left	Thru	Right	App. Total	
Peak Hour Analysis From 04:00 PM to 07:45 PM - Peak 1 of 1																	
Peak Hour for Entire Intersection Begins at 04:00 PM																	
04:00 PM	2	3	0	5	6	38	1	45	23	0	3	26	1	47	23	71	147
04:15 PM	1	2	0	3	7	49	1	57	12	2	3	17	1	55	19	75	152
04:30 PM	1	3	1	5	11	45	1	57	14	1	10	25	1	41	18	60	147
04:45 PM	0	2	1	3	11	33	1	45	18	1	3	22	2	57	29	88	158
Total Volume	4	10	2	16	35	165	4	204	67	4	19	90	5	200	89	294	604
% App. Total	25	62.5	12.5		17.2	80.9	2		74.4	4.4	21.1		1.7	68	30.3		
PHF	.500	.833	.500	.800	.795	.842	1.000	.895	.728	.500	.475	.865	.625	.877	.767	.835	.956

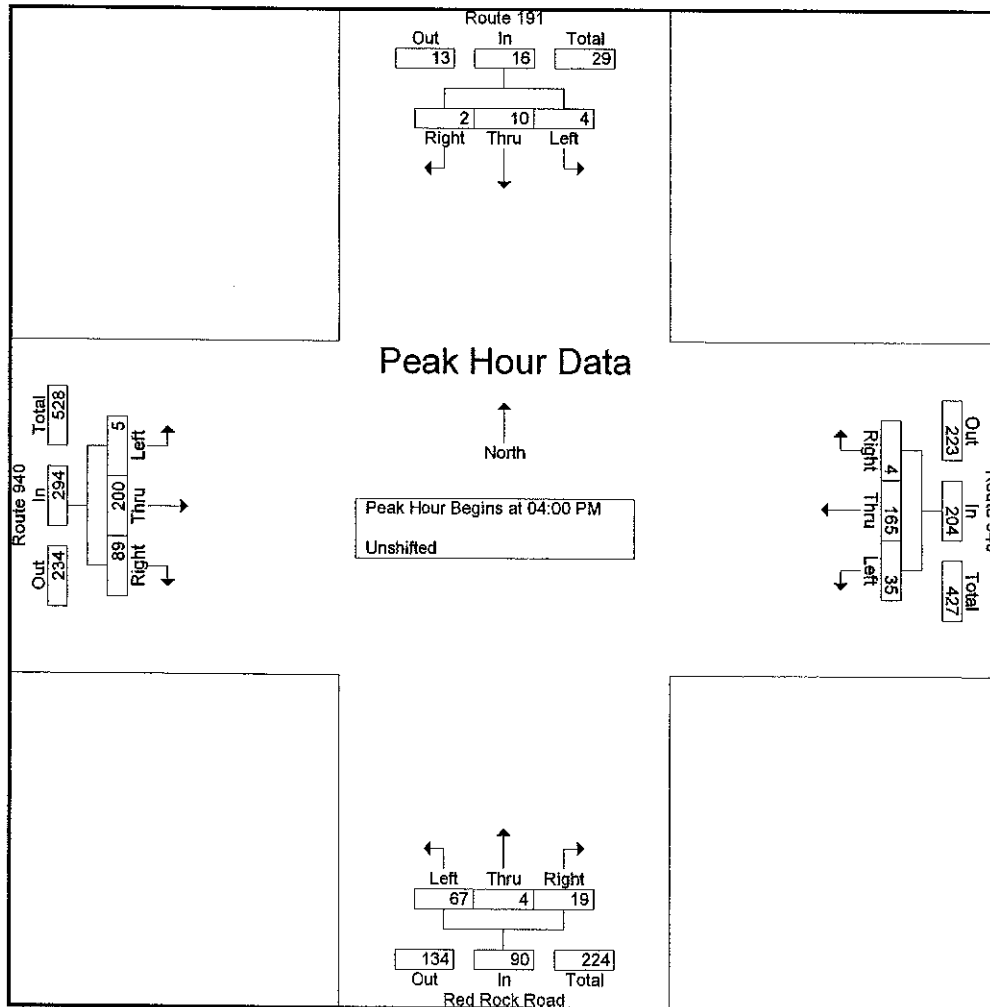

Counter: 16  
 Counted By: M. Rosen  
 Weather: clear  
 As: SA314611

File Name : SA3146112  
 Site Code : 00000000  
 Start Date : 5/21/2005  
 Page No : 1

Groups Printed- Unshifted

Start Time	Route 611 Southbound					Route 314 Westbound					Route 611 Northbound					Eastbound					Exclu. Total	Inclu. Total	Int. Total
	Left	Thru	Right	Truck	App. Total	Left	Thru	Right	Truck	App. Total	Left	Thru	Right	Truck	App. Total	Left	Thru	Right	Truck	App. Total			
Factor	1.0	1.0	1.0	1.0		1.0	1.0	1.0	1.0		1.0	1.0	1.0	1.0		1.0	1.0	1.0	1.0				
03:00 PM	15	144	0	1	159	19	0	4	0	23	0	167	29	0	196	0	0	0	0	0			
03:15 PM	10	161	0	3	171	27	0	4	0	31	0	179	34	3	213	0	0	0	0	0	1	378	379
03:30 PM	10	133	0	3	143	18	0	11	1	29	0	167	38	2	205	0	0	0	0	0	6	415	421
03:45 PM	11	160	0	0	171	21	0	10	1	31	0	178	47	2	225	0	0	0	0	0	6	377	383
Total	46	598	0	7	644	85	0	29	2	114	0	691	148	7	839	0	0	0	0	0	16	1597	1613
04:00 PM	7	147	5	1	159	28	0	7	1	35	0	174	33	0	207	0	0	0	0	0	2	401	403
04:15 PM	11	121	0	0	132	36	0	4	2	40	0	164	32	3	196	0	0	0	0	0	5	368	373
04:30 PM	10	146	0	1	156	20	0	7	1	27	3	172	21	0	196	0	0	0	0	0	2	379	381
04:45 PM	16	118	0	0	134	29	0	6	0	35	0	161	28	1	189	0	0	0	0	0	1	358	359
Total	44	532	5	2	581	113	0	24	4	137	3	671	114	4	788	0	0	0	0	0	10	1506	1516
05:00 PM	9	129	0	0	138	29	0	8	1	37	0	170	48	4	218	0	0	0	0	0	5	393	398
05:15 PM	6	110	0	0	116	21	0	10	1	31	0	135	30	2	165	0	0	0	0	0	3	312	315
05:30 PM	6	120	0	0	126	28	0	6	0	34	0	143	29	0	172	0	0	0	0	0	0	332	332
05:45 PM	9	122	0	0	131	18	0	7	0	25	0	147	23	0	170	0	0	0	0	0	0	326	326
Total	30	481	0	0	511	96	0	31	2	127	0	595	130	6	725	0	0	0	0	0	8	1363	1371
06:00 PM	11	112	0	0	123	35	0	4	1	39	5	151	22	0	178	0	0	0	0	0	1	340	341
06:15 PM	13	107	0	0	120	26	0	8	1	34	0	128	23	0	151	0	0	0	0	0	1	305	306
06:30 PM	6	94	0	0	100	28	0	6	1	34	0	156	33	2	189	0	0	0	0	0	3	323	326
06:45 PM	6	109	0	0	115	11	0	4	0	15	0	123	36	0	159	0	0	0	0	0	0	289	289
Total	36	422	0	0	458	100	0	22	3	122	5	558	114	2	677	0	0	0	0	0	5	1257	1262
Grand Total	156	2033	5	9	2194	394	0	106	11	500	8	2515	506	19	3029	0	0	0	0	0	39	5723	5762
Apprch %	7.1	92.7	0.2			78.8	0	21.2			0.3	83.7	16.7			0	0	0					
Total %	2.7	35.5	0.1		38.3	6.9	0	1.9		8.7	0.1	43.9	8.8		52.9	0	0	0			0.7	99.3	



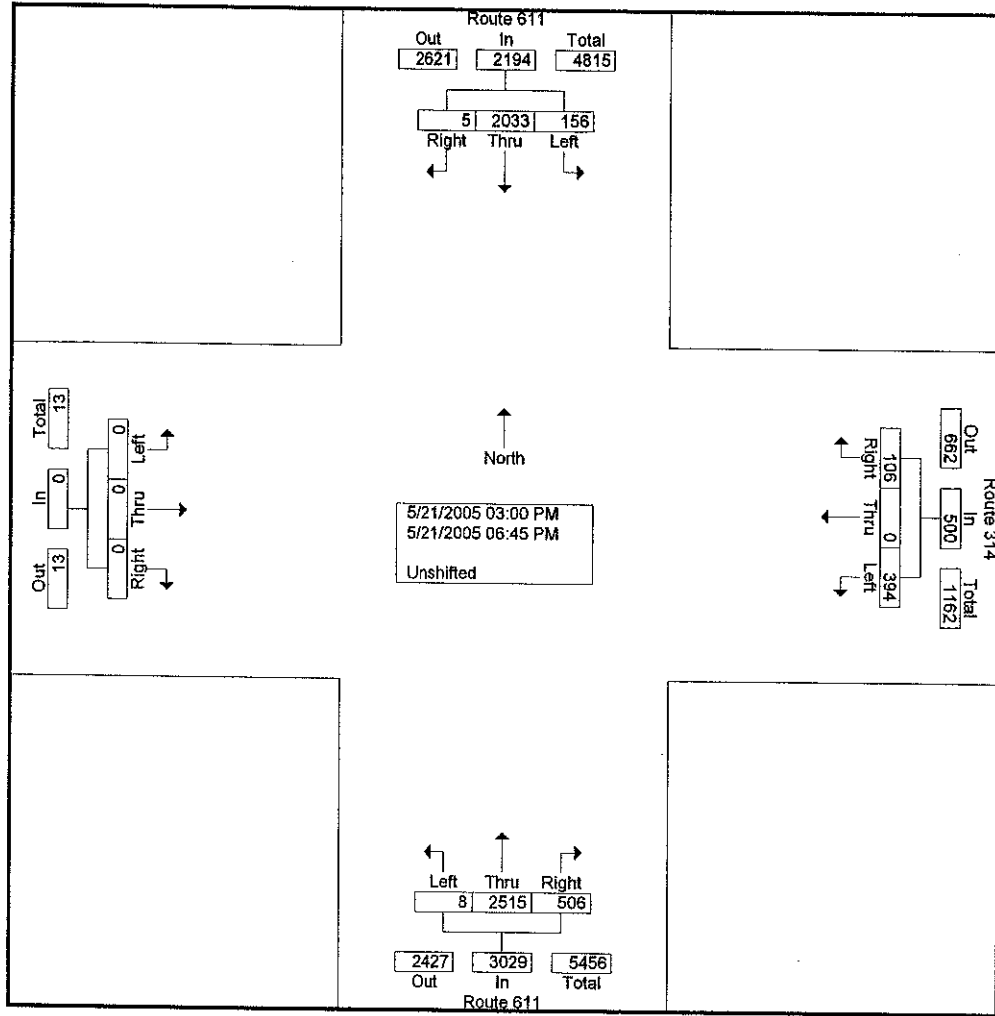

Start Time	Route 611 Southbound				Route 314 Westbound				Route 611 Northbound				Eastbound				Int. Total
	Left	Thru	Right	App. Total	Left	Thru	Right	App. Total	Left	Thru	Right	App. Total	Left	Thru	Right	App. Total	
Peak Hour Analysis From 03:00 PM to 06:45 PM - Peak 1 of 1																	
Peak Hour for Entire Intersection Begins at 03:15 PM																	
03:15 PM	10	161	0	171	27	0	4	31	0	179	34	213	0	0	0	0	415
03:30 PM	10	133	0	143	18	0	11	29	0	167	38	205	0	0	0	0	377
03:45 PM	11	160	0	171	21	0	10	31	0	178	47	225	0	0	0	0	427
04:00 PM	7	147	5	159	28	0	7	35	0	174	33	207	0	0	0	0	401
Total Volume	38	601	5	644	94	0	32	126	0	698	152	850	0	0	0	0	1620
% App. Total	5.9	93.3	0.8		74.6	0	25.4		0	82.1	17.9		0	0	0		
PHF	.864	.933	.250	.942	.839	.000	.727	.900	.000	.975	.809	.944	.000	.000	.000	.000	.948

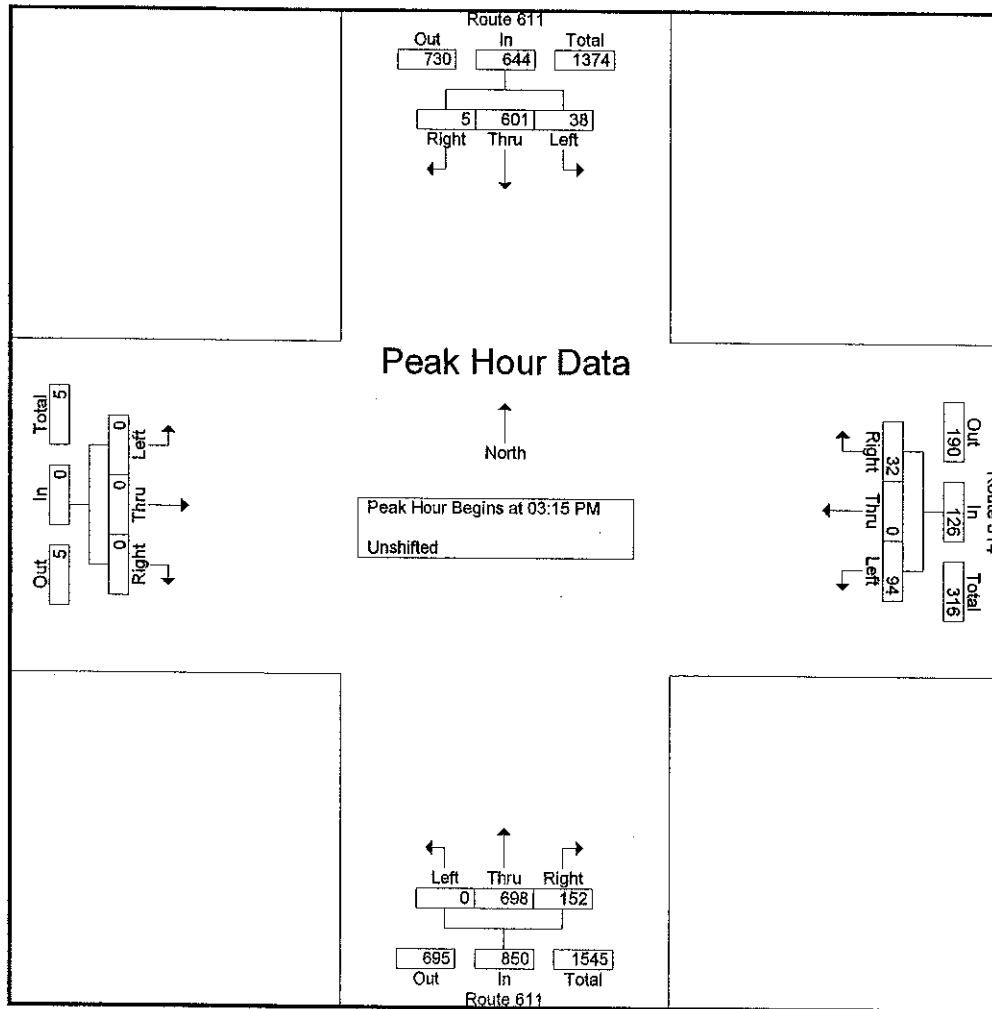

Counter: 3  
 Counted By: D. Bitterlich  
 Weather: clear  
 d As: SA611314

File Name : SA611314  
 Site Code : 00000002  
 Start Date : 5/21/2005  
 Page No : 1

Groups Printed- Unshifted

Start Time	Route 611 Southbound					Driveway Westbound					Route 611 Northbound					Route 314 Eastbound					Exclu. Total	Inclu. Total	Int. Total
	Left	Thru	Right	Truck	App. Total	Left	Thru	Right	Truck	App. Total	Left	Thru	Right	Truck	App. Total	Left	Thru	Right	Truck	App. Total			
Factor	1.0	1.0	1.0	1.0		1.0	1.0	1.0	1.0		1.0	1.0	1.0	1.0		1.0	1.0	1.0	1.0				
03:00 PM	0	145	4	1	149	0	0	0	0	0	27	153	0	1	180	3	0	24	0	27	2	356	358
03:15 PM	0	142	2	1	144	0	0	0	0	0	20	142	0	1	162	4	0	26	4	30	6	336	342
03:30 PM	0	134	4	4	138	0	0	0	0	0	38	144	0	2	182	4	0	18	0	22	6	342	348
03:45 PM	1	143	6	1	150	0	0	0	0	0	30	148	0	2	178	6	0	28	0	34	3	362	365
Total	1	564	16	7	581	0	0	0	0	0	115	587	0	6	702	17	0	96	4	113	17	1396	1413
04:00 PM	0	144	5	2	149	0	0	0	0	0	32	120	0	0	152	2	0	21	0	23	2	324	326
04:15 PM	0	130	2	0	132	0	0	0	0	0	34	152	0	0	186	3	0	9	0	12	0	330	330
04:30 PM	0	139	4	0	143	0	0	0	0	0	26	139	0	0	165	4	0	23	1	27	1	335	336
04:45 PM	0	128	5	0	133	0	0	0	0	0	24	166	0	2	190	4	0	21	1	25	3	348	351
Total	0	541	16	2	557	0	0	0	0	0	116	577	0	2	693	13	0	74	2	87	6	1337	1343
05:00 PM	0	125	5	0	130	0	0	0	0	0	18	143	0	3	161	5	0	21	0	26	3	317	320
05:15 PM	1	127	3	1	131	0	0	0	0	0	29	168	0	3	197	3	0	22	0	25	4	353	357
05:30 PM	2	119	4	1	125	0	0	0	0	0	24	116	0	1	140	6	0	12	0	18	2	283	285
05:45 PM	0	114	6	0	120	0	0	0	0	0	22	123	0	0	145	2	0	17	0	19	0	284	284
Total	3	485	18	2	506	0	0	0	0	0	93	550	0	7	643	16	0	72	0	88	9	1237	1246
06:00 PM	0	112	7	0	119	0	0	0	0	0	15	125	1	0	141	3	0	13	0	16	0	276	276
06:15 PM	1	123	3	0	127	1	0	0	0	1	16	134	0	2	150	8	0	12	0	20	2	298	300
06:30 PM	1	92	7	0	100	0	0	0	0	0	26	127	0	1	153	3	0	9	0	12	1	265	266
06:45 PM	0	105	4	1	109	0	0	0	0	0	11	119	0	0	130	3	0	14	0	17	1	256	257
Total	2	432	21	1	455	1	0	0	0	1	68	505	1	3	574	17	0	48	0	65	4	1095	1099
Grand Total	6	2022	71	12	2099	1	0	0	0	1	392	2219	1	18	2612	63	0	290	6	353	36	5065	5101
Approch %	0.3	96.3	3.4			100	0	0			15	85	0			17.8	0	82.2					
Total %	0.1	39.9	1.4		41.4	0	0	0		0	7.7	43.8	0		51.6	1.2	0	5.7		7	0.7	99.3	

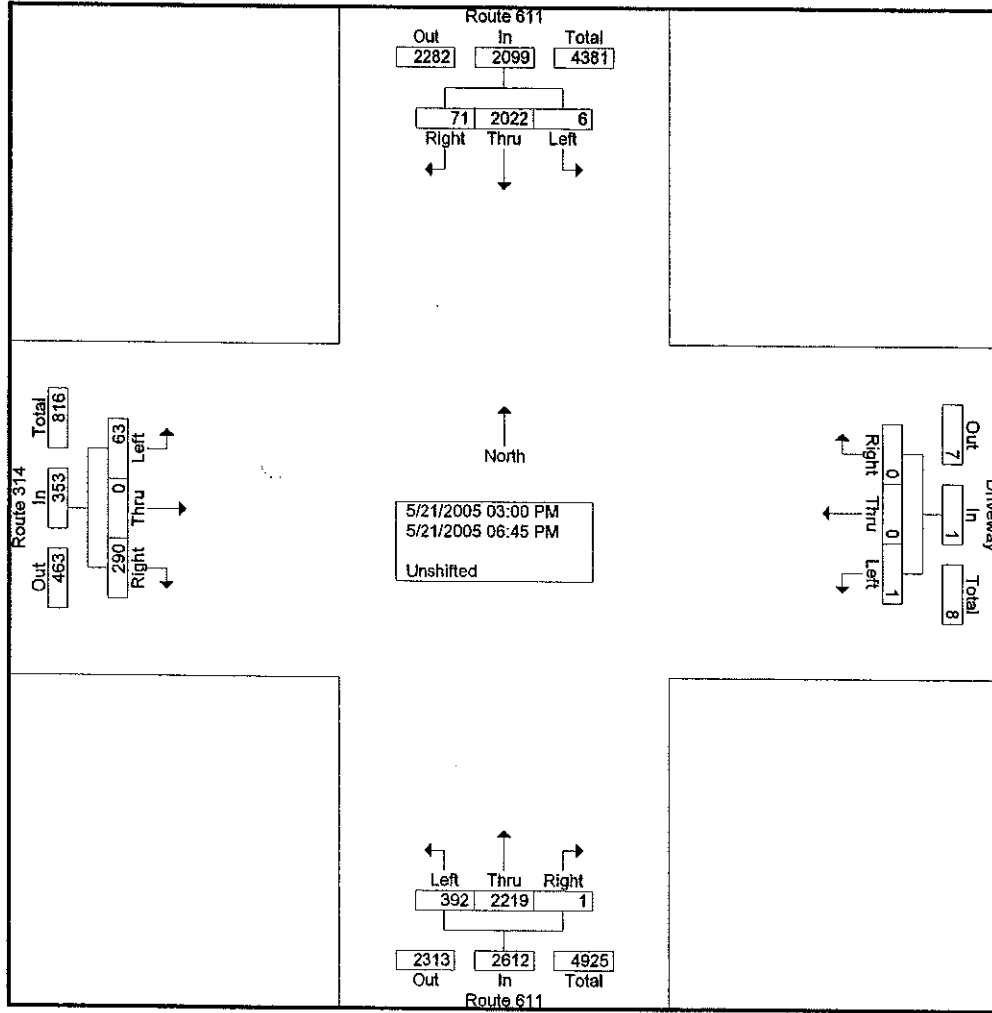

Start Time	Route 611 Southbound				Driveway Westbound				Route 611 Northbound				Route 314 Eastbound				Int. Total
	Left	Thru	Right	App. Total	Left	Thru	Right	App. Total	Left	Thru	Right	App. Total	Left	Thru	Right	App. Total	
Peak Hour Analysis From 03:00 PM to 06:45 PM - Peak 1 of 1																	
Peak Hour for Entire Intersection Begins at 03:00 PM																	
03:00 PM	0	145	4	149	0	0	0	0	27	153	0	180	3	0	24	27	356
03:15 PM	0	142	2	144	0	0	0	0	20	142	0	162	4	0	26	30	336
03:30 PM	0	134	4	138	0	0	0	0	38	144	0	182	4	0	18	22	342
03:45 PM	1	143	6	150	0	0	0	0	30	148	0	178	6	0	28	34	362
Total Volume	1	564	16	581	0	0	0	0	115	587	0	702	17	0	96	113	1396
% App. Total	0.2	97.1	2.8		0	0	0		16.4	83.6	0		15	0	85		
PHF	.250	.972	.667	.968	.000	.000	.000	.000	.757	.959	.000	.964	.708	.000	.857	.831	.964

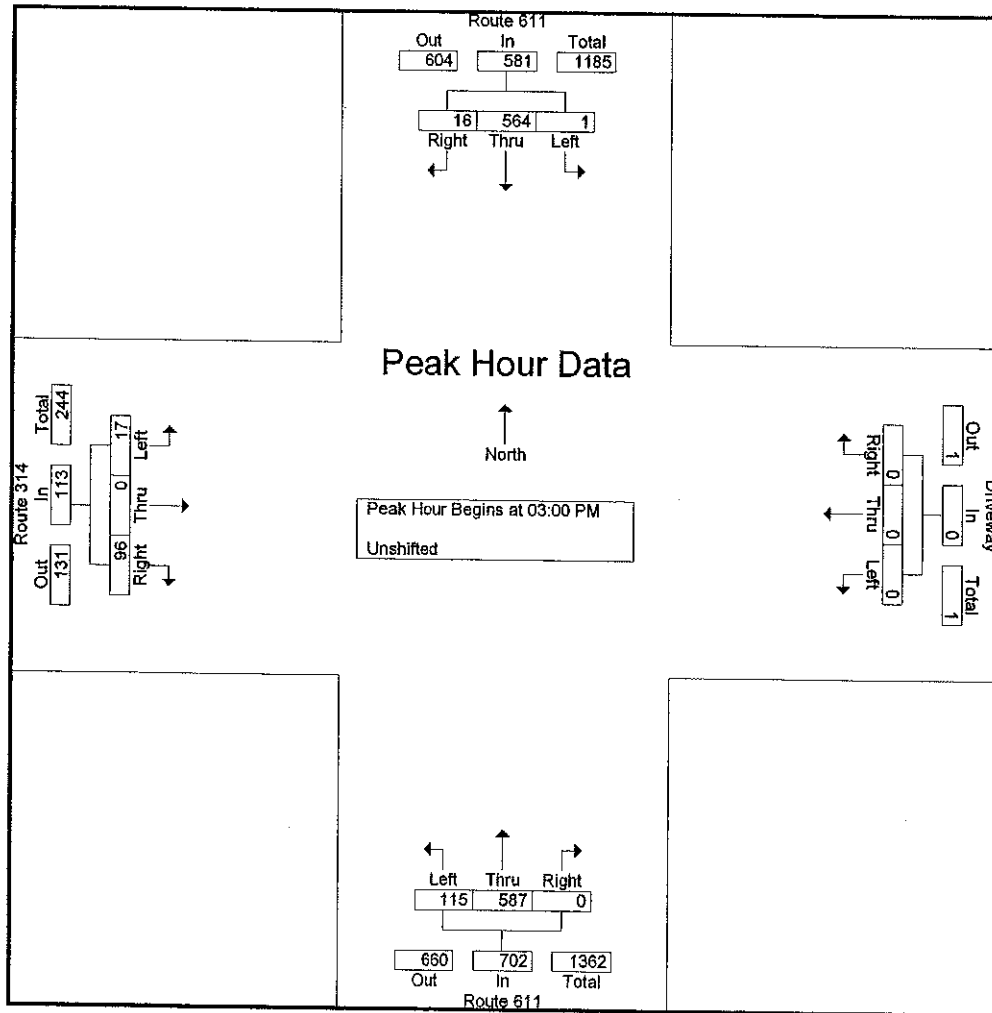

Counter: IMC 001  
 Counted By: C. Burnley  
 Weather: clear/rain  
 As: SAWR611

File Name : SAWR6112  
 Site Code : 00000000  
 Start Date : 5/21/2005  
 Page No : 1

Groups Printed- Unshifted

Start Time	Route 611 Southbound					Woodland Rd. Westbound					Route 611 Northbound					Big Daddy's Eastbound					Exclu. Total	Inclu. Total	Int. Total
	Left	Thru	Right	Truck	App. Total	Left	Thru	Right	Truck	App. Total	Left	Thru	Right	Truck	App. Total	Left	Thru	Right	Truck	App. Total			
Factor	1.0	1.0	1.0	1.0		1.0	1.0	1.0	1.0		1.0	1.0	1.0	1.0		1.0	1.0	1.0	1.0				
03:00 PM	0	134	2	1	136	14	0	1	0	15	1	155	10	1	166	3	0	4	0	7	2	324	326
03:15 PM	2	130	4	1	136	11	0	1	0	12	1	145	11	0	157	0	0	1	0	1	1	306	307
03:30 PM	2	128	3	2	133	11	0	3	0	14	4	148	12	0	164	2	0	4	0	6	2	317	319
03:45 PM	0	125	4	0	129	9	4	1	0	14	7	138	18	1	163	0	0	3	0	3	1	309	310
Total	4	517	13	4	534	45	4	6	0	55	13	586	51	2	650	5	0	12	0	17	6	1256	1262
04:00 PM	2	140	2	1	144	10	1	2	0	13	1	114	13	0	128	3	1	0	0	4	1	289	290
04:15 PM	3	122	2	2	127	11	1	1	0	13	1	161	13	0	175	2	2	1	0	5	2	320	322
04:30 PM	1	123	4	0	128	10	0	2	0	12	0	146	13	0	159	1	0	6	0	7	0	306	306
04:45 PM	2	129	3	1	134	14	3	3	0	20	5	144	11	0	160	2	0	3	1	5	2	319	321
Total	8	514	11	4	533	45	5	8	0	58	7	565	50	0	622	8	3	10	1	21	5	1234	1239
05:00 PM	0	107	4	0	111	17	0	1	0	18	6	158	11	1	175	2	0	0	0	2	1	306	307
05:15 PM	1	111	3	0	115	15	1	3	0	19	4	156	10	0	170	3	1	1	0	5	0	309	309
05:30 PM	0	114	3	0	117	13	2	4	1	19	2	155	9	2	166	4	2	2	0	8	3	310	313
05:45 PM	1	99	1	1	101	11	2	1	0	14	5	128	11	1	144	1	1	1	0	3	2	262	264
Total	2	431	11	1	444	56	5	9	1	70	17	597	41	4	655	10	4	4	0	18	6	1187	1193
06:00 PM	1	115	2	0	118	15	0	0	0	15	3	134	8	0	145	3	1	3	0	7	0	285	285
06:15 PM	2	96	2	0	100	11	1	5	0	17	8	135	8	1	151	5	1	2	0	8	1	276	277
06:30 PM	0	95	3	0	98	11	1	1	0	13	4	128	10	1	142	1	0	4	0	5	1	258	259
06:45 PM	4	104	2	2	110	5	2	1	0	8	10	124	17	1	151	3	2	5	0	10	3	279	282
Total	7	410	9	2	426	42	4	7	0	53	25	521	43	3	589	12	4	14	0	30	5	1098	1103
Grand Total	21	187	44	11	1937	188	18	30	1	236	62	226	185	9	2516	35	11	40	1	86	22	4775	4797
Apprch %	1.1	96.	2.3			79.	7.6	12.			2.5	90.	7.4			40.	12.	46.					
Total %	0.4	39.	0.9		40.6	3.9	0.4	0.6		4.9	1.3	47.	3.9		52.7	0.7	0.2	0.8		1.8	0.5	99.5	

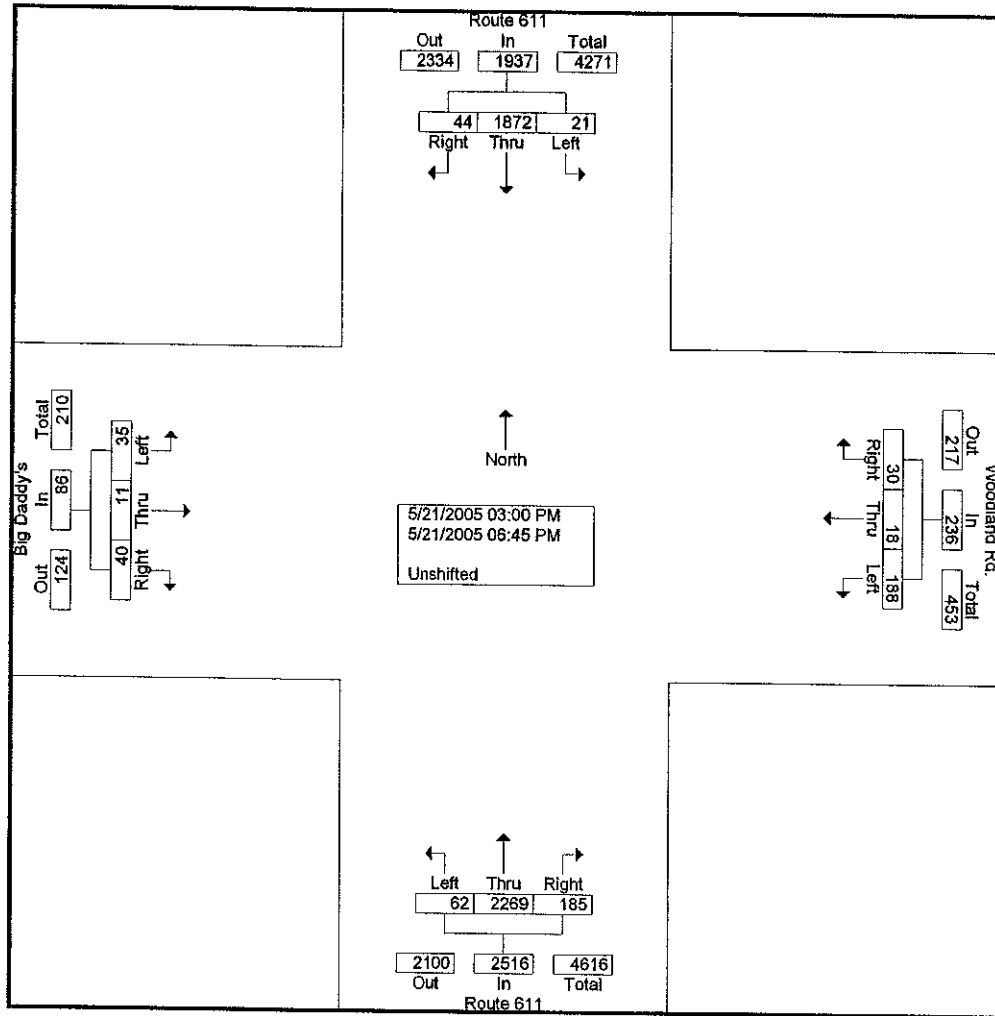

Start Time	Route 611 Southbound				Woodland Rd. Westbound				Route 611 Northbound				Big Daddy's Eastbound				Int. Total
	Left	Thru	Right	App. Total	Left	Thru	Right	App. Total	Left	Thru	Right	App. Total	Left	Thru	Right	App. Total	
Peak Hour Analysis From 03:00 PM to 04:15 PM - Peak 1 of 1																	
Peak Hour for Entire Intersection Begins at 03:00 PM																	
03:00 PM	0	134	2	136	14	0	1	15	1	155	10	166	3	0	4	7	324
03:15 PM	2	130	4	136	11	0	1	12	1	145	11	157	0	0	1	1	306
03:30 PM	2	128	3	133	11	0	3	14	4	148	12	164	2	0	4	6	317
03:45 PM	0	125	4	129	9	4	1	14	7	138	18	163	0	0	3	3	309
Total Volume	4	517	13	534	45	4	6	55	13	586	51	650	5	0	12	17	1256
% App. Total	0.7	96.8	2.4		81.8	7.3	10.9		2	90.2	7.8		29.4	0	70.6		
PHF	.500	.965	.813	.982	.804	.250	.500	.917	.464	.945	.708	.979	.417	.000	.750	.607	.969

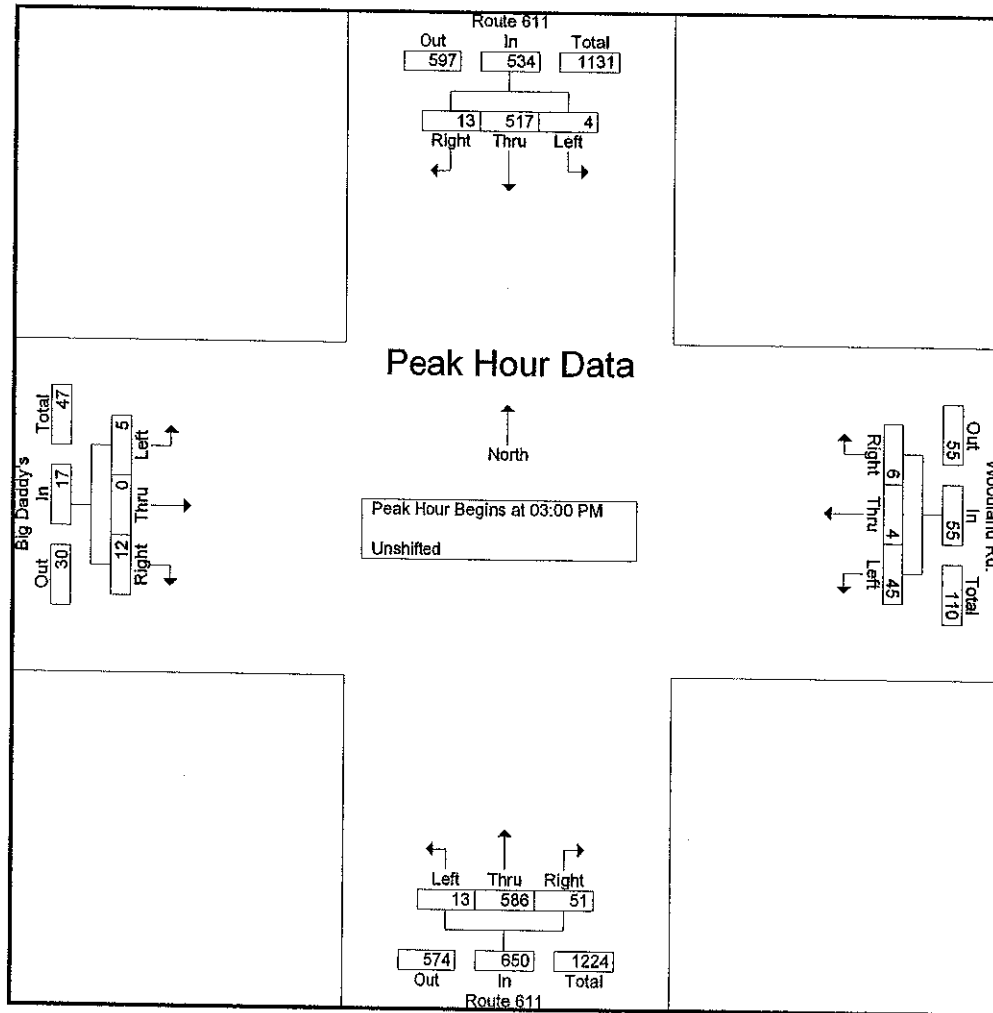



Job #: C. Burnley  
 Date: 5/21/05 (Saturday)  
 Technician: C. Burnley

Turning Movements To/From Strickland's Road								
Time	From SB Route 611	From NB Route 611	From Big Daddy's	From Woodland Road	To SB Route 611	To NB Route 611	To Big Daddy's	To Woodland Road
3:00 - 3:15 PM								
3:15 - 3:30 PM								
3:30 - 3:45 PM								
3:45 - 4:00 PM								
4:00 - 4:15 PM								
4:15 - 4:30 PM								
4:30 - 4:45 PM								
4:45 - 5:00 PM								
5:00 - 5:15 PM								
5:15 - 5:30 PM								
5:30 - 5:45 PM								
5:45 - 6:00 PM								
6:00 - 6:15 PM								
6:15 - 6:30 PM								
6:30 - 6:45 PM								
6:45 - 7:00 PM								

Peak Hour

Groups Printed- Unshifted

Start Time	Route 611 Southbound					Meadows Road Westbound					Route 611 Northbound					Trinity Hill Eastbound					Exclu. Total	Inclu. Total	Int. Total
	Left	Thru	Right	Trucks	App. Total	Left	Thru	Right	Trucks	App. Total	Left	Thru	Right	Trucks	App. Total	Left	Thru	Right	Trucks	App. Total			
Factor	1.0	1.0	1.0	1.0		1.0	1.0	1.0	1.0		1.0	1.0	1.0	1.0		1.0	1.0	1.0	1.0				
03:00 PM	4	125	0	0	129	0	0	0	0	0	0	166	2	1	168	0	0	0	0	0	1	297	298
03:15 PM	3	125	0	2	128	0	0	0	0	0	1	146	1	0	148	0	0	0	0	0	2	276	278
03:30 PM	0	144	0	4	144	1	1	0	0	2	0	157	1	0	158	0	0	0	0	0	4	304	308
03:45 PM	1	124	0	0	125	0	1	0	0	1	3	144	0	1	147	1	0	1	0	2	1	275	276
Total	8	518	0	6	526	1	2	0	0	3	4	613	4	2	621	1	0	1	0	2	8	1152	1160
04:00 PM	0	154	1	2	155	2	3	6	0	11	3	118	0	0	121	0	0	1	0	1	2	288	290
04:15 PM	0	129	0	1	129	0	1	2	0	3	0	153	0	0	153	0	0	1	0	1	1	286	287
04:30 PM	2	122	1	0	125	0	0	3	0	3	0	152	0	0	152	1	0	0	0	1	0	281	281
04:45 PM	1	129	1	1	131	0	0	0	0	0	0	163	1	0	164	1	0	0	0	1	1	296	297
Total	3	534	3	4	540	2	4	11	0	17	3	586	1	0	590	2	0	2	0	4	4	1151	1155
05:00 PM	0	125	0	0	125	0	0	1	0	1	0	157	1	0	158	0	1	1	0	2	0	286	286
05:15 PM	1	126	1	0	128	1	0	2	0	3	0	156	0	2	156	0	0	1	0	1	2	288	290
05:30 PM	2	114	0	0	116	1	0	2	0	3	1	158	0	2	159	0	0	1	0	1	2	279	281
05:45 PM	1	108	0	1	109	0	0	0	0	0	0	140	0	0	140	0	1	0	0	1	1	250	251
Total	4	473	1	1	478	2	0	5	0	7	1	611	1	4	613	0	2	3	0	5	5	1103	1108
06:00 PM	2	107	0	0	109	0	0	3	0	3	0	131	0	0	131	0	0	0	0	0	0	243	243
06:15 PM	2	108	0	0	110	0	0	1	0	1	0	137	0	1	137	0	0	1	0	1	1	249	250
06:30 PM	2	94	0	0	96	1	0	5	0	6	2	133	0	1	135	0	0	0	0	0	1	237	238
06:45 PM	2	105	0	2	107	0	0	2	0	2	0	123	2	1	125	0	2	1	0	3	3	237	240
Total	8	414	0	2	422	1	0	11	0	12	2	524	2	3	528	0	2	2	0	4	5	966	971
Grand Total	23	1939	4	13	1966	6	6	27	0	39	10	2334	8	9	2352	3	4	8	0	15	22	4372	4394
Apprch %	1.2	98.6	0.2			15.4	15.4	69.2			0.4	99.2	0.3			20.7	26.3	53.3					
Total %	0.5	44.4	0.1		45	0.1	0.1	0.6		0.9	0.2	53.4	0.2		53.8	0.1	0.1	0.2		0.3	0.5	99.5	

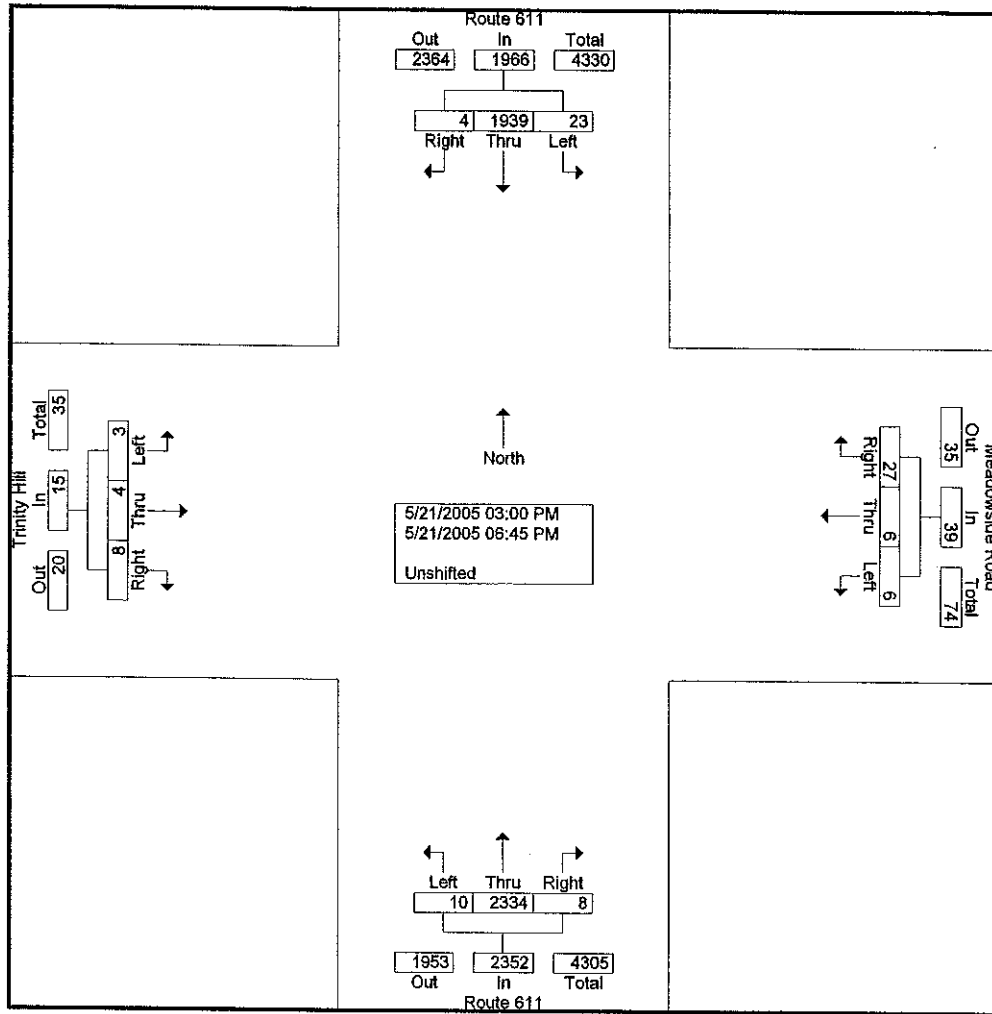

Start Time	Route 611 Southbound				Meadowside Road Westbound				Route 611 Northbound				Trinity Hill Eastbound				Int. Total
	Left	Thru	Right	App. Total	Left	Thru	Right	App. Total	Left	Thru	Right	App. Total	Left	Thru	Right	App. Total	
Peak Hour Analysis From 03:00 PM to 06:45 PM - Peak 1 of 1																	
Peak Hour for Entire Intersection Begins at 03:30 PM																	
03:30 PM	0	144	0	144	1	1	0	2	0	157	1	158	0	0	0	0	304
03:45 PM	1	124	0	125	0	1	0	1	3	144	0	147	1	0	1	2	275
04:00 PM	0	154	1	155	2	3	6	11	3	118	0	121	0	0	1	1	288
04:15 PM	0	129	0	129	0	1	2	3	0	153	0	153	0	0	1	1	286
Total Volume	1	551	1	553	3	6	8	17	6	572	1	579	1	0	3	4	1153
% App. Total	0.2	99.6	0.2		17.6	35.3	47.1		1	98.8	0.2		2.5	0	7.5		
PHF	.250	.894	.250	.892	.375	.500	.333	.386	.500	.911	.250	.916	.250	.000	.750	.500	.948

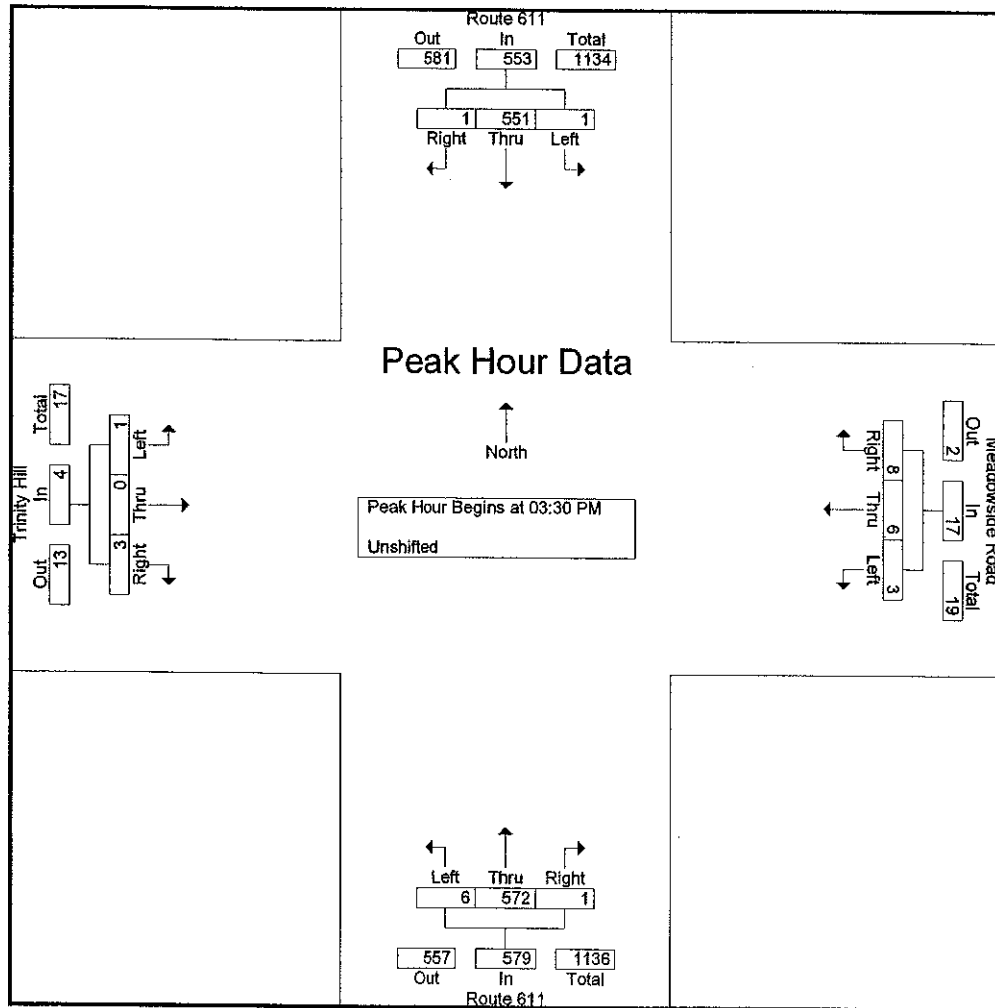

Route 611 & Grange Rd.

Counter: 1  
 Counted By: F. Montgomery  
 Weather: overcast  
 Sensors: SA611GR

Groups Printed- Unshifted

Start Time	Route 611 Southbound					Grange Rd. Westbound					Route 611 Northbound					Eastbound					Excl. Total	Incl. Total	Int. Total
	Left	Thru	Right	Truck	App. Total	Left	Thru	Right	Truck	App. Total	Left	Thru	Right	Truck	App. Total	Left	Thru	Right	Truck	App. Total			
03:00 PM	2	125	0	0	127	2	0	1	0	3	0	133	13	1	146	0	0	0	0	0	1	276	277
03:15 PM	3	125	0	0	128	0	0	6	0	6	0	185	6	0	191	0	0	0	0	0	0	325	325
03:30 PM	3	104	0	1	107	3	0	1	0	4	1	162	8	0	171	0	0	0	0	0	1	282	283
03:45 PM	1	138	0	2	139	3	0	4	0	7	0	148	2	0	150	0	0	0	0	0	2	296	298
Total	9	492	0	3	501	8	0	12	0	20	1	628	29	1	658	0	0	0	0	0	4	1179	1183
04:00 PM	2	121	0	1	123	4	0	4	0	8	0	189	2	0	191	0	0	0	0	0	1	322	323
04:15 PM	2	128	0	0	130	3	0	1	0	4	0	174	4	1	178	0	0	0	0	0	1	312	313
04:30 PM	2	121	0	1	123	3	0	2	0	5	0	180	2	0	182	0	0	0	0	0	1	310	311
04:45 PM	1	133	0	0	134	5	0	1	0	6	0	156	7	0	163	0	0	0	0	0	0	303	303
Total	7	503	0	2	510	15	0	8	0	23	0	699	15	1	714	0	0	0	0	0	3	1247	1250
05:00 PM	2	112	0	0	114	1	0	3	0	4	0	157	0	1	157	0	0	0	0	0	1	275	276
05:15 PM	4	143	0	1	147	0	0	3	0	3	0	151	2	0	153	0	0	0	0	0	1	303	304
05:30 PM	4	123	0	0	127	0	0	2	0	2	0	144	3	0	147	0	0	0	0	0	0	276	276
05:45 PM	2	108	0	0	110	2	0	6	0	8	0	133	3	0	136	0	0	0	0	0	0	254	254
Total	12	486	0	1	498	3	0	14	0	17	0	585	8	1	593	0	0	0	0	0	2	1108	1110
06:00 PM	5	127	0	1	132	4	0	1	0	5	0	160	1	1	161	0	0	0	0	0	2	298	300
06:15 PM	3	114	0	0	117	1	0	1	0	2	0	130	2	0	132	0	0	0	0	0	0	251	251
06:30 PM	2	113	0	0	115	0	0	0	0	0	0	116	3	0	119	0	0	0	0	0	0	234	234
06:45 PM	1	92	0	0	93	4	0	5	0	9	0	138	1	0	139	0	0	0	0	0	0	241	241
Total	11	446	0	1	457	9	0	7	0	16	0	544	7	1	551	0	0	0	0	0	2	1024	1026
Grand Total	39	1927	0	7	1966	35	0	41	0	76	1	2456	59	4	2516	0	0	0	0	0	11	4558	4569
Truck %	2	98	0			46.1	0	53.9			0	97.6	2.3			0	0	0					
Total %	0.9	42.3	0		43.1	0.8	0	0.9		1.7	0	53.9	1.3		55.2	0	0	0			0.2	99.8	

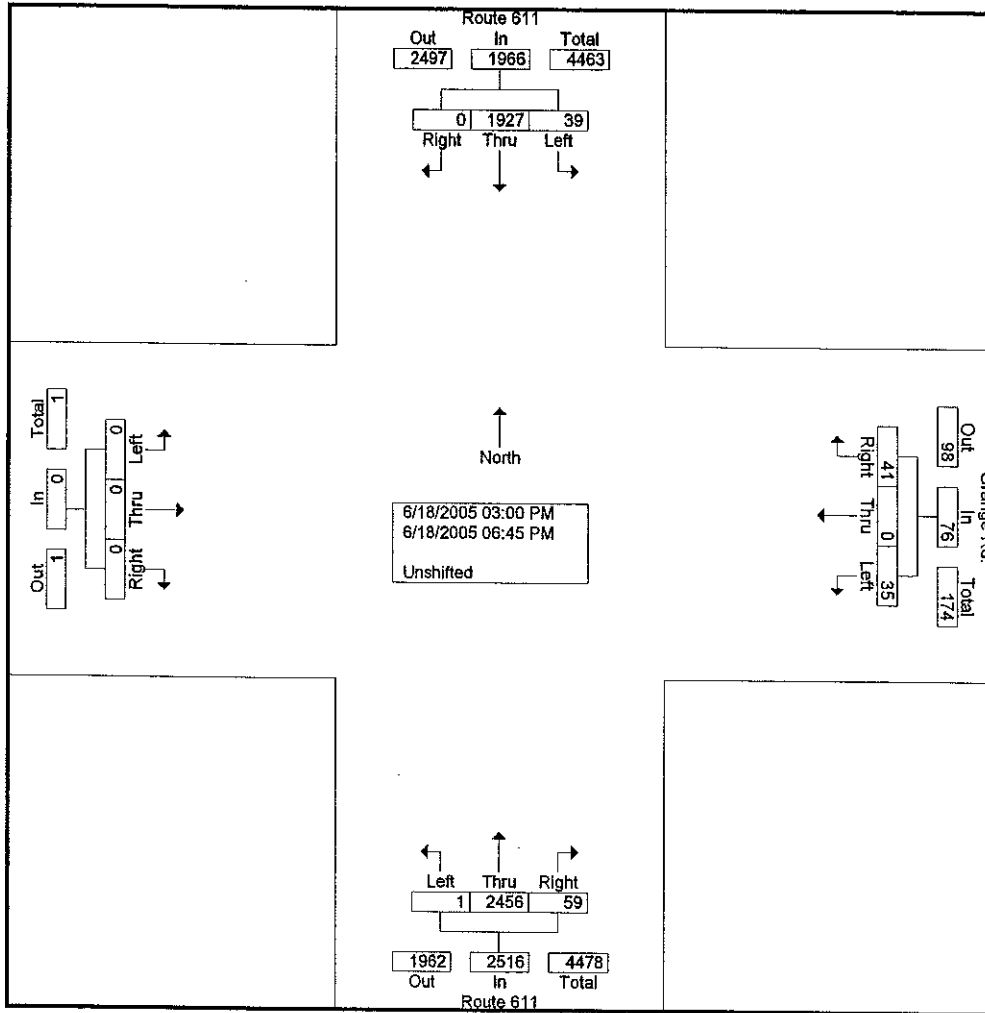

Start Time	Route 611 Southbound				Grange Rd. Westbound				Route 611 Northbound				Eastbound				Int. Total
	Left	Thru	Right	App. Total	Left	Thru	Right	App. Total	Left	Thru	Right	App. Total	Left	Thru	Right	App. Total	
Peak Hour Analysis From 03:00 PM to 06:45 PM - Peak 1 of 1																	
Peak Hour for Entire Intersection Begins at 04:00 PM																	
04:00 PM	2	121	0	123	4	0	4	8	0	189	2	191	0	0	0	0	322
04:15 PM	2	128	0	130	3	0	1	4	0	174	4	178	0	0	0	0	312
04:30 PM	2	121	0	123	3	0	2	5	0	180	2	182	0	0	0	0	310
04:45 PM	1	133	0	134	5	0	1	6	0	156	7	163	0	0	0	0	303
Total Volume	7	503	0	510	15	0	8	23	0	699	15	714	0	0	0	0	1247
% App. Total	1.4	98.6	0		65.2	0	34.8		0	97.9	2.1		0	0	0		
PIHF	.875	.945	.000	.951	.750	.000	.500	.719	.000	.925	.536	.935	.000	.000	.000	.000	.968

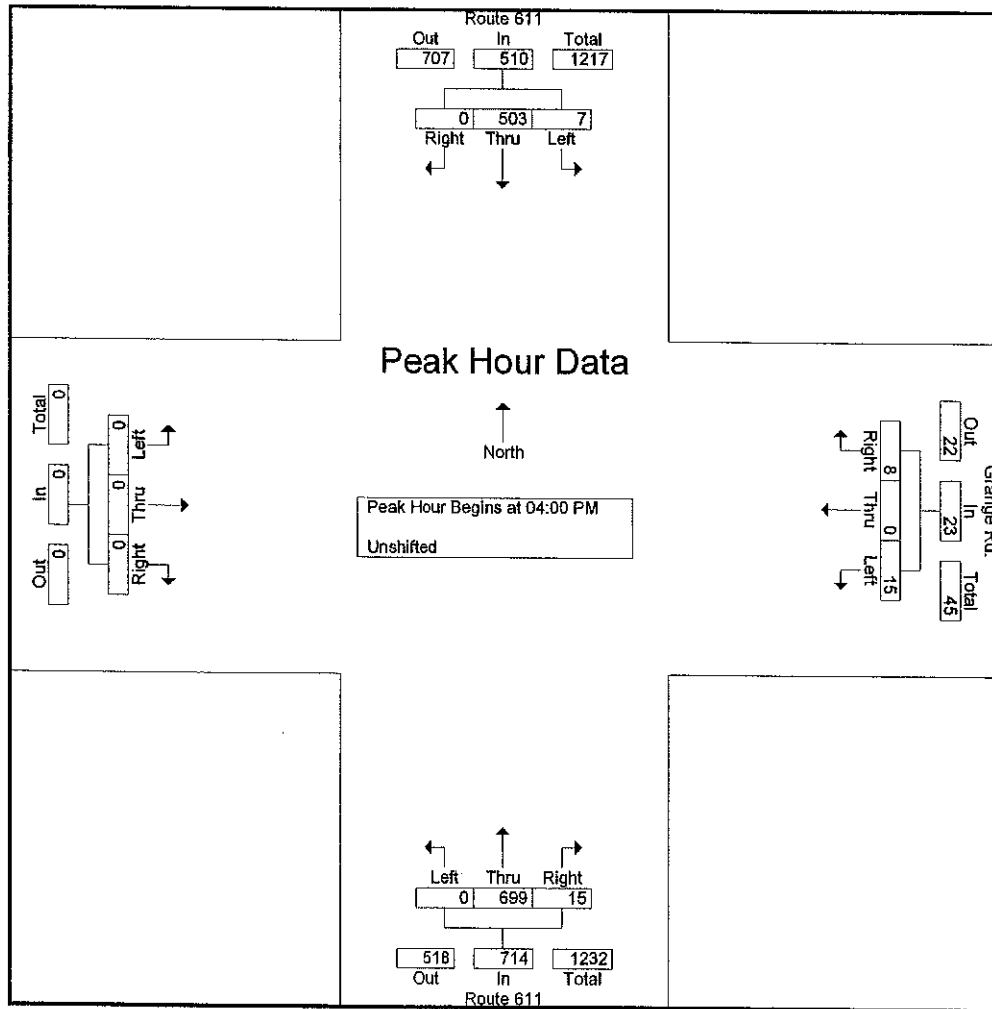

Counter: 88  
 Counted By: G. DiMartino  
 Weather: clear  
 1 As: SASAWR

File Name : SASAWR  
 Site Code : 00000000  
 Start Date : 5/21/2005  
 Page No : 1

Groups Printed- Unshifted

Start Time	Southbound					Woodland Rd. Westbound					School Access Road Northbound					Woodland Rd. Eastbound					Exclu. Total	Inclu. Total	Int. Total
	Left	Thru	Right	Truck	App. Total	Left	Thru	Right	Truck	App. Total	Left	Thru	Right	Truck	App. Total	Left	Thru	Right	Truck	App. Total			
Factor	1.0	1.0	1.0	1.0		1.0	1.0	1.0	1.0		1.0	1.0	1.0	1.0		1.0	1.0	1.0	1.0				
03:00 PM	0	0	0	0	0	0	17	0	0	17	0	0	1	0	1	0	10	0	0	10	0	28	28
03:15 PM	0	0	0	0	0	3	10	0	0	13	1	0	1	0	2	0	14	0	0	14	0	29	29
03:30 PM	0	0	0	0	0	0	14	0	0	14	1	0	0	0	1	0	13	2	0	15	0	30	30
03:45 PM	0	0	0	0	0	0	15	0	0	15	1	0	0	0	1	0	17	0	1	17	1	33	34
<b>Total</b>	0	0	0	0	0	3	56	0	0	59	3	0	2	0	5	0	54	2	1	56	1	120	121
04:00 PM	0	0	0	0	0	1	10	0	0	11	2	0	0	0	2	0	15	1	0	16	0	29	29
04:15 PM	0	0	0	0	0	1	13	0	0	14	1	0	0	0	1	0	15	3	0	18	0	33	33
04:30 PM	0	0	0	0	0	2	11	0	0	13	0	0	1	0	1	0	14	0	0	14	0	28	28
04:45 PM	0	0	0	0	0	0	18	0	0	18	1	0	0	0	1	0	13	0	0	13	0	32	32
<b>Total</b>	0	0	0	0	0	4	52	0	0	56	4	0	1	0	5	0	57	4	0	61	0	122	122
05:00 PM	0	0	0	0	0	0	18	0	0	18	0	0	1	0	1	0	10	0	0	10	0	29	29
05:15 PM	0	0	0	0	0	0	13	0	1	13	0	0	1	0	1	0	11	0	0	11	1	25	26
05:30 PM	0	0	0	0	0	1	13	0	0	14	0	0	1	0	1	0	10	2	0	12	0	27	27
05:45 PM	0	0	0	0	0	0	19	0	0	19	0	0	0	0	0	0	10	1	0	11	0	30	30
<b>Total</b>	0	0	0	0	0	1	63	0	1	64	0	0	3	0	3	0	41	3	0	44	1	111	112
06:00 PM	0	0	0	0	0	0	15	0	0	15	0	0	0	0	0	0	7	0	0	7	0	22	22
06:15 PM	0	0	0	0	0	0	14	0	0	14	0	0	0	0	0	0	11	0	0	11	0	25	25
06:30 PM	0	0	0	0	0	0	10	0	0	10	1	0	0	0	1	0	12	0	0	12	0	23	23
06:45 PM	0	0	0	0	0	1	7	0	0	8	0	0	0	0	0	0	16	0	0	16	0	24	24
<b>Total</b>	0	0	0	0	0	1	46	0	0	47	1	0	0	0	1	0	46	0	0	46	0	94	94
<b>Grand Total</b>	0	0	0	0	0	9	217	0	1	226	8	0	6	0	14	0	198	9	1	207	2	447	449
<b>Apprch %</b>	0	0	0			4	96	0			57.	0	42.			0	95.	4.3					
<b>Total %</b>	0	0	0			2	48.	0		50.6	1.8	0	1.3		3.1	0	44.	2		46.3	0.4	99.6	



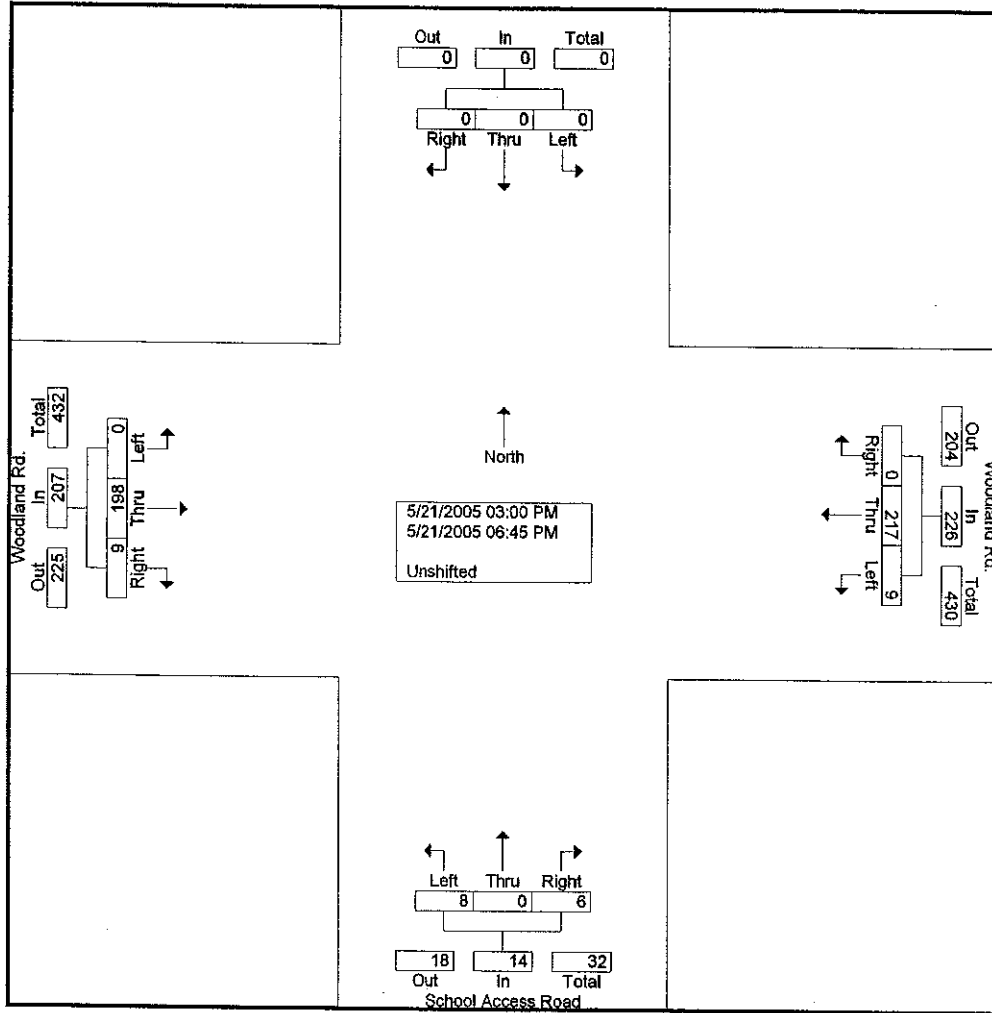

Start Time	Southbound				Woodland Rd. Westbound				School Access Road Northbound				Woodland Rd. Eastbound				Int. Total
	Left	Thru	Right	App. Total	Left	Thru	Right	App. Total	Left	Thru	Right	App. Total	Left	Thru	Right	App. Total	
Peak Hour Analysis From 03:00 PM to 06:45 PM - Peak 1 of 1																	
Peak Hour for Entire Intersection Begins at 03:30 PM																	
03:30 PM	0	0	0	0	0	14	0	14	1	0	0	1	0	13	2	15	30
03:45 PM	0	0	0	0	0	15	0	15	1	0	0	1	0	17	0	17	33
04:00 PM	0	0	0	0	1	10	0	11	2	0	0	2	0	15	1	16	29
04:15 PM	0	0	0	0	1	13	0	14	1	0	0	1	0	15	3	18	33
Total Volume	0	0	0	0	2	52	0	54	5	0	0	5	0	60	6	66	125
% App. Total	0	0	0	0	3.7	96.3	0	100	0	0	0	0	0	90.9	9.1		
PHF	.000	.000	.000	.000	.500	.867	.000	.900	.625	.000	.000	.625	.000	.882	.500	.917	.947

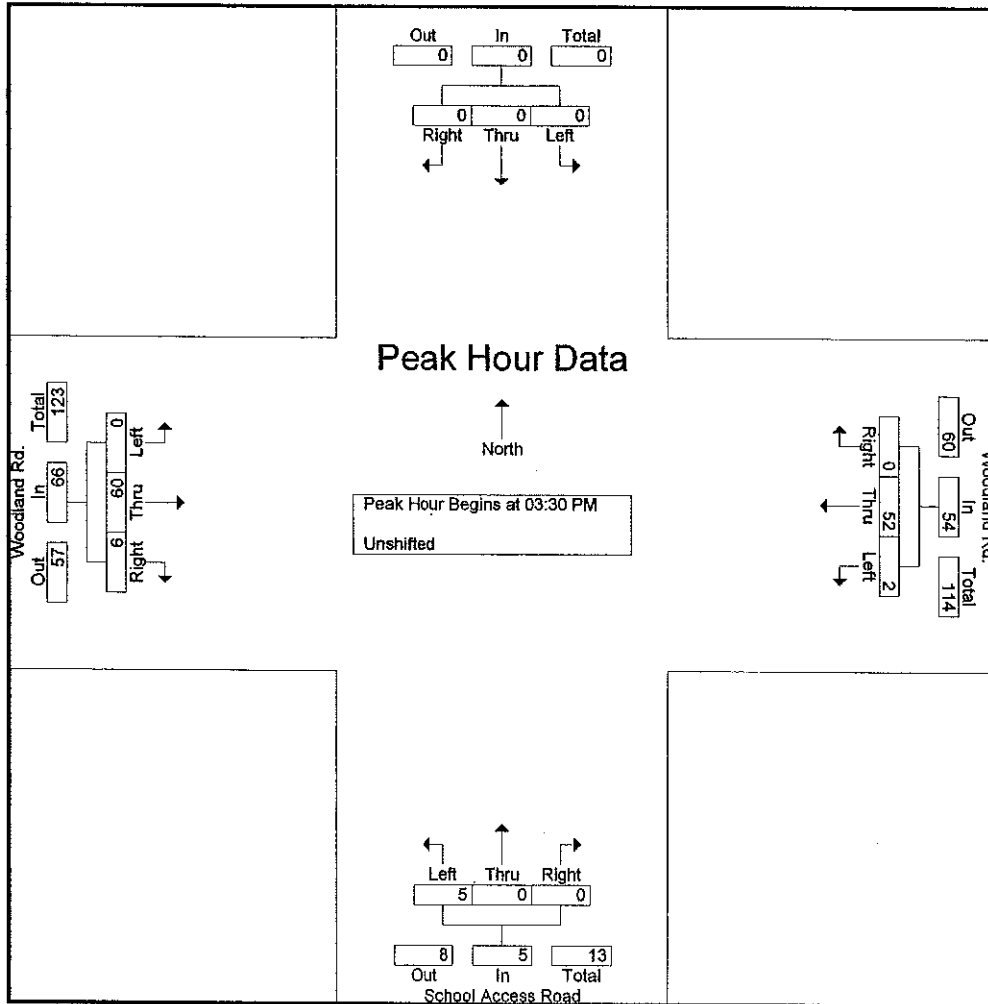

Counter: 9  
 Counted By: R. Kearney  
 Weather: clear  
 1 As: SAWRBR

File Name : SAWRBR  
 Site Code : 00000000  
 Start Date : 5/21/2005  
 Page No : 1

Groups Printed- Unshifted

Start Time	Southbound					Woodland Rd. Westbound					Bowman Rd. Northbound					Woodland Rd. Eastbound					Exclu. Total	Inclu. Total	Int. Total
	Left	Thru	Right	Truck	App. Total	Left	Thru	Right	Truck	App. Total	Left	Thru	Right	Truck	App. Total	Left	Thru	Right	Truck	App. Total			
Factor	1.0	1.0	1.0	1.0		1.0	1.0	1.0	1.0		1.0	1.0	1.0	1.0		1.0	1.0	1.0	1.0				
03:00 PM	1	0	0	0	1	0	17	0	0	17	0	0	0	0	0	0	10	0	0	10	0	28	28
03:15 PM	0	0	0	0	0	1	11	0	0	12	1	0	1	0	2	0	16	1	1	17	1	31	32
03:30 PM	0	0	0	0	0	1	16	0	0	17	0	0	1	0	1	0	15	0	0	15	0	33	33
03:45 PM	0	0	0	0	0	0	10	0	0	10	0	0	0	0	0	0	14	0	0	14	0	24	24
Total	1	0	0	0	1	2	54	0	0	56	1	0	2	0	3	0	55	1	1	56	1	116	117
04:00 PM	0	0	0	0	0	1	9	0	0	10	0	0	1	0	1	0	16	2	0	18	0	29	29
04:15 PM	0	0	0	0	0	0	15	0	0	15	1	0	2	0	3	0	11	0	0	11	0	29	29
04:30 PM	0	0	0	0	0	2	15	0	0	17	0	0	0	0	0	0	13	0	0	13	0	30	30
04:45 PM	0	0	0	0	0	0	16	0	0	16	1	0	1	0	2	0	16	0	1	16	1	34	35
Total	0	0	0	0	0	3	55	0	0	58	2	0	4	0	6	0	56	2	1	58	1	122	123
05:00 PM	0	0	0	0	0	1	16	0	0	17	1	0	0	0	1	0	10	0	0	10	0	28	28
05:15 PM	0	0	0	0	0	1	10	0	1	11	1	0	0	0	1	0	12	0	0	12	1	24	25
05:30 PM	0	0	0	0	0	0	18	0	0	18	0	0	1	0	1	0	11	0	0	11	0	30	30
05:45 PM	0	0	0	0	0	1	15	0	0	16	0	0	0	0	0	0	9	0	0	9	0	25	25
Total	0	0	0	0	0	3	59	0	1	62	2	0	1	0	3	0	42	0	0	42	1	107	108
06:00 PM	0	0	0	0	0	1	17	0	1	18	0	0	1	0	1	0	8	0	0	8	1	27	28
06:15 PM	0	0	0	0	0	1	10	0	0	11	0	0	0	0	0	0	9	0	0	9	0	20	20
06:30 PM	0	0	0	0	0	1	10	0	0	11	0	0	1	0	1	0	14	0	0	14	0	26	26
06:45 PM	0	0	0	0	0	1	11	0	0	12	2	0	1	0	3	0	17	0	0	17	0	32	32
Total	0	0	0	0	0	4	48	0	1	52	2	0	3	0	5	0	48	0	0	48	1	105	106
Grand Total	1	0	0	0	1	12	216	0	2	228	7	0	10	0	17	0	201	3	2	204	4	450	454
Apprch %	100	0	0			5.3	94.7	0			41.2	0	58.8			0	98.5	1.5					
Total %	0.2	0	0		0.2	2.7	48	0		50.7	1.6	0	2.2		3.8	0	44.7	0.7		45.3	0.9	99.1	

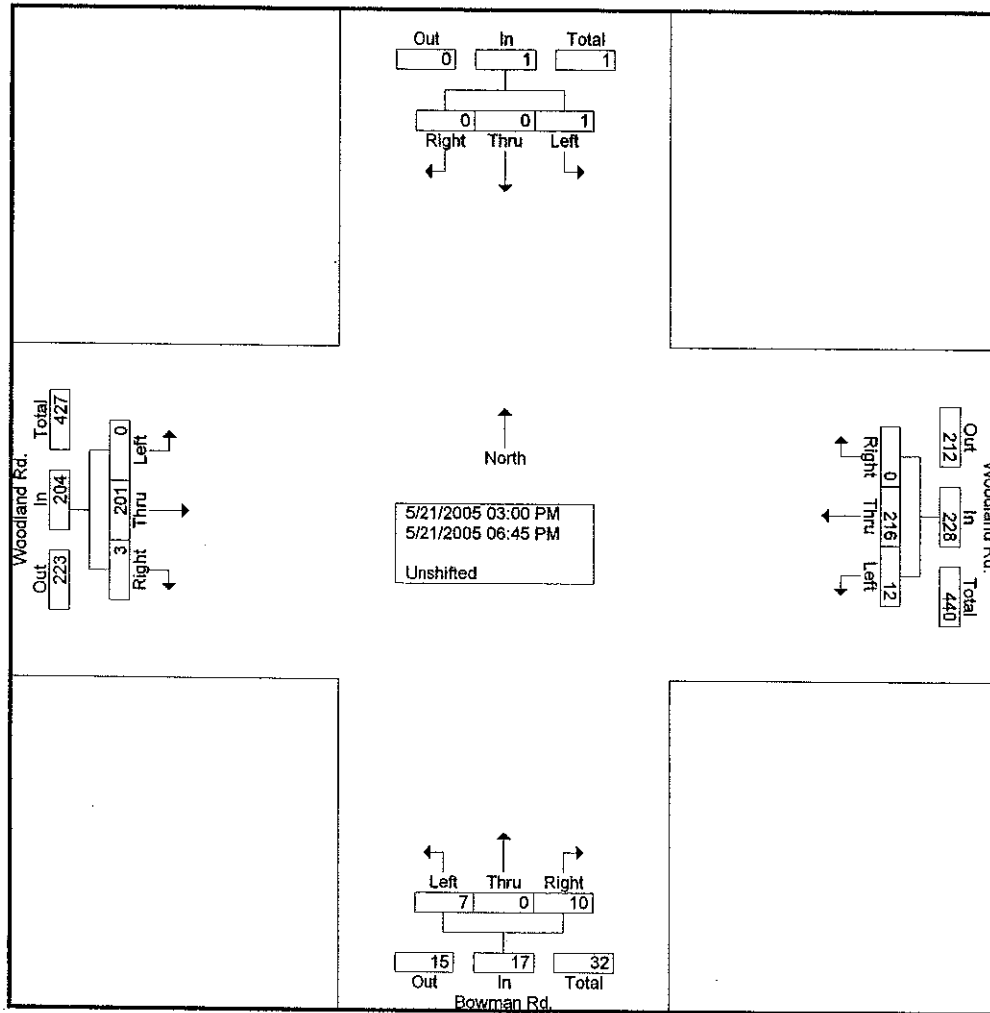

Start Time	Southbound				Woodland Rd. Westbound				Bowman Rd. Northbound				Woodland Rd. Eastbound				Int. Total
	Left	Thru	Right	App. Total	Left	Thru	Right	App. Total	Left	Thru	Right	App. Total	Left	Thru	Right	App. Total	
Peak Hour Analysis From 03:00 PM to 06:45 PM - Peak 1 of 1																	
Peak Hour for Entire Intersection Begins at 04:00 PM																	
04:00 PM	0	0	0	0	1	9	0	10	0	0	1	1	0	16	2	18	29
04:15 PM	0	0	0	0	0	15	0	15	1	0	2	3	0	11	0	11	29
04:30 PM	0	0	0	0	2	15	0	17	0	0	0	0	0	13	0	13	30
04:45 PM	0	0	0	0	0	16	0	16	1	0	1	2	0	16	0	16	34
Total Volume	0	0	0	0	3	55	0	58	2	0	4	6	0	56	2	58	122
% App. Total	0	0	0	0	5.2	94.8	0		33.3	0	66.7		0	96.6	3.4		
PHF	.000	.000	.000	.000	.375	.859	.000	.853	.500	.000	.500	.500	.000	.875	.250	.806	.897

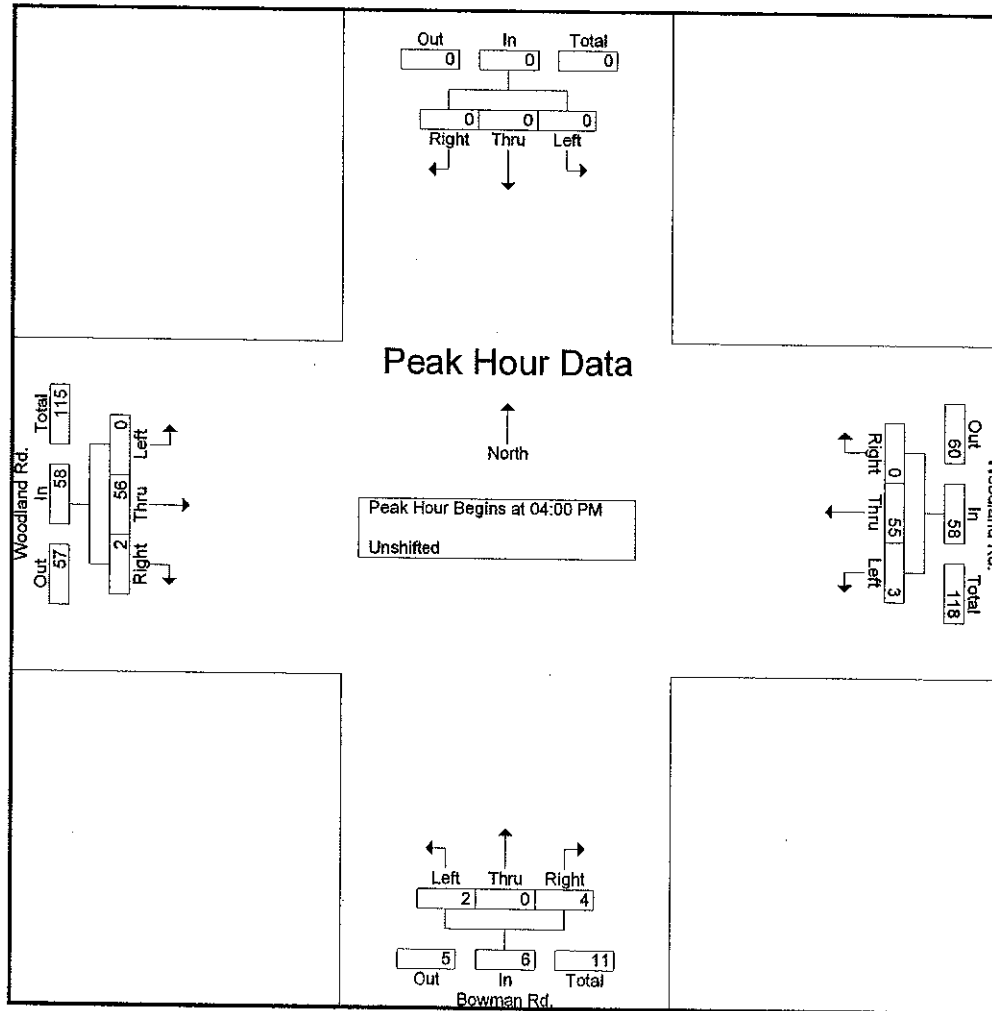

Counter: 1  
 Counted By: M. McGarrigle  
 Weather: clear  
 As: SAWRMR

File Name : SAWRMR  
 Site Code : 00052105  
 Start Date : 5/21/2005  
 Page No : 1

Groups Printed- Unshifted

Start Time	Meadowside Rd. Southbound					Woodland Rd. Westbound					Northbound					Woodland Rd. Eastbound					Exclu. Total	Inclu. Total	Int. Total
	Left	Thru	Right	Truck	App. Total	Left	Thru	Right	Truck	App. Total	Left	Thru	Right	Truck	App. Total	Left	Thru	Right	Truck	App. Total			
Factor	1.0	1.0	1.0	1.0		1.0	1.0	1.0	1.0		1.0	1.0	1.0	1.0		1.0	1.0	1.0	1.0				
03:00 PM	1	0	2	0	3	0	15	1	0	16	0	0	0	0	0	0	11	0	0	11	0	30	30
03:15 PM	1	0	1	0	2	0	12	0	0	12	0	0	0	0	0	0	15	0	0	15	0	29	29
03:30 PM	0	0	0	0	0	0	13	2	0	15	0	0	0	0	0	1	13	0	0	14	0	29	29
03:45 PM	1	0	1	0	2	0	15	2	0	17	0	0	0	0	0	1	14	0	0	15	0	34	34
Total	3	0	4	0	7	0	55	5	0	60	0	0	0	0	0	2	53	0	0	55	0	122	122
04:00 PM	1	0	0	0	1	0	11	3	0	14	0	0	0	0	0	0	13	0	0	13	0	28	28
04:15 PM	1	0	0	0	1	0	15	2	0	17	0	0	0	0	0	1	13	0	0	14	0	32	32
04:30 PM	0	0	1	0	1	0	14	1	0	15	0	0	0	0	0	0	15	0	0	15	0	31	31
04:45 PM	0	0	0	0	0	0	16	0	0	16	0	0	0	0	0	0	12	0	0	12	0	28	28
Total	2	0	1	0	3	0	56	6	0	62	0	0	0	0	0	1	53	0	0	54	0	119	119
05:00 PM	1	0	0	0	1	0	15	1	0	16	0	0	0	0	0	0	13	0	0	13	0	30	30
05:15 PM	1	0	0	0	1	0	13	1	1	14	0	0	0	0	0	0	13	0	0	13	1	28	29
05:30 PM	2	0	0	0	2	0	14	1	0	15	0	0	0	0	0	0	9	0	0	9	0	26	26
05:45 PM	2	0	0	0	2	0	16	0	0	16	0	0	0	0	0	0	10	0	0	10	0	28	28
Total	6	0	0	0	6	0	58	3	1	61	0	0	0	0	0	0	45	0	0	45	1	112	113
06:00 PM	2	0	1	0	3	0	14	1	0	15	0	0	0	0	0	0	8	0	0	8	0	26	26
06:15 PM	0	0	0	0	0	0	14	1	0	15	0	0	0	0	0	1	8	0	0	9	0	24	24
06:30 PM	1	0	1	0	2	0	10	3	0	13	0	0	0	0	0	0	15	0	0	15	0	30	30
06:45 PM	3	0	1	0	4	0	8	0	0	8	0	0	0	0	0	0	19	0	0	19	0	31	31
Total	6	0	3	0	9	0	46	5	0	51	0	0	0	0	0	1	50	0	0	51	0	111	111
Grand Total	17	0	8	0	25	0	215	19	1	234	0	0	0	0	0	4	201	0	0	205	1	464	465
Apprch %	68	0	32			0	91.9	8.1			0	0	0			2	98	0					
Total %	3.7	0	1.7		5.4	0	46.3	4.1		50.4	0	0	0		0	0.9	43.3	0		44.2	0.2	99.8	

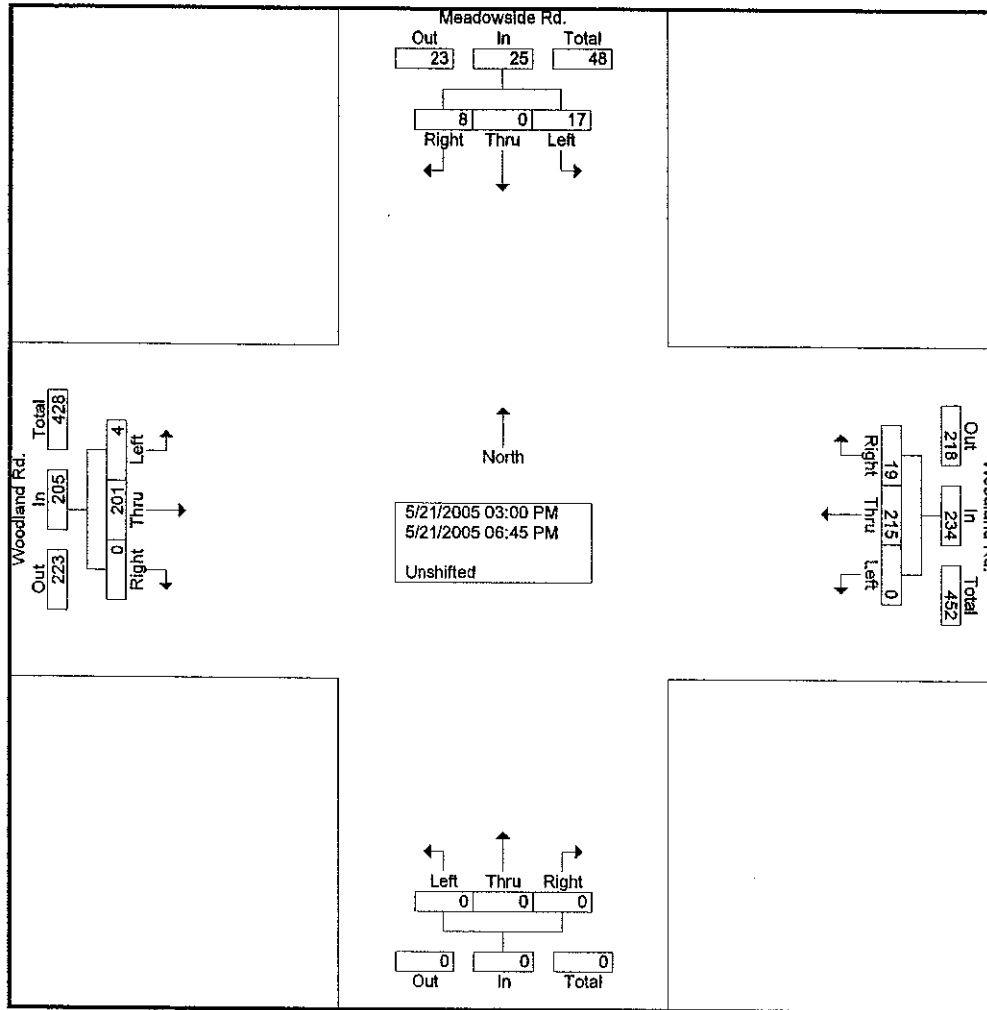

Start Time	Meadowside Rd. Southbound				Woodland Rd. Westbound				Northbound				Woodland Rd. Eastbound				Int. Total
	Left	Thru	Right	App. Total	Left	Thru	Right	App. Total	Left	Thru	Right	App. Total	Left	Thru	Right	App. Total	
Peak Hour Analysis From 03:00 PM to 06:45 PM - Peak 1 of 1																	
Peak Hour for Entire Intersection Begins at 03:45 PM																	
03:45 PM	1	0	1	2	0	15	2	17	0	0	0	0	1	14	0	15	34
04:00 PM	1	0	0	1	0	11	3	14	0	0	0	0	0	13	0	13	28
04:15 PM	1	0	0	1	0	15	2	17	0	0	0	0	1	13	0	14	32
04:30 PM	0	0	1	1	0	14	1	15	0	0	0	0	0	15	0	15	31
Total Volume	3	0	2	5	0	55	8	63	0	0	0	0	2	55	0	57	125
% App. Total	60	0	40		0	87.3	12.7		0	0	0		3.5	96.5	0		
PHF	.750	.000	.500	.625	.000	.917	.667	.926	.000	.000	.000	.000	.500	.917	.000	.950	.919

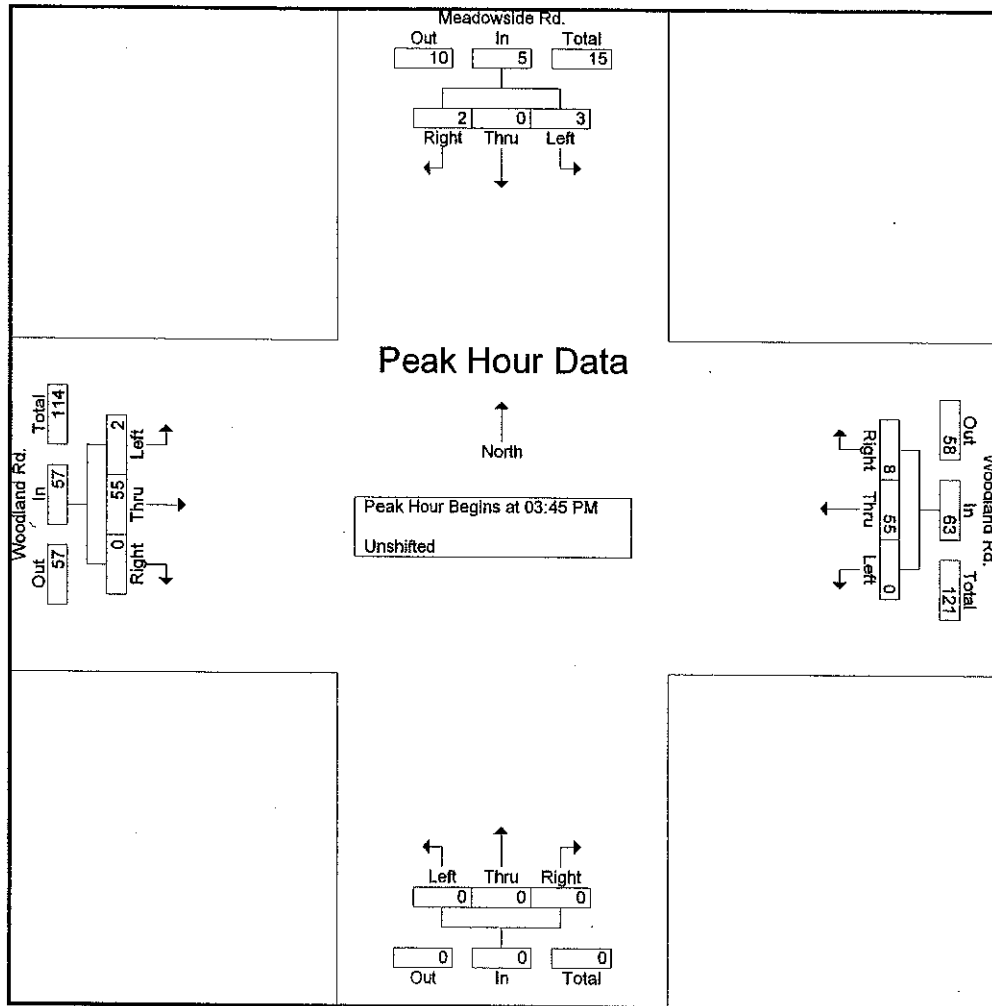



Counter: 17  
 Counted By: M. Bressler  
 Weather: clear  
 As: SACRWR

File Name : SACRWR  
 Site Code : 0000012  
 Start Date : 5/21/2005  
 Page No : 1

Groups Printed- Unshifted

Start Time	Woodland Rd. Southbound					Westbound					Woodland Rd. Northbound					Carlton Rd. Eastbound					Exclu. Total	Inclu. Total	Int. Total
	Left	Thru	Right	Truck	App. Total	Left	Thru	Right	Truck	App. Total	Left	Thru	Right	Truck	App. Total	Left	Thru	Right	Truck	App. Total			
Factor	1.0	1.0	1.0	1.0		1.0	1.0	1.0	1.0		1.0	1.0	1.0	1.0		1.0	1.0	1.0	1.0				
03:00 PM	0	26	17	0	43	0	0	0	0	0	0	18	0	0	18	13	0	1	0	14	0	75	75
03:15 PM	0	12	11	0	23	0	0	0	0	0	1	25	0	1	26	10	0	0	0	10	1	59	60
03:30 PM	0	24	13	0	37	0	0	0	0	0	3	24	0	0	27	16	0	0	0	16	0	80	80
03:45 PM	0	19	14	0	33	0	0	0	0	0	0	29	0	1	29	12	0	0	0	12	1	74	75
Total	0	81	55	0	136	0	0	0	0	0	4	96	0	2	100	51	0	1	0	52	2	288	290
04:00 PM	0	20	11	1	31	0	0	0	0	0	2	31	0	0	33	14	0	0	0	14	1	78	79
04:15 PM	0	28	16	1	44	0	0	0	0	0	1	21	0	0	22	14	0	1	0	15	1	81	82
04:30 PM	0	20	12	0	32	0	0	0	0	0	1	27	0	0	28	15	0	0	0	15	0	75	75
04:45 PM	0	22	10	0	32	0	0	0	0	0	0	22	0	0	22	11	0	0	0	11	0	65	65
Total	0	90	49	2	139	0	0	0	0	0	4	101	0	0	105	54	0	1	0	55	2	299	301
05:00 PM	0	28	16	0	44	0	0	0	0	0	1	35	0	0	36	17	0	0	0	17	0	97	97
05:15 PM	0	18	10	1	28	0	0	0	0	0	2	24	0	0	26	11	0	1	0	12	1	66	67
05:30 PM	0	20	13	0	33	0	0	0	0	0	0	27	0	0	27	10	0	1	0	11	0	71	71
05:45 PM	0	12	17	0	29	0	0	0	0	0	0	19	0	0	19	16	0	0	0	16	0	64	64
Total	0	78	56	1	134	0	0	0	0	0	3	105	0	0	108	54	0	2	0	56	1	298	299
06:00 PM	0	24	10	0	34	0	0	0	0	0	0	17	0	0	17	11	0	0	0	11	0	62	62
06:15 PM	0	20	16	0	36	0	0	0	0	0	0	19	0	0	19	15	0	2	0	17	0	72	72
06:30 PM	0	24	15	1	39	0	0	0	0	0	0	23	0	2	23	10	0	0	0	10	3	72	75
06:45 PM	0	5	6	0	11	0	0	0	0	0	1	29	0	0	30	28	0	0	0	28	0	69	69
Total	0	73	47	1	120	0	0	0	0	0	1	88	0	2	89	64	0	2	0	66	3	275	278
Grand Total	0	322	207	4	529	0	0	0	0	0	12	390	0	4	402	223	0	6	0	229	8	1160	1168
Apprch %	0	60.9	39.1			0	0	0			3	97	0			97.4	0	2.6					
Total %	0	27.8	17.8		45.6	0	0	0			1	33.6	0		34.7	19.2	0	0.5		19.7	0.7	99.3	

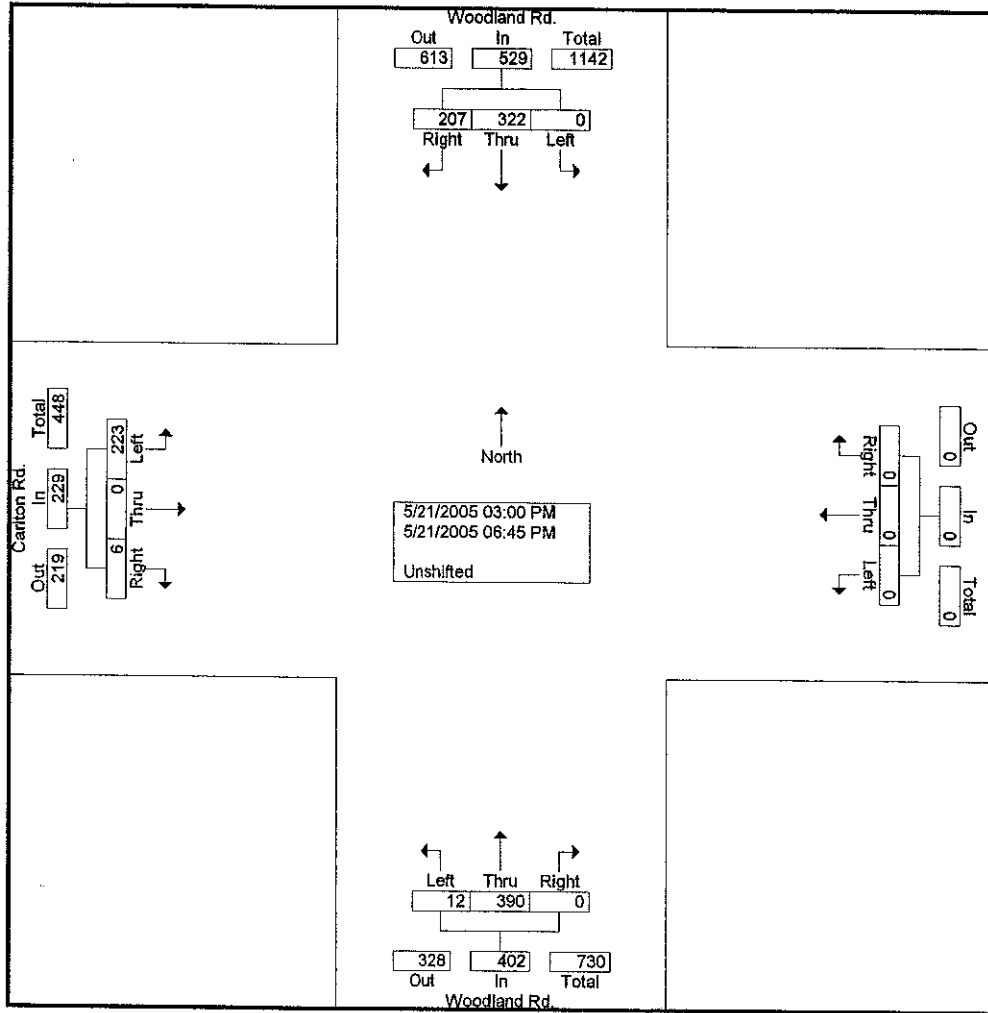

Start Time	Woodland Rd. Southbound				Westbound				Woodland Rd. Northbound				Carlton Rd. Eastbound				Int. Total
	Left	Thru	Right	App. Total	Left	Thru	Right	App. Total	Left	Thru	Right	App. Total	Left	Thru	Right	App. Total	
Peak Hour Analysis From 03:00 PM to 06:45 PM - Peak 1 of 1																	
Peak Hour for Entire Intersection Begins at 04:15 PM																	
04:15 PM	0	28	16	44	0	0	0	0	1	21	0	22	14	0	1	15	81
04:30 PM	0	20	12	32	0	0	0	0	1	27	0	28	15	0	0	15	75
04:45 PM	0	22	10	32	0	0	0	0	0	22	0	22	11	0	0	11	65
05:00 PM	0	28	16	44	0	0	0	0	1	35	0	36	17	0	0	17	97
Total Volume	0	98	54	152	0	0	0	0	3	105	0	108	57	0	1	58	318
% App. Total	0	64.5	35.5		0	0	0		2.8	97.2	0		98.3	0	1.7		
PHF	.000	.875	.844	.864	.000	.000	.000	.000	.750	.750	.000	.750	.838	.000	.250	.853	.820

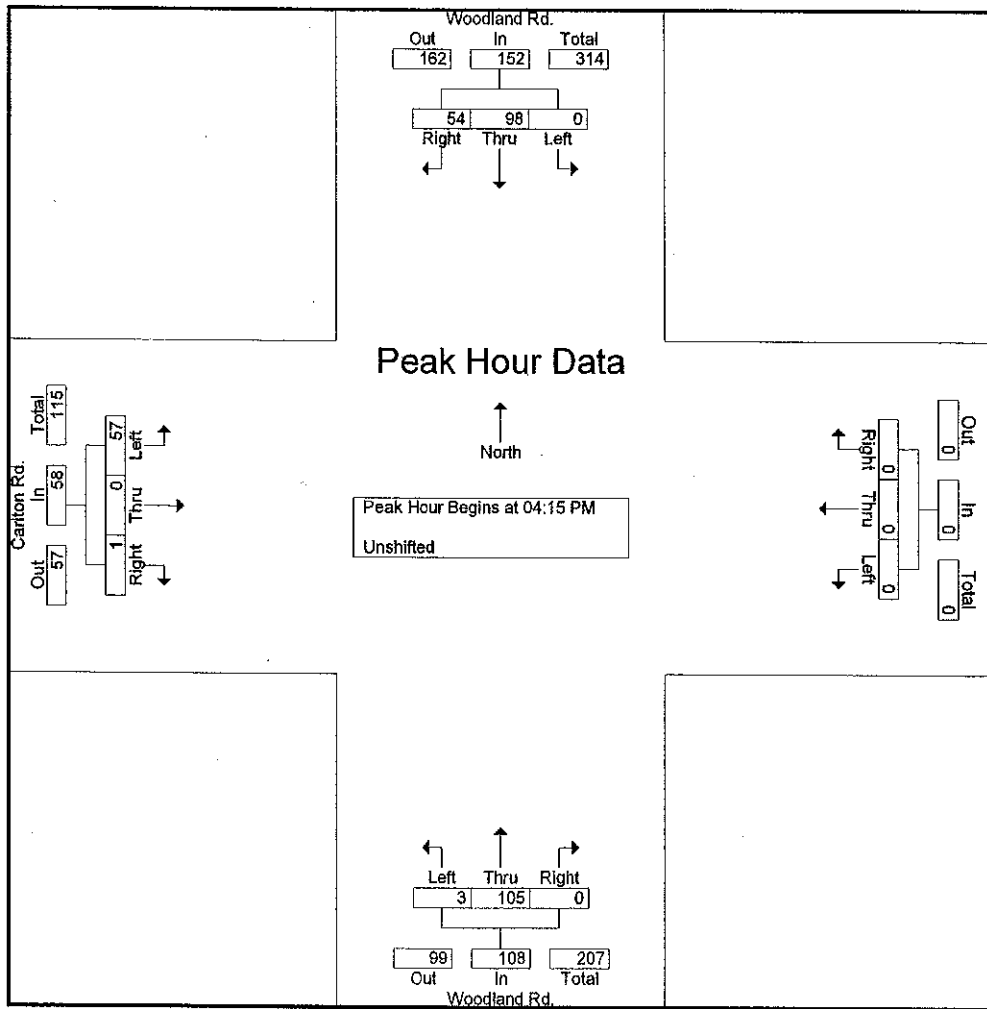

Traffic Planning & Design, Inc.  
 2500 E High St. Suite 650  
 Pottstown, PA 19464  
**Route 940 & Carlton Rd./Resort Driveway**

Counter: 2  
 Counted By: J. Janos  
 Weather: clear  
 Id As: SA940CR

File Name : SA940CR  
 Site Code : 00000000  
 Start Date : 5/21/2005  
 Page No : 1

**Groups Printed- Unshifted**

Start Time	Resort Driveway Southbound					Route 940 Westbound					Carlton Rd. Northbound					Route 940 Eastbound					Excl. Total	Incl. Total	Int. Total
	Left	Thru	Right	Truck	App. Total	Left	Thru	Right	Truck	App. Total	Left	Thru	Right	Truck	App. Total	Left	Thru	Right	Truck	App. Total			
Factor	1.0	1.0	1.0	1.0		1.0	1.0	1.0	1.0		1.0	1.0	1.0	1.0		1.0	1.0	1.0	1.0				
03:45 PM	0	0	1	0	1	29	78	0	0	107	7	0	34	0	41	4	74	2	0	80	0	229	229
Total	0	0	1	0	1	29	78	0	0	107	7	0	34	0	41	4	74	2	0	80	0	229	229
04:00 PM	0	1	0	0	1	33	67	0	0	100	7	1	40	0	48	0	70	3	0	73	0	222	222
04:15 PM	1	0	0	0	1	35	80	0	0	115	2	0	26	0	28	1	57	6	0	64	0	208	208
04:30 PM	0	0	2	0	2	25	76	0	0	101	4	0	38	0	42	1	58	0	0	59	0	204	204
04:45 PM	0	0	2	0	2	33	73	0	0	106	5	0	29	0	34	1	76	5	0	82	0	224	224
Total	1	1	4	0	6	126	296	0	0	422	18	1	133	0	152	3	261	14	0	278	0	858	858
05:00 PM	0	0	2	0	2	42	62	0	0	104	5	1	51	0	57	0	82	5	0	87	0	250	250
05:15 PM	0	0	0	0	0	17	65	0	0	82	5	0	30	0	35	1	69	7	0	77	0	194	194
05:30 PM	1	0	0	0	1	22	63	1	0	86	2	1	34	1	37	0	63	12	0	75	1	199	200
05:45 PM	0	0	3	0	3	23	56	0	0	79	5	0	34	0	39	0	68	4	0	72	0	193	193
Total	1	0	5	0	6	104	246	1	0	351	17	2	149	1	168	1	282	28	0	311	1	836	837
06:00 PM	0	0	0	0	0	34	62	0	0	96	4	0	27	0	31	0	63	6	0	69	0	196	196
06:15 PM	1	0	0	0	1	29	58	0	0	87	3	0	29	0	32	1	68	5	0	74	0	194	194
06:30 PM	1	0	0	0	1	35	65	0	0	100	4	0	42	0	46	0	67	6	0	73	0	220	220
06:45 PM	0	0	1	0	1	11	55	0	0	66	7	0	43	0	50	1	44	1	0	46	0	163	163
Total	2	0	1	0	3	109	240	0	0	349	18	0	141	0	159	2	242	18	0	262	0	773	773
07:00 PM	0	0	0	0	0	33	62	0	0	95	4	1	33	0	38	0	63	3	0	66	0	199	199
07:15 PM	0	0	1	0	1	32	48	0	0	80	2	0	33	0	35	1	52	5	0	58	0	174	174
07:30 PM	0	0	0	0	0	26	53	0	0	79	4	0	24	0	28	0	50	9	0	59	0	166	166
Grand Total	4	1	12	0	17	459	1023	1	0	1483	70	4	547	1	621	11	1024	79	0	1114	1	3235	3236
Approch %	23.5	5.9	70.6			31	69	0.1			11.3	0.6	88.1			1	91.9	7.1					
Total %	0.1	0	0.4		0.5	14.2	31.6	0		45.8	2.2	0.1	16.9		19.2	0.3	31.7	2.4		34.4	0	100	

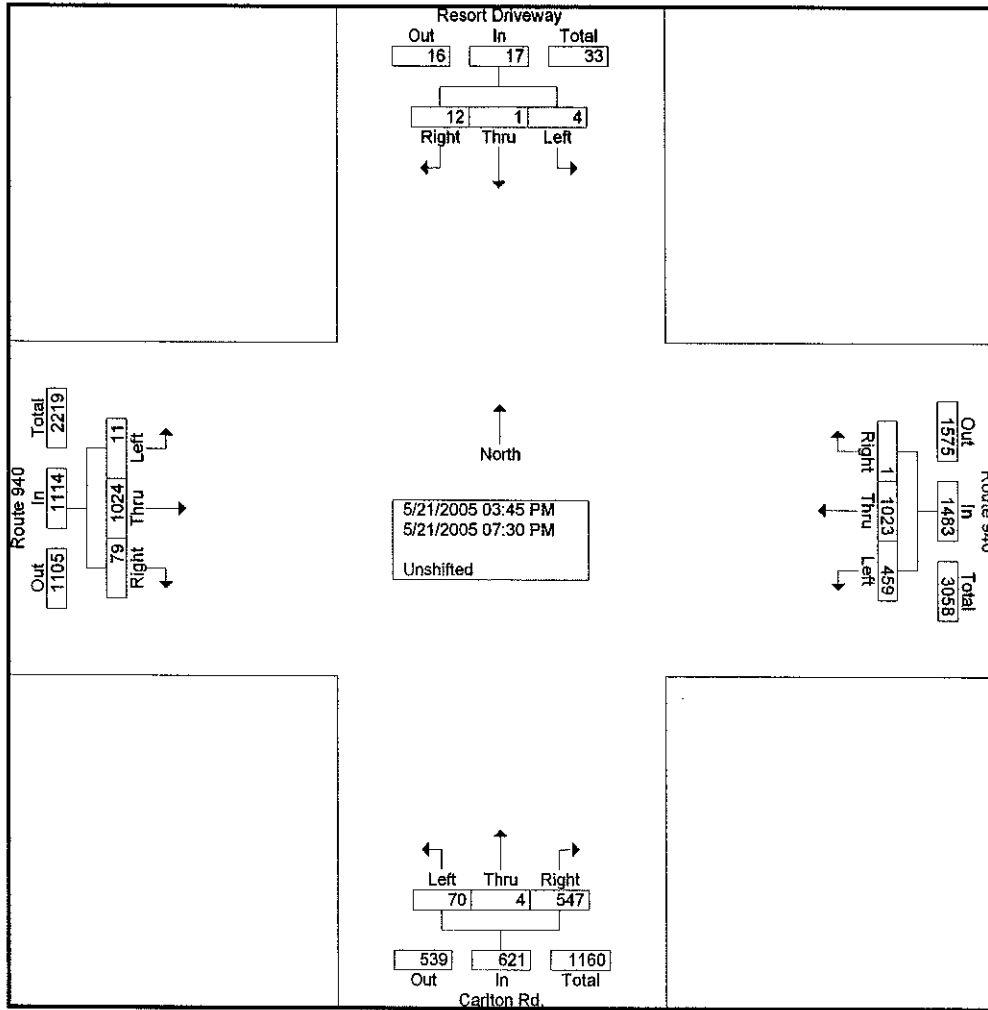

Start Time	Resort Driveway Southbound				Route 940 Westbound				Carlton Rd. Northbound				Route 940 Eastbound				Int. Total
	Left	Thru	Right	App. Total	Left	Thru	Right	App. Total	Left	Thru	Right	App. Total	Left	Thru	Right	App. Total	
Peak Hour Analysis from 03:45 PM to 07:30 PM - Peak 1 of 1																	
Peak Hour for Entire Intersection Begins at 04:15 PM																	
04:15 PM	1	0	0	1	35	80	0	115	2	0	26	28	1	57	6	64	208
04:30 PM	0	0	2	2	25	76	0	101	4	0	38	42	1	58	0	59	204
04:45 PM	0	0	2	2	33	73	0	106	5	0	29	34	1	76	5	82	224
05:00 PM	0	0	2	2	42	62	0	104	5	1	51	57	0	82	5	87	250
Total Volume	1	0	6	7	135	291	0	426	16	1	144	161	3	273	16	292	886
% App. Total	14.3	0	85.7		31.7	68.3	0		9.9	0.6	89.4		1	93.5	5.5		
PHF	.250	.000	.750	.875	.804	.909	.000	.926	.800	.250	.706	.706	.750	.832	.667	.839	.886

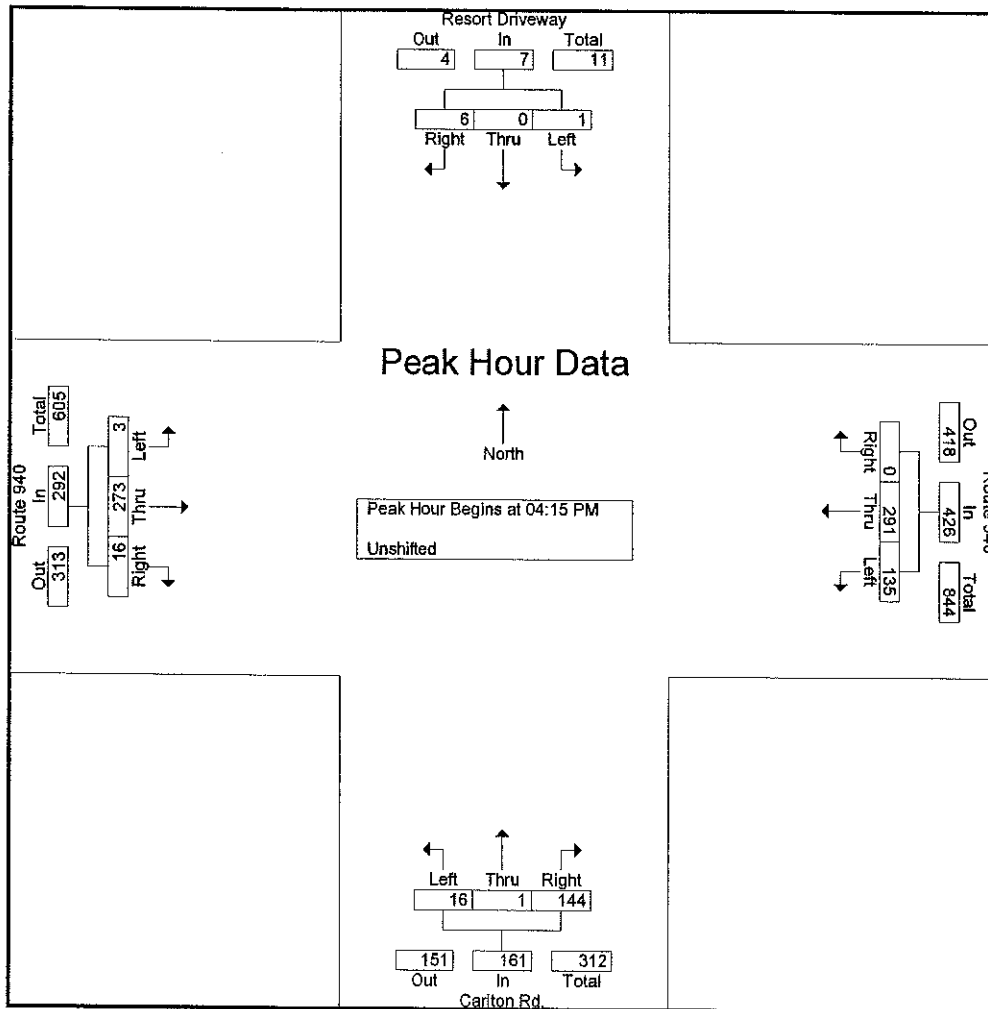

Counter: 30  
 Counted By: C. Kent  
 Weather: clear  
 As: SA390940

File Name : SA390940  
 Site Code : 00000000  
 Start Date : 5/21/2005  
 Page No : 1

Groups Printed- Unshifted

Start Time	Route 390 Southbound					Route 940 Westbound					Northbound					Route 940 Eastbound					Exclu. Total	Inclu. Total	Int. Total
	Left	Thru	Right	Truck	App. Total	Left	Thru	Right	Truck	App. Total	Left	Thru	Right	Truck	App. Total	Left	Thru	Right	Truck	App. Total			
Factor	1.0	1.0	1.0	1.0		1.0	1.0	1.0	1.0		1.0	1.0	1.0	1.0		1.0	1.0	1.0	1.0				
03:00 PM	2	0	67	4	69	0	31	2	1	33	0	0	0	0	0	72	32	0	0	104	5	206	211
03:15 PM	5	0	59	0	64	0	37	4	1	41	0	0	0	0	0	69	31	0	1	100	2	205	207
03:30 PM	1	0	44	2	45	0	35	3	0	38	0	0	0	0	0	59	34	0	2	93	4	176	180
03:45 PM	3	0	51	4	54	0	49	6	1	55	0	0	0	0	0	61	39	0	3	100	8	209	217
Total	11	0	221	10	232	0	152	15	3	167	0	0	0	0	0	261	136	0	6	397	19	796	815
04:00 PM	1	0	48	3	49	0	27	5	0	32	0	0	0	0	0	63	40	0	3	103	6	184	190
04:15 PM	3	0	51	1	54	0	41	1	0	42	0	0	0	0	0	52	38	0	0	90	1	186	187
04:30 PM	1	0	46	0	47	0	44	1	1	45	0	0	0	0	0	54	45	0	2	99	3	191	194
04:45 PM	18	0	59	1	77	0	47	3	1	50	0	0	0	0	0	45	53	0	1	98	3	225	228
Total	23	0	204	5	227	0	159	10	2	169	0	0	0	0	0	214	176	0	6	390	13	786	799
05:00 PM	6	0	73	2	79	0	27	3	2	30	0	0	0	0	0	81	53	0	8	134	12	243	255
05:15 PM	3	0	40	1	43	0	33	4	1	37	0	0	0	0	0	55	39	0	1	94	3	174	177
05:30 PM	1	0	33	0	34	0	33	2	0	35	0	0	0	0	0	58	32	0	0	90	0	159	159
05:45 PM	6	0	50	1	56	0	27	8	3	35	0	0	0	0	0	62	43	0	3	105	7	196	203
Total	16	0	196	4	212	0	120	17	6	137	0	0	0	0	0	256	167	0	12	423	22	772	794
06:00 PM	0	0	46	4	46	0	39	1	1	40	0	0	0	0	0	52	32	0	1	84	6	170	176
06:15 PM	0	0	44	0	44	0	35	5	1	40	0	0	0	0	0	47	45	0	1	92	2	176	178
06:30 PM	0	0	50	2	50	0	39	17	0	56	0	0	0	0	0	67	40	0	1	107	3	213	216
06:45 PM	1	0	23	1	24	0	47	6	0	53	0	0	0	0	0	54	42	0	0	96	1	173	174
Total	1	0	163	7	164	0	160	29	2	189	0	0	0	0	0	220	159	0	3	379	12	732	744
Grand Total	51	0	784	26	835	0	591	71	13	662	0	0	0	0	0	951	638	0	27	1589	66	3086	3152
Apprch %	6.1	0	93.9			0	89.3	10.7			0	0	0			59.8	40.2	0					
Total %	1.7	0	25.4		27.1	0	19.2	2.3		21.5	0	0	0		0	30.8	20.7	0		51.5	2.1	97.9	

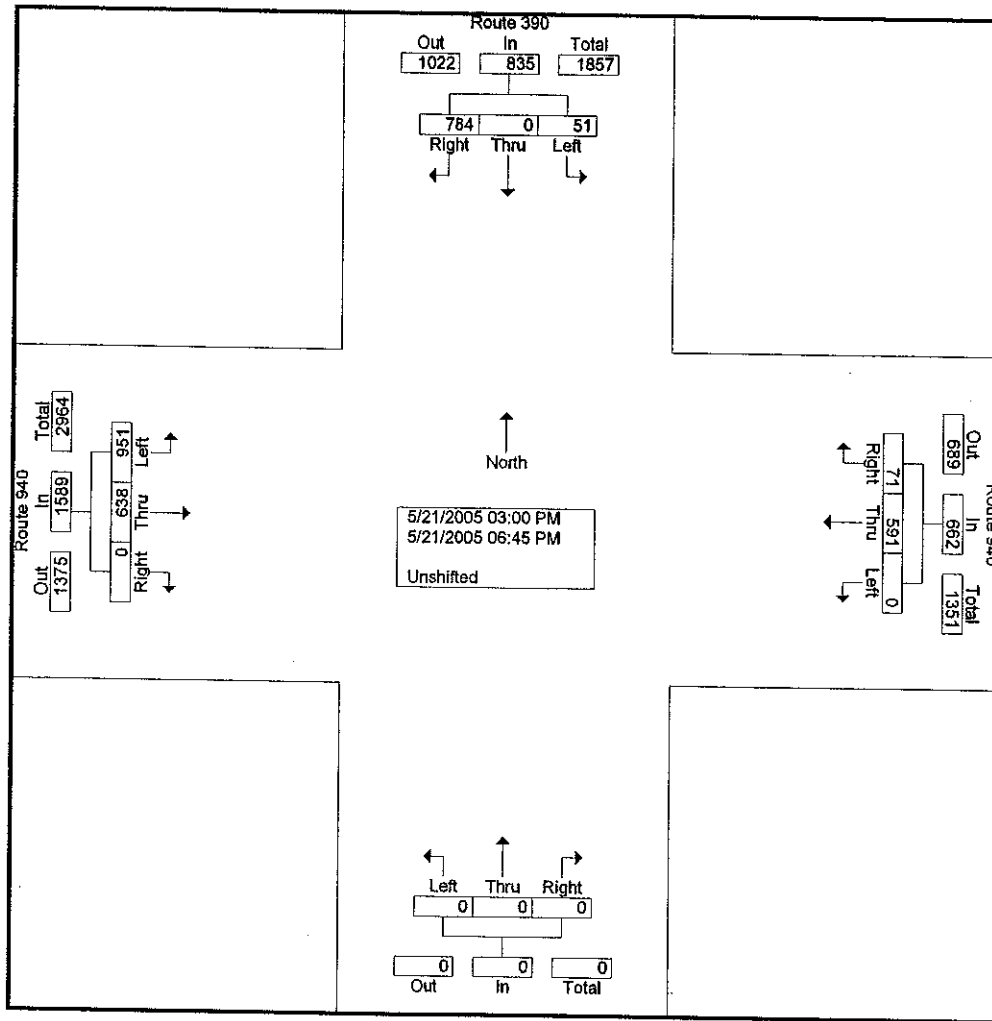



Start Time	Route 390 Southbound				Route 940 Westbound				Northbound				Route 940 Eastbound				Int. Total
	Left	Thru	Right	App. Total	Left	Thru	Right	App. Total	Left	Thru	Right	App. Total	Left	Thru	Right	App. Total	
Peak Hour Analysis From 03:00 PM to 06:45 PM - Peak 1 of 1																	
Peak Hour for Entire Intersection Begins at 04:15 PM																	
04:15 PM	3	0	51	54	0	41	1	42	0	0	0	0	52	38	0	90	186
04:30 PM	1	0	46	47	0	44	1	45	0	0	0	0	54	45	0	99	191
04:45 PM	18	0	59	77	0	47	3	50	0	0	0	0	45	53	0	98	225
05:00 PM	6	0	73	79	0	27	3	30	0	0	0	0	81	53	0	134	243
Total Volume	28	0	229	257	0	159	8	167	0	0	0	0	232	189	0	421	845
% App. Total	10.9	0	89.1		0	95.2	4.8		0	0	0		55.1	44.9	0		
PHF	.389	.000	.784	.813	.000	.846	.667	.835	.000	.000	.000	.000	.716	.892	.000	.785	.869

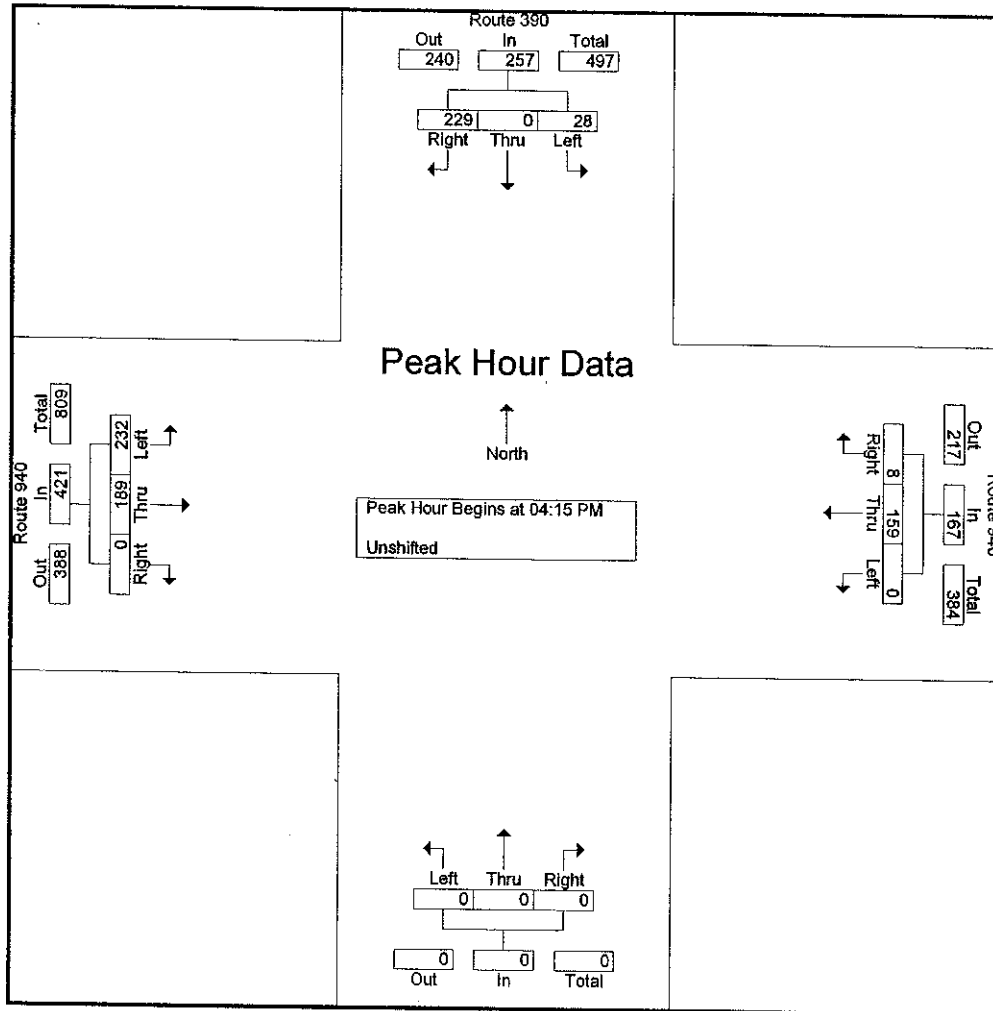

Traffic Planning & Design, Inc.  
 2500 E. High St. Suite 650  
 Pottstown, PA 19464  
**Route 940 & Route 191/Red Rock Rd.**

Counter: IMC 001  
 Counted By: C. Kent  
 Weather: overcast  
 SAs: SA191940

File Name : SA191940  
 Site Code : 00011111  
 Start Date : 6/18/2005  
 Page No : 1

**Groups Printed- Unshifted**

Start Time	Route 191 Southbound					Route 191 Westbound					Red Rock Rd. Northbound					Route 940 Eastbound					Excl. Total	Incl. Total	Int. Total	
	Factor	Left	Thru	Right	Truck	App. Total	Left	Thru	Right	Truck	App. Total	Left	Thru	Right	Truck	App. Total	Left	Thru	Right	Truck				App. Total
03:00 PM	33	4	7	1	44	0	18	19	0	37	1	1	0	0	2		6	31	1	1	38			
03:15 PM	9	4	6	0	19	0	27	24	0	51	0	0	0	0	0		5	24	1	2	30	2	121	123
03:30 PM	21	0	5	1	26	0	29	22	1	51	0	0	1	0	1		7	27	0	0	34	2	100	102
03:45 PM	21	0	3	0	24	0	17	23	0	40	0	1	1	0	2		5	23	0	0	28	2	112	114
Total	84	8	21	2	113	0	91	88	1	179	1	2	2	0	5		23	105	2	3	130	6	94	94
04:00 PM	9	1	4	0	14	2	39	14	2	55	0	1	0	0	1		8	31	3	2	42	0	427	433
04:15 PM	16	5	6	0	27	2	43	21	2	66	1	1	1	0	3		4	38	0	0	42	4	112	116
04:30 PM	9	0	4	0	13	0	40	19	0	59	0	0	1	0	1		8	18	0	1	26	2	138	140
04:45 PM	17	3	9	0	29	0	41	16	1	57	1	3	1	0	5		15	29	1	1	45	1	99	100
Total	51	9	23	0	83	4	163	70	5	237	2	5	3	0	10		35	116	4	4	155	2	136	138
05:00 PM	17	0	7	1	24	0	27	9	1	36	0	0	0	0	0		3	33	1	0	37	9	485	494
05:15 PM	11	4	6	1	21	1	40	17	1	58	2	1	1	0	4		5	37	2	2	44	2	112	116
05:30 PM	19	4	5	0	28	3	40	24	2	67	0	0	0	0	0		3	31	0	1	34	4	127	131
05:45 PM	23	2	0	2	25	0	28	18	0	46	0	1	0	0	1		4	31	2	0	37	3	129	132
Total	70	10	18	4	98	4	135	68	4	207	2	2	1	0	5		15	132	5	3	152	11	109	111
06:00 PM	18	0	1	0	19	1	22	11	0	34	2	1	2	2	5		6	36	0	0	42	2	462	473
06:15 PM	10	5	11	1	26	0	27	18	1	45	0	4	1	0	5		9	29	1	0	39	2	100	102
06:30 PM	20	1	7	1	28	1	23	15	0	39	1	8	0	0	9		7	24	1	0	32	2	115	117
06:45 PM	14	1	7	0	22	0	24	13	0	37	0	1	1	0	2		6	24	1	1	31	1	108	109
Total	62	7	26	2	95	2	96	57	1	155	3	14	4	2	21		28	113	3	1	144	1	92	93
Total	267	34	88	8	389	10	485	283	11	778	8	23	10	2	41		101	466	14	11	581	6	415	421
prch %	68.6	8.7	22.6			1.3	62.3	36.4			19.5	56.1	24.4				17.4	80.2	2.4			32	1789	1821
Total %	14.9	1.9	4.9		21.7	0.6	27.1	15.8		43.5	0.4	1.3	0.6		2.3		5.6	26	0.8		32.5	1.8	98.2	

Traffic Planning & Design, Inc.  
 2500 E. High St. Suite 650  
 Pottstown, PA 19464  
**Route 940 & Route 191/Red Rock Rd.**

File Name : SA191940  
 Site Code : 00011111  
 Start Date : 6/18/2005  
 Page No : 2

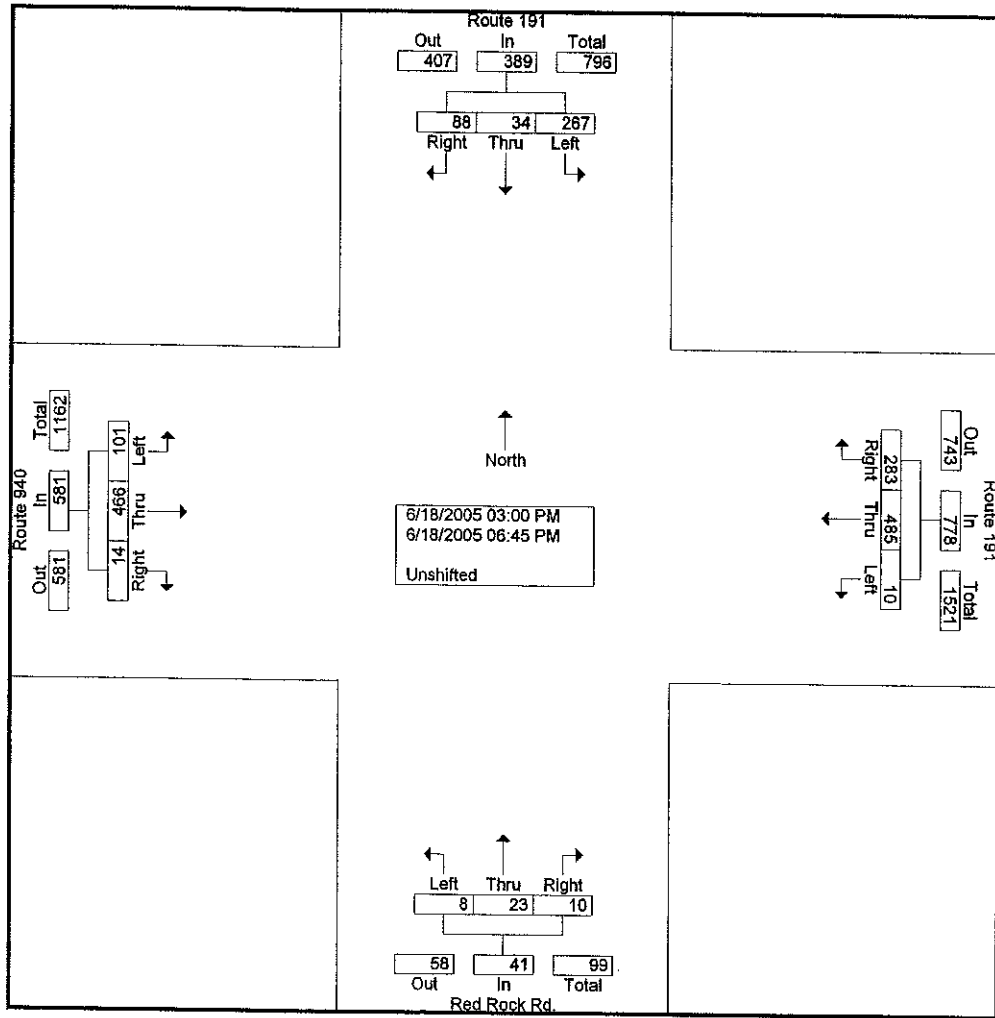

Traffic Planning & Design, Inc.  
 2500 E. High St. Suite 650  
 Pottstown, PA 19464  
**Route 940 & Route 191/Red Rock Rd.**

File Name : SA191940  
 Site Code : 00011111  
 Start Date : 6/18/2005  
 Page No : 3

Start Time	Route 191 Southbound				Route 191 Westbound				Red Rock Rd. Northbound				Route 940 Eastbound				Int. Total
	Left	Thru	Right	App. Total	Left	Thru	Right	App. Total	Left	Thru	Right	App. Total	Left	Thru	Right	App. Total	
Peak Hour Analysis from 03:00 PM to 06:45 PM - Peak 1 of 1																	
Peak Hour for Entire Intersection Begins at 04:45 PM																	
04:45 PM	17	3	9	29	0	41	16	57	1	3	1	5	15	29	1	45	136
05:00 PM	17	0	7	24	0	27	9	36	0	0	0	0	3	33	1	37	97
05:15 PM	11	4	6	21	1	40	17	58	2	1	1	4	5	37	2	44	127
05:30 PM	19	4	5	28	3	40	24	67	0	0	0	0	3	31	0	34	129
Total Volume	64	11	27	102	4	148	66	218	3	4	2	9	26	130	4	160	489
% App. Total	62.7	10.8	26.5		1.8	67.9	30.3		33.3	44.4	22.2		16.2	81.2	2.5		
PHF	.842	.688	.750	.879	.333	.902	.688	.813	.375	.333	.500	.450	.433	.878	.500	.889	.899

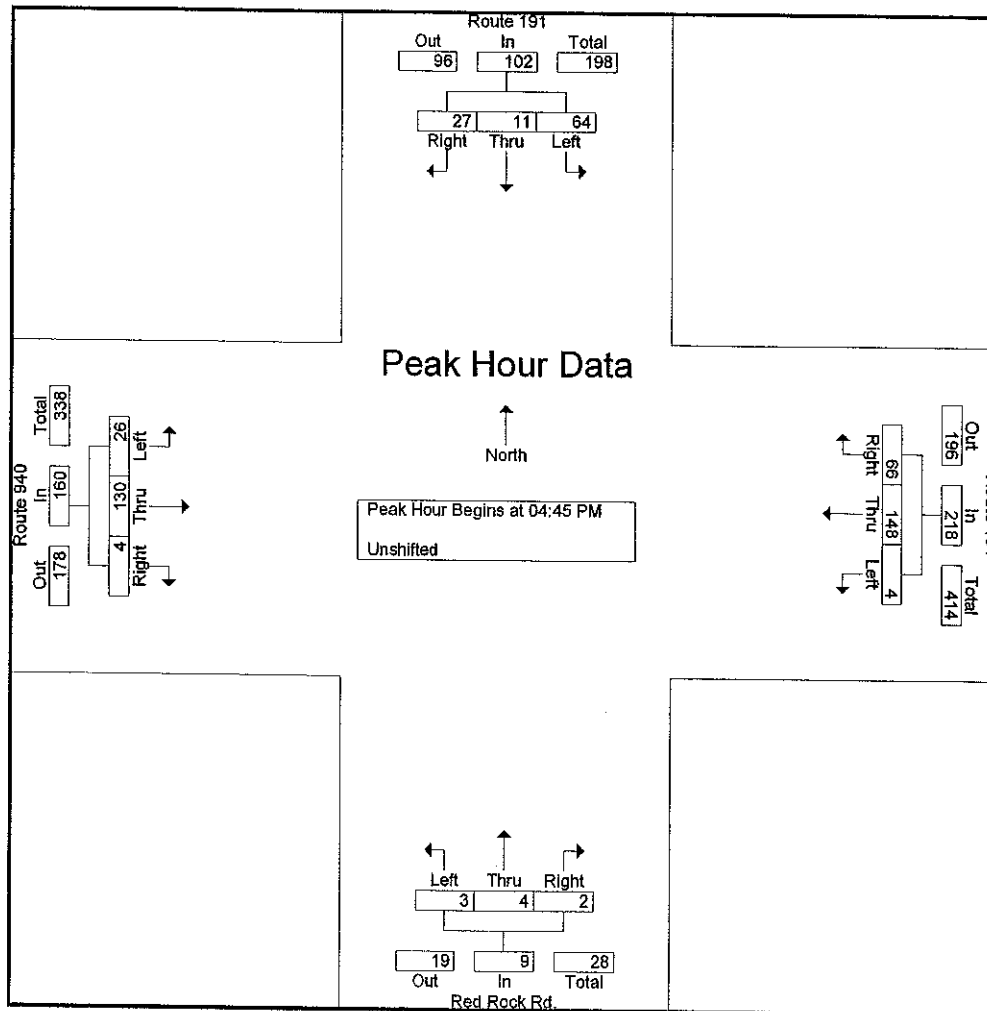

***ITMS DATA SHEETS***



Close



SITE NO: 14129

<b>County</b>	<b>Route</b>	<b>Dir</b>	<b>Current Average Daily Traffic</b>	<b>Current Average Daily Truck Volume</b>
MONROE (45)	0611	N	6707	671
<b>K Factor</b>	<b>D Factor</b>	<b>T Factor</b>	<b>Truck Percent</b>	<b>Base Traffic Year</b>
8	50	5	10	2003

Traffic Pattern Group  
NORTH RURAL - MINOR ARTERIALS



Fast(Cable, T1, DSL)  Slow (Dial-up)



Close



SITE NO: 14129

County	Route	Dir	Current Average Daily Traffic	Current Average Daily Truck Volume
MONROE (45)	0611	S	7983	798
K Factor 8	D Factor 50	T Factor 5	Truck Percent 10	Base Traffic Year 2003

Traffic Pattern Group  
CENTRAL RURAL- MINOR ARTERIALS



Fast(Cable, T1, DSL)  Slow (Dial-up)



Close



SITE NO: 6914

<b>County</b>	<b>Route</b>	<b>Dir</b>	<b>Current Average Daily Traffic</b>	<b>Current Average Daily Truck Volume</b>
MONROE (45)	1013	B	2552	255
<b>K Factor</b>	<b>D Factor</b>	<b>T Factor</b>	<b>Truck Percent</b>	<b>Base Traffic Year</b>
12	55	5	10	2002

Traffic Pattern Group  
NORTH RURAL - COLLECTORS AND LOCAL ROADS



Fast(Cable, T1, DSL)  Slow (Dial-up)





Close



SITE NO: 37994

<b>County</b>	<b>Route</b>	<b>Dir</b>	<b>Current Average Daily Traffic</b>	<b>Current Average Daily Truck Volume</b>
MONROE (45)	0314	B	546	55
<b>K Factor</b>	<b>D Factor</b>	<b>T Factor</b>	<b>Truck Percent</b>	<b>Base Traffic Year</b>
12	55	5	10	1999

Traffic Pattern Group  
CENTRAL RURAL- COLLECTORS AND LOCAL ROADS



Fast(Cable, T1, DSL)  Slow (Dial-up)



Close



SITE NO: 13385

<b>County</b>	<b>Route</b>	<b>Dir</b>	<b>Current Average Daily Traffic</b>	<b>Current Average Daily Truck Volume</b>
MONROE (45)	0314	B	3529	106
<b>K Factor</b>	<b>D Factor</b>	<b>T Factor</b>	<b>Truck Percent</b>	<b>Base Traffic Year</b>
11	55	2	3	2003

Traffic Pattern Group  
CENTRAL RURAL- COLLECTORS AND LOCAL ROADS



Fast(Cable, T1, DSL)  Slow (Dial-up)



Close



SITE NO: 3809

County	Route	Dir	Current Average Daily Traffic	Current Average Daily Truck Volume
MONROE (45)	1011	B	3268	169
K Factor	D Factor	T Factor	Truck Percent	Base Traffic Year
10	60	5	5	2004

Traffic Pattern Group  
CENTRAL RURAL- COLLECTORS AND LOCAL ROADS



Fast(Cable, T1, DSL)  Slow (Dial-up)



Close



SITE NO: 6980

County	Route	Dir	Current Average Daily Traffic	Current Average Daily Truck Volume
MONROE (45)	0940	B	7769	388
K Factor	D Factor	T Factor	Truck Percent	Base Traffic Year
12	55	3	5	2001

Traffic Pattern Group  
NORTH RURAL - MINOR ARTERIALS



Fast(Cable, T1, DSL)  Slow (Dial-up)



Close



SITE NO: 13661

<b>County</b>	<b>Route</b>	<b>Dir</b>	<b>Current Average Daily Traffic</b>	<b>Current Average Daily Truck Volume</b>
MONROE (45)	0390	B	7124	510
<b>K Factor</b>	<b>D Factor</b>	<b>T Factor</b>	<b>Truck Percent</b>	<b>Base Traffic Year</b>
10	55	8	7	2004
<b>Traffic Pattern Group</b>				
NORTH RURAL - MINOR ARTERIALS				



Fast(Cable, T1, DSL)  Slow (Dial-up)



Close



SITE NO: 6900

<b>County</b>	<b>Route</b>	<b>Dir</b>	<b>Current Average Daily Traffic</b>	<b>Current Average Daily Truck Volume</b>
MONROE (45)	0191	B	2377	71
<b>K Factor</b>	<b>D Factor</b>	<b>T Factor</b>	<b>Truck Percent</b>	<b>Base Traffic Year</b>
12	55	2	3	2002

Traffic Pattern Group  
NORTH RURAL - MINOR ARTERIALS



Fast(Cable, T1, DSL)  Slow (Dial-up)

***APPENDIX C***  
***TRIP DISTRIBUTIONS:***  
***NEARBY PLANNED DEVELOPMENT***

FRIDAY P.M. PEAK HOUR

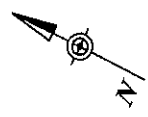
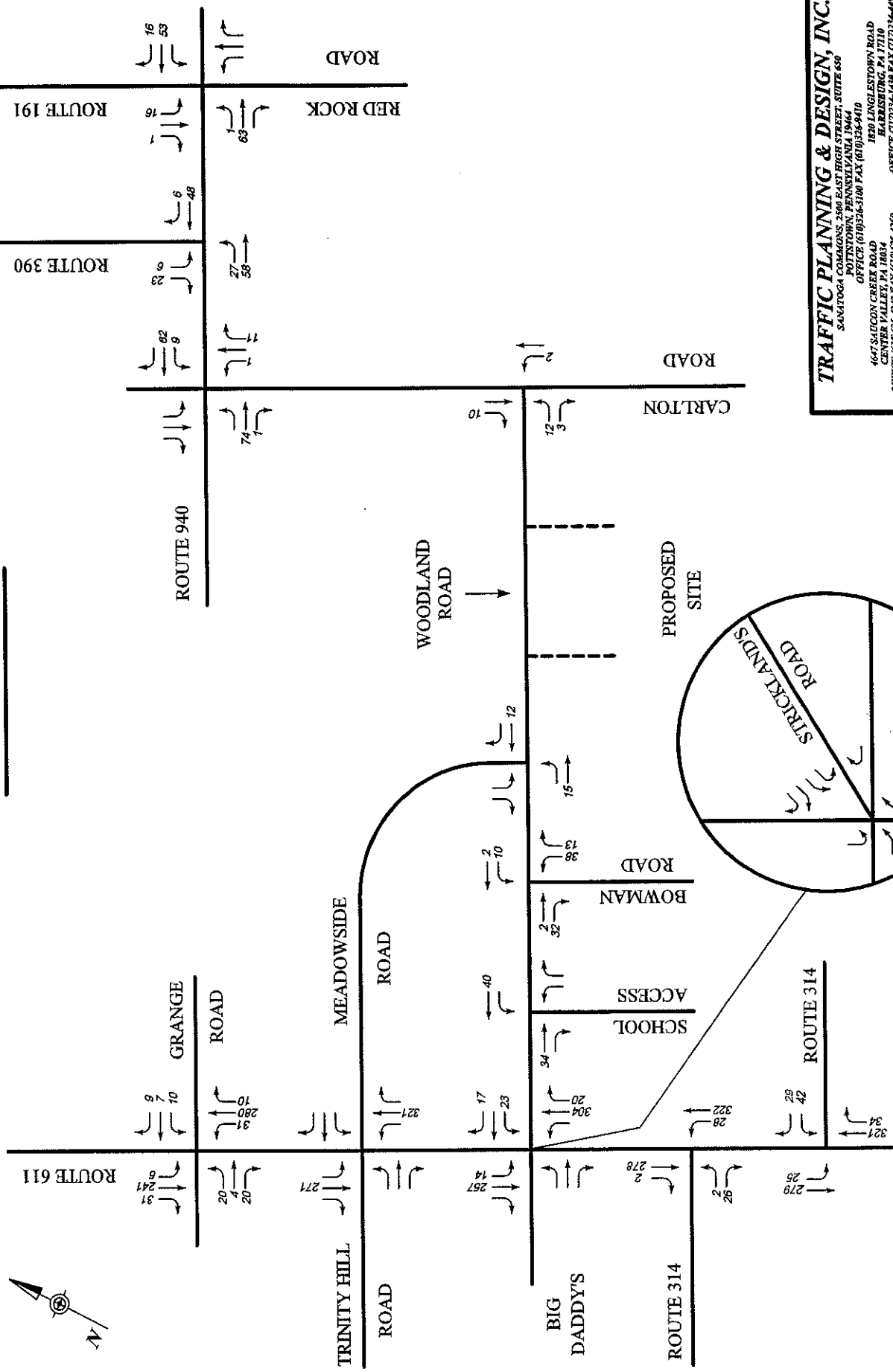

**TRAFFIC PLANNING & DESIGN, INC.**  
 SAMITOGA COMMONS, 280 EAST HIGHWAY TRAIL, SUITE 650  
 HARRISBURG, PA 17110  
 OFFICE (717) 234-1100 FAX (717) 234-9410  
 467 S. LOGY CREEK ROAD  
 HARRISBURG, PA 17110  
 OFFICE (717) 234-1259 FAX (717) 234-4490  
 E-MAIL TRAFFICEXPERTS@TRAFFICPD.COM

FIGURE C-1  
 NEARBY PLANNED DEVELOPMENTS  
 FRIDAY P.M. PEAK HOUR

LEGEND:  
 - - - - = PROPOSED SITE DRIVEWAY  
 SCHEMATIC DRAWING; NOT TO SCALE



SATURDAY P.M. PEAK HOUR

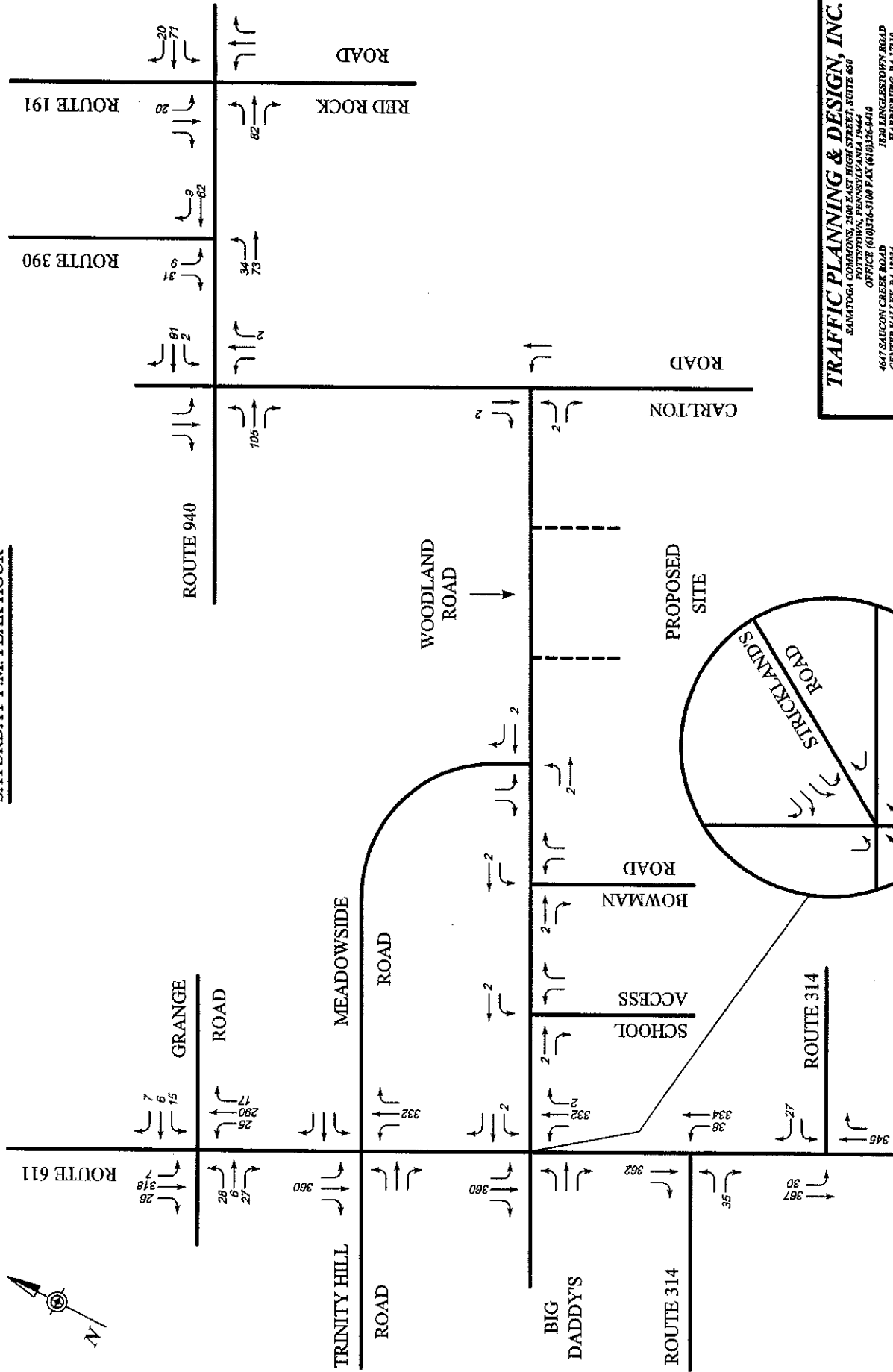

**TRAFFIC PLANNING & DESIGN, INC.**  
 SAMATOGA COMMONS, 2500 EAST HIGH STREET, SUITE 650  
 POTTSTOWN, PENNSYLVANIA 19464  
 OFFICE (610) 726-3100 FAX (610) 266-9410  
 1629 LENGLESTOWN ROAD  
 CENTER VALLEY, PA 18834  
 OFFICE (717) 254-4400 FAX (717) 254-4490  
 E-MAIL: TRAFFICPEPERS@TRAFFICPD.COM

**FIGURE C-2**

NEARBY PLANNED DEVELOPMENTS  
 SATURDAY P.M. PEAK HOUR

**LEGEND:**  
 - - - - - = PROPOSED SITE DRIVEWAY  
 SCHEMATIC DRAWING: NOT TO SCALE

FRIDAY P.M. PEAK HOUR

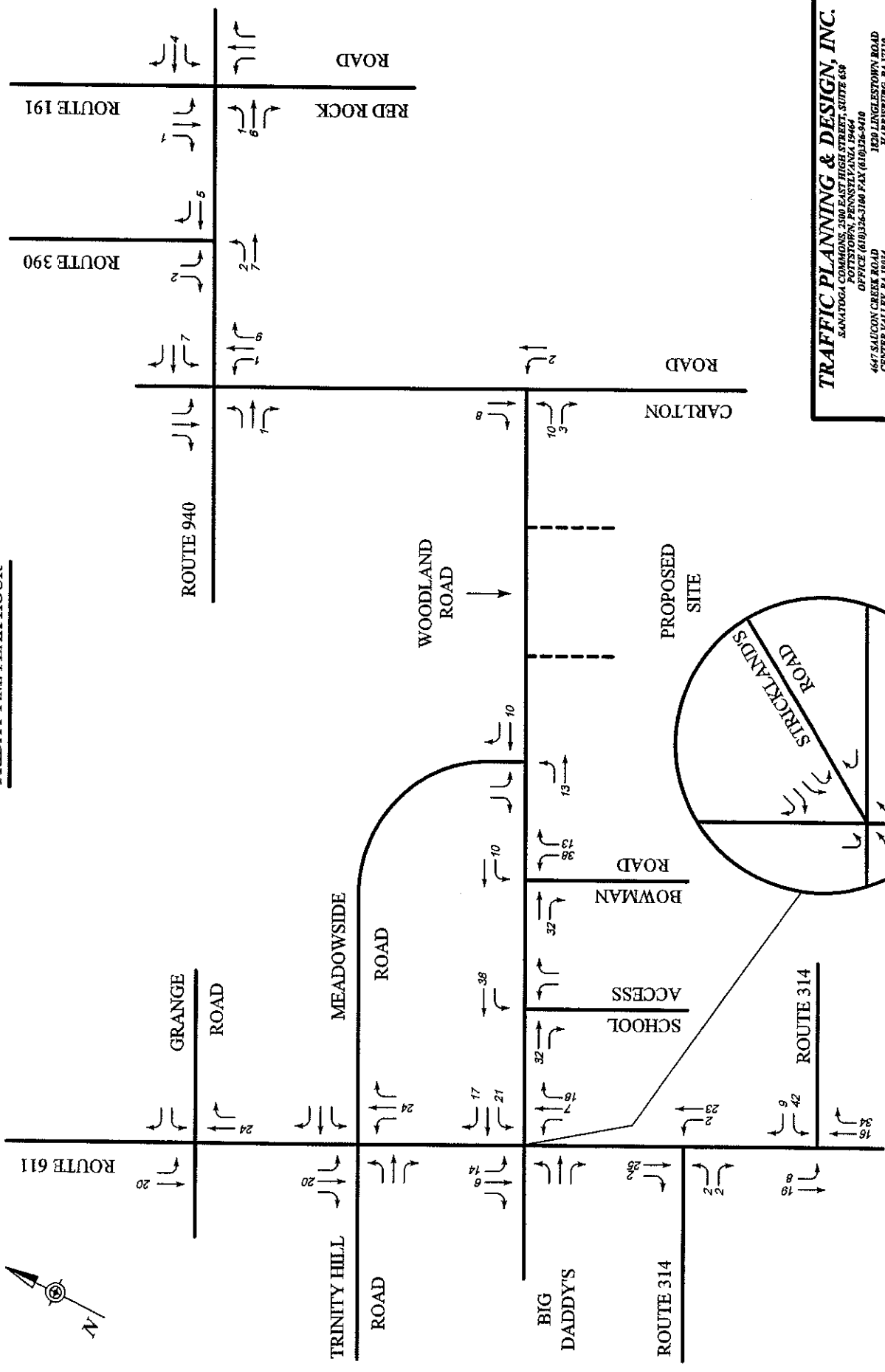

LEGEND:

- - - - - = PROPOSED SITE DRIVEWAY
- SCHEMATIC DRAWING: NOT TO SCALE

**TRAFFIC PLANNING & DESIGN, INC.**  
 300 W. 10TH STREET, SUITE 600  
 POTTSTOWN, PENNSYLVANIA 19444  
 OFFICE (610) 324-3100 FAX (610) 324-8410  
 467 SAUCON CREEK ROAD  
 100 LINGLESTOWN ROAD  
 CENTER VALLEY, PA 16834 HARRISBURG, PA 17110  
 OFFICE (610) 625-4242 FAX (610) 625-4330 OFFICE (717) 334-1300 FAX (717) 334-4990  
 E-MAIL: TRAFFICEXPERTS@TRAFFICPD.COM

FIGURE C-3

POCONO MOUNTAIN ELEMENTARY  
 FRIDAY P.M. PEAK HOUR

FRIDAY P.M. PEAK HOUR

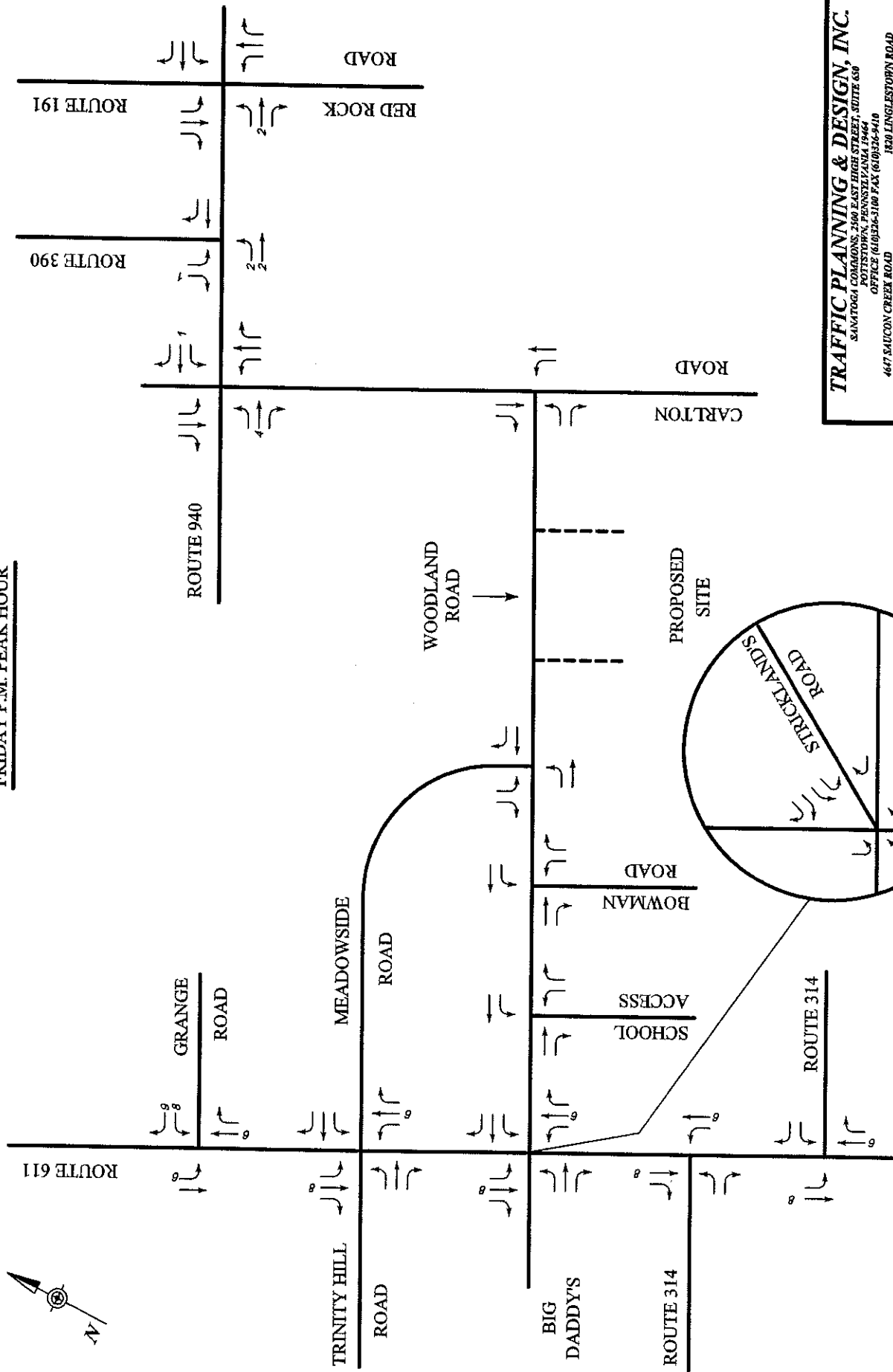

LEGEND:  
 - - - - - PROPOSED SITE DRIVEWAY  
 SCHEMATIC DRAWING: NOT TO SCALE

**TRAFFIC PLANNING & DESIGN, INC.**  
 1820 LINGESTOWN ROAD  
 HARRISBURG, PA 17110  
 OFFICE (717) 334-4250  
 E-MAIL: TRAFFICEXPERTS@TRAFFICPD.COM

FIGURE C-4

TALL OAKS  
 FRIDAY P.M. PEAK HOUR

SATURDAY P.M. PEAK HOUR

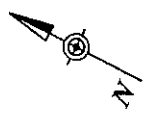
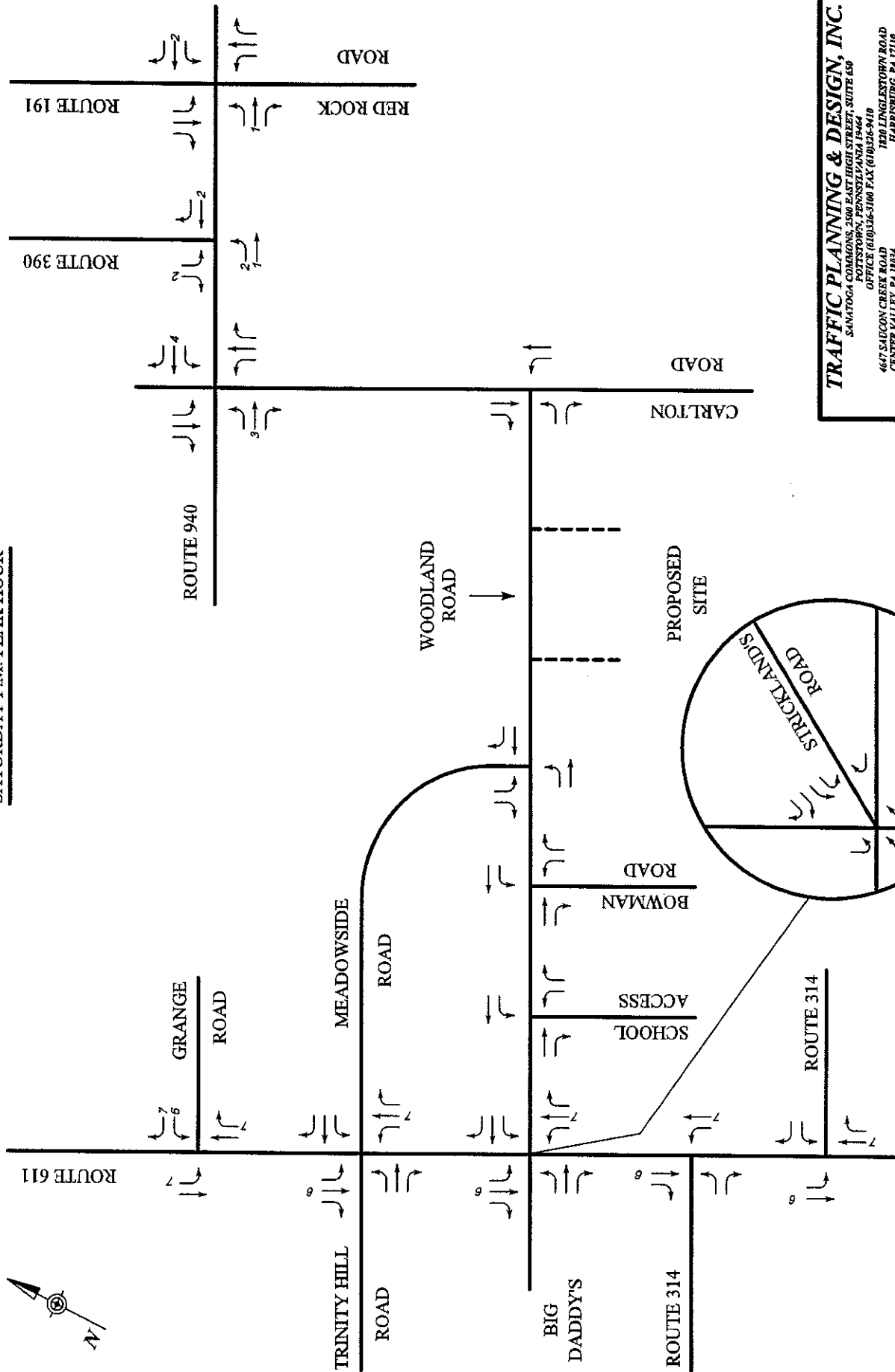

**TRAFFIC PLANNING & DESIGN, INC.**  
 SANATOGA COMMONS, 280 EAST HIGH STREET, SUITE 430  
 POTTSVILLE, PENNSYLVANIA 19464  
 OFFICE (610)326-3100 FAX (610)326-5410  
 467 SAUCON CREEK ROAD  
 CENTER VALLEY, PA 16834  
 OFFICE (717)234-1438 FAX (717)234-4990  
 E-MAIL: TRAFFICEXPERTS@TRAFFICPD.COM

**FIGURE C-5**  
 TALL OAKS  
 SATURDAY P.M. PEAK HOUR

**LEGEND:**  
 - - - - - = PROPOSED SITE DRIVEWAY  
 SCHEMATIC DRAWING: NOT TO SCALE

FRIDAY P.M. PEAK HOUR

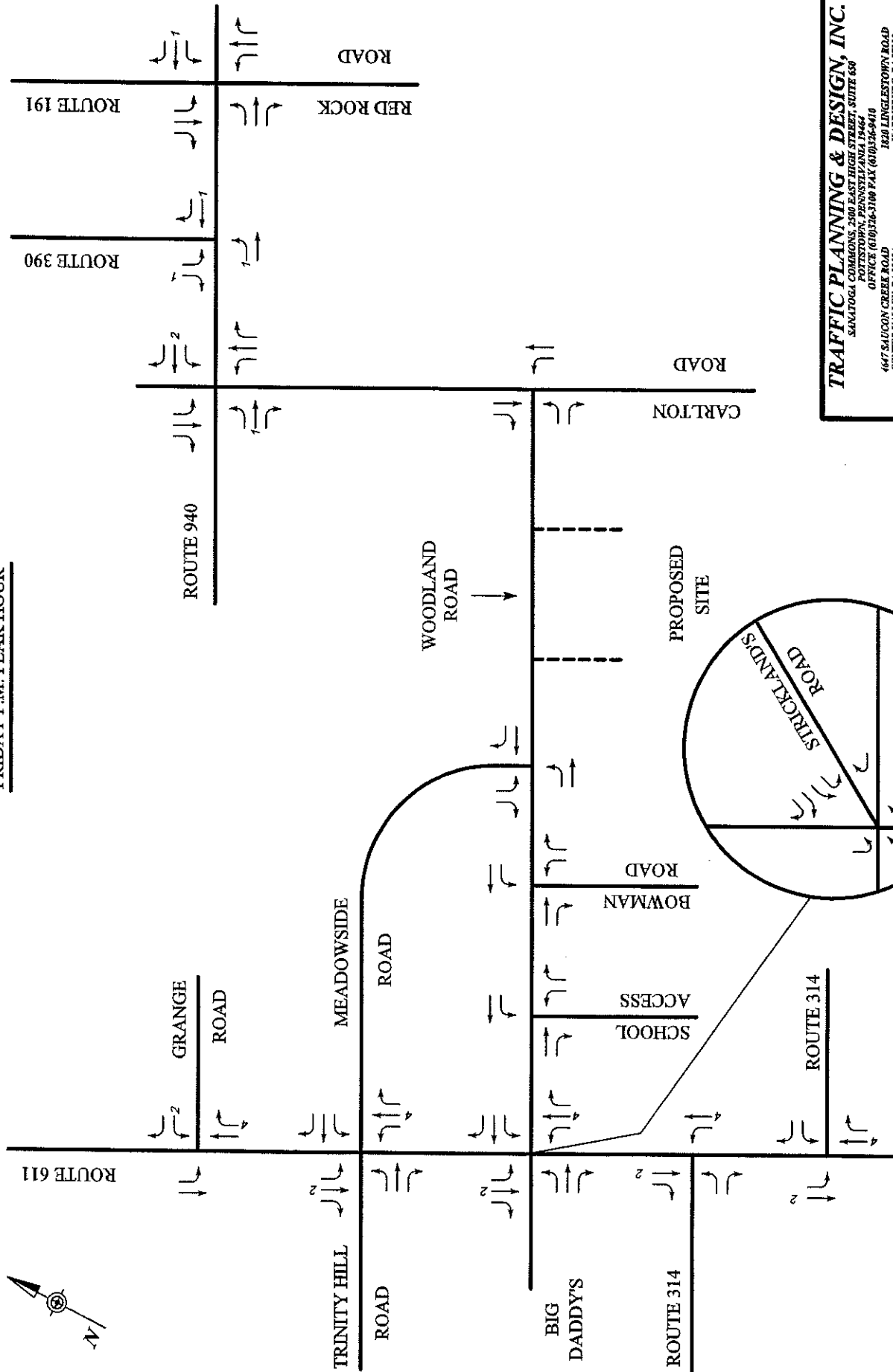

LEGEND:  
 - - - - - = PROPOSED SITE DRIVEWAY  
 SCHEMATIC DRAWING: NOT TO SCALE

**TRAFFIC PLANNING & DESIGN, INC.**  
 SAVATOGA COMMONS, 200 EAST HIGH STREET, SUITE 400  
 POITSTOWN, PENNSYLVANIA 19464  
 OFFICE (610)376-3100 FAX (610)376-9410  
 467 SALUCON CREEK ROAD  
 CENTER VALLEY, PA 18854  
 OFFICE (610)611-2942 FAX (610)611-2550  
 E-MAIL TRAFFICEXPERTS@TRAFFICPD.COM

FIGURE C-6

GRANGE/940 RESIDENTIAL  
 FRIDAY P.M. PEAK HOUR

SATURDAY P.M. PEAK HOUR

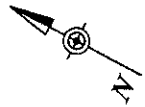
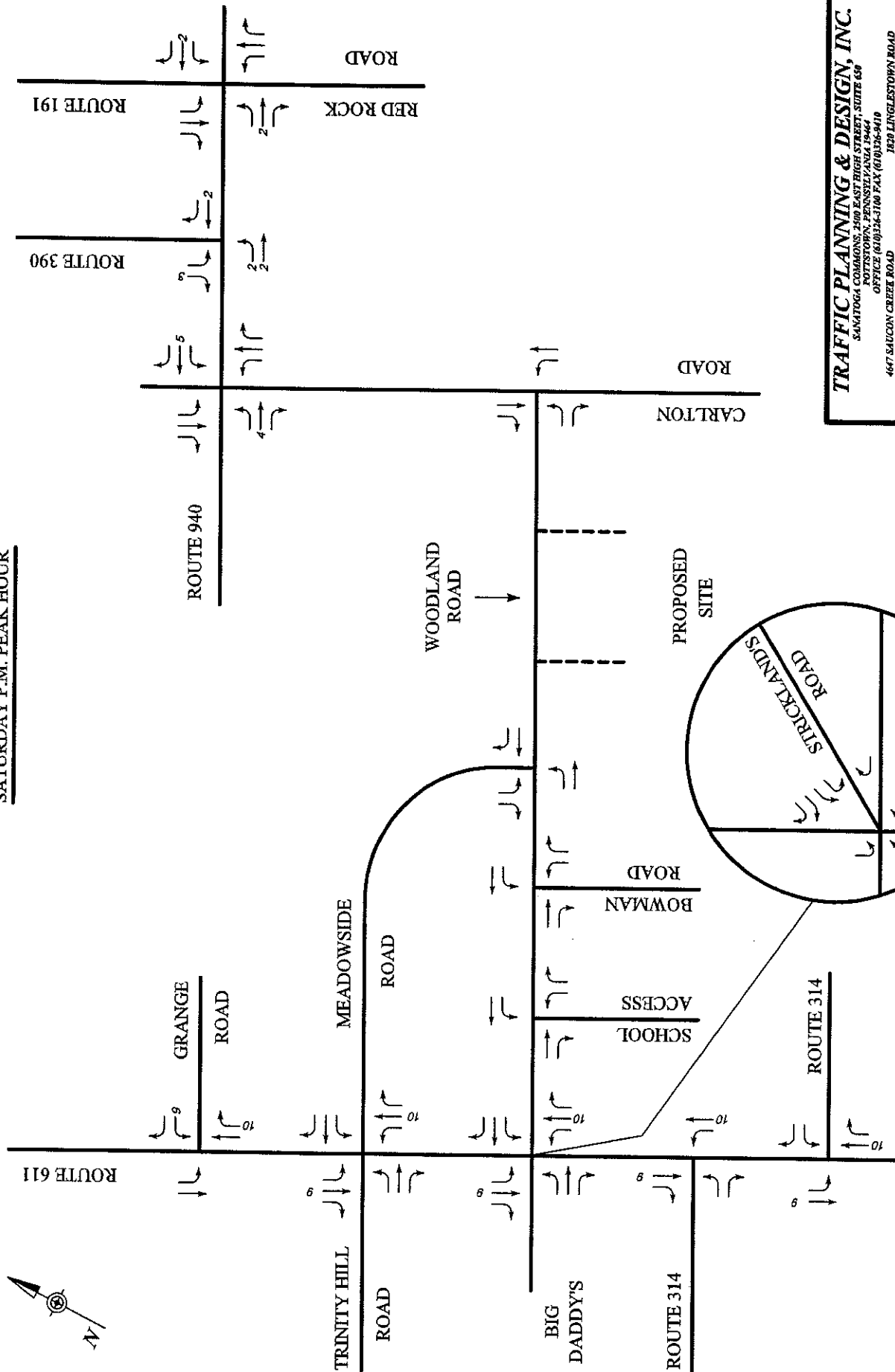

**TRAFFIC PLANNING & DESIGN, INC.**  
SANGATONG COMMONS, 2500 EAST HIGH STREET, SUITE 630  
POTTSTOWN, PENNSYLVANIA 19464  
OFFICE (610)324-3100 FAX (610)326-9410  
1820 LINGLESTOWN ROAD  
HARRISBURG, PA 17110  
OFFICE (610)651-4343 FAX (610)651-4250  
E-MAIL: TRAFFICEXPERTS@TRAFFICPD.COM

FIGURE C-7

GRANGE/940 RESIDENTIAL  
SATURDAY P.M. PEAK HOUR

LEGEND:  
- - - - - PROPOSED SITE DRIVEWAY  
SCHEMATIC DRAWING: NOT TO SCALE

FRIDAY P.M. PEAK HOUR

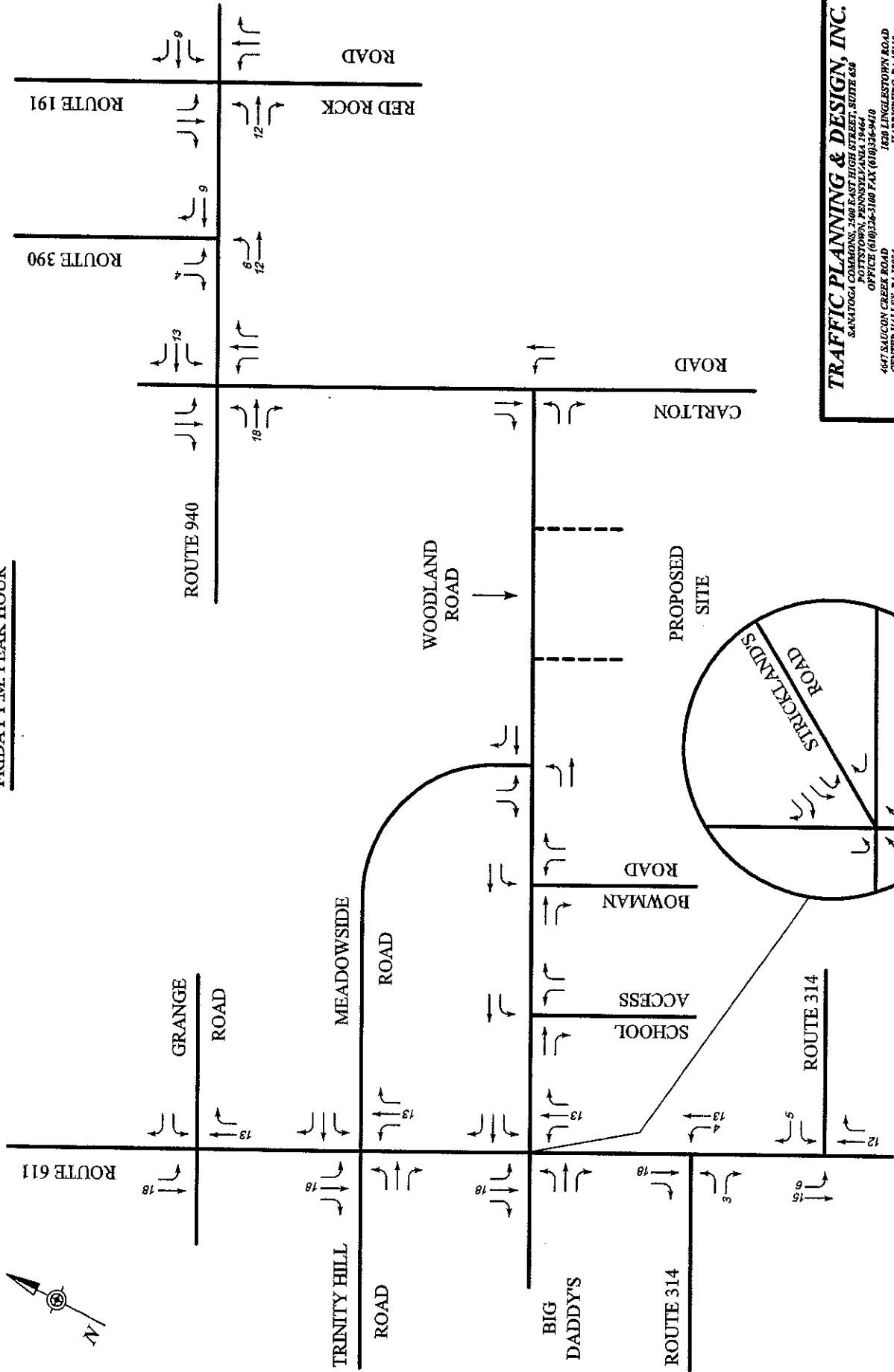

LEGEND:  
 - - - - - = PROPOSED SITE DRIVEWAY  
 SCHEMATIC DRAWING: NOT TO SCALE

**TRAFFIC PLANNING & DESIGN, INC.**  
 SAVATOGA COMMONS, 2500 EAST HIGH STREET, SUITE 638  
 POTTSTOWN, PENNSYLVANIA 19464  
 OFFICE (610) 266-3100 FAX (610) 936-9470  
 447 SAUCON CREEK ROAD  
 CENTER ALLEY, #1000  
 HARRISBURG, PA 17110  
 OFFICE (717) 254-1668 FAX (717) 244-4690  
 E-MAIL: TRAFFICEXPERTS@TRAFFICPD.COM

FIGURE C-8  
 LOWE'S  
 FRIDAY P.M. PEAK HOUR

SATURDAY P.M. PEAK HOUR

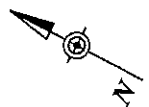
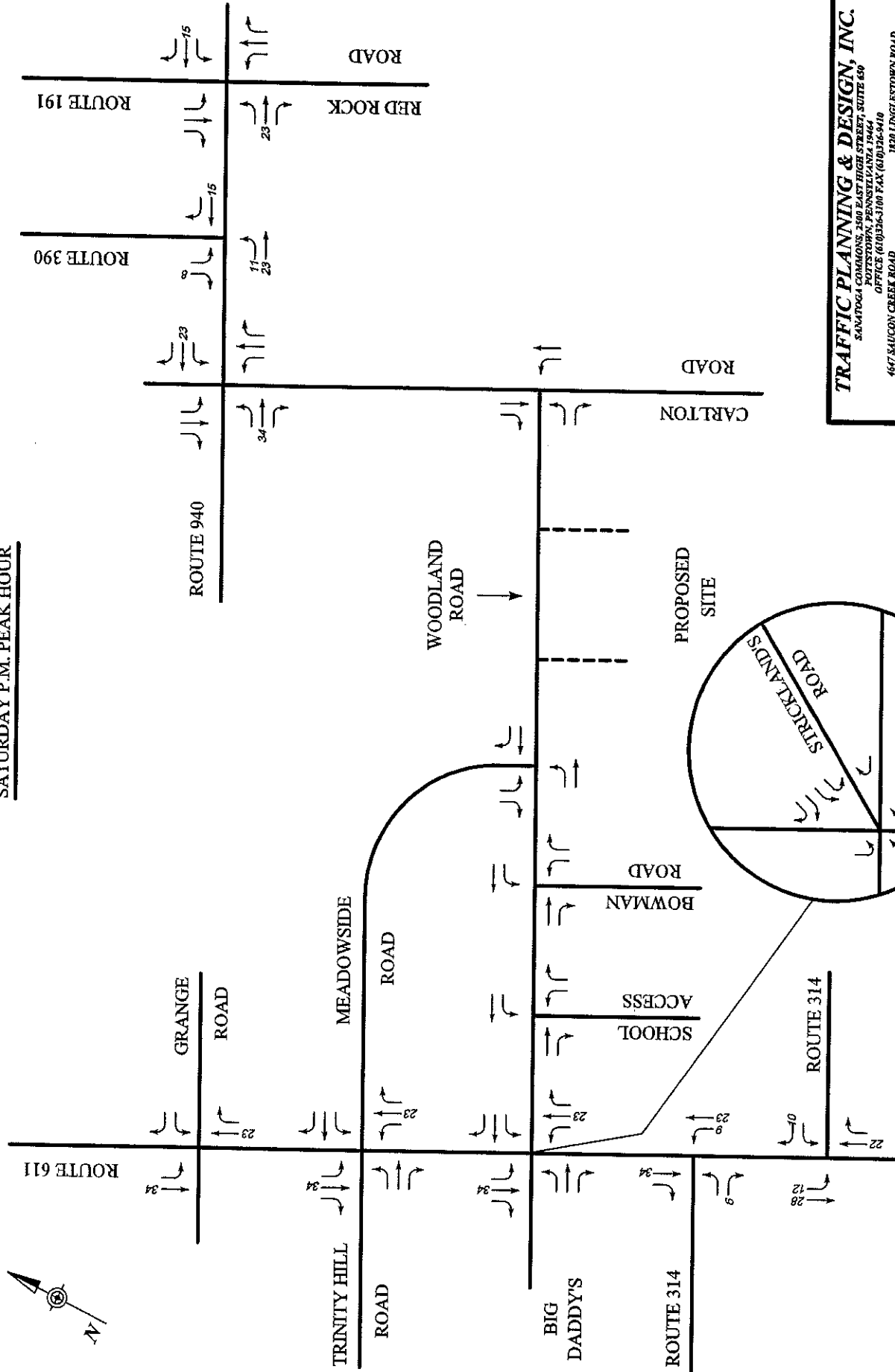

**TRAFFIC PLANNING & DESIGN, INC.**  
 SANATOGA COMMONS, 2500 EAST HIGH STREET, SUITE 450  
 POTTSTOWN, PENNSYLVANIA 19464  
 OFFICE (610)336-3100 FAX (610)336-9410  
 4647 SAUCON CREEK ROAD  
 CENTER VALLEY, PA 18834  
 OFFICE (717)354-1450 OFFICE (717)354-1458 FAX (717)354-4900  
 E-MAIL TRAFFICEXPERTS@TRAFFICPD.COM

FIGURE C-9

LOWE'S  
 SATURDAY P.M. PEAK HOUR

LEGEND:  
 - - - - - = PROPOSED SITE DRIVEWAY  
 SCHEMATIC DRAWING: NOT TO SCALE



FRIDAY P.M. PEAK HOUR

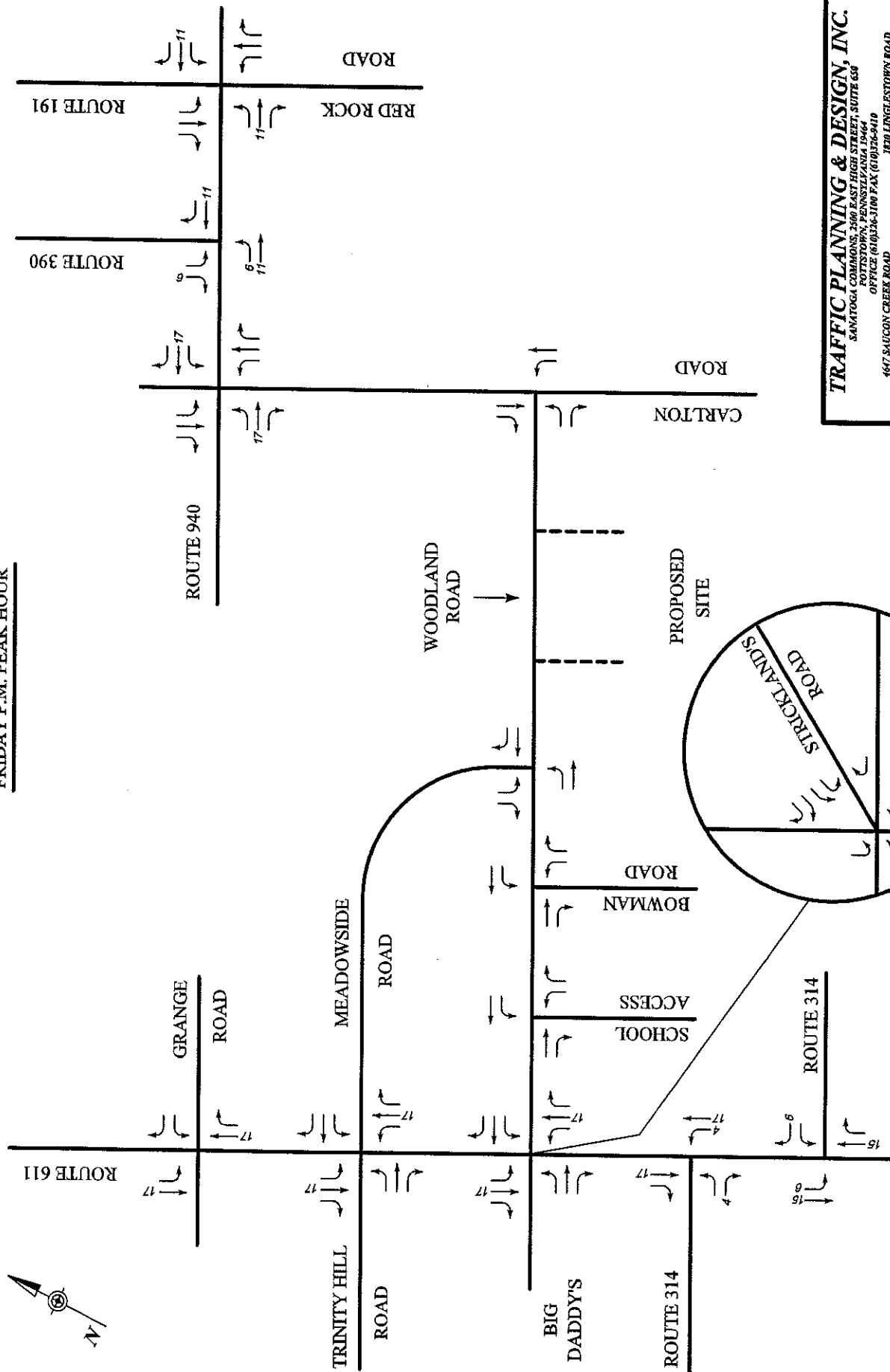

LEGEND:

----- = PROPOSED SITE DRIVEWAY  
SCHEMATIC DRAWING: NOT TO SCALE

**TRAFFIC PLANNING & DESIGN, INC.**  
SAMATOGA COMMONS, 2500 EAST HIGH STREET, SUITE 608  
POTTSTOWN, PENNSYLVANIA 19464  
OFFICE (610)336-3100 FAX (610)326-9419  
4667 SAUCON CREEK ROAD  
CENTER VALLEY, PA 16831  
OFFICE (717)934-4422 FAX (610)933-4236  
1830 LINGLESTOWN ROAD  
HARRISBURG, PA 17110  
OFFICE (717)934-1490 FAX (717)934-4690  
E-MAIL: TRAFFICEXPERTS@TRAFFICPD.COM

FIGURE C-10

HIRSHLAND  
FRIDAY P.M. PEAK HOUR

SATURDAY P.M. PEAK HOUR

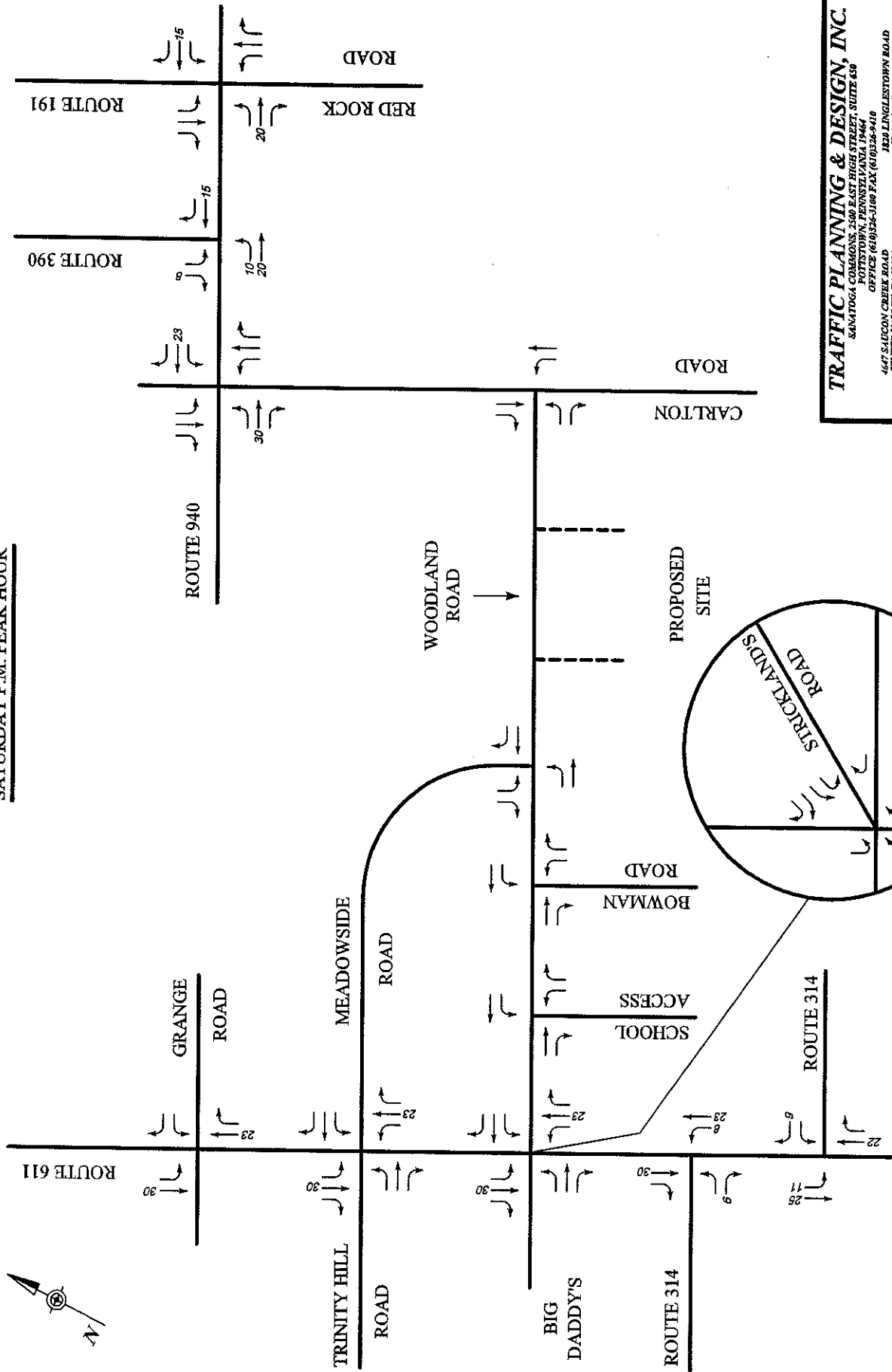

LEGEND:  
 - - - - - = PROPOSED SITE DRIVEWAY  
 SCHEMATIC DRAWING: NOT TO SCALE

**TRAFFIC PLANNING & DESIGN, INC.**  
 8401064 COMMONS, 2500 EAST HIGGS STREET, SUITE 609  
 POTTSTOWN, PENNSYLVANIA 19467  
 OFFICE (610)326-3100 FAX (610)326-9410  
 4647 SALCOON CREEK ROAD  
 CENTER VALLEY, PA 16834  
 OFFICE (717)334-1890 FAX (717)334-4490  
 E-MAIL: TRAFFICPERIS@TRAFFICPD.COM

FIGURE C-11

HIRSHLAND  
 SATURDAY P.M. PEAK HOUR

FRIDAY P.M. PEAK HOUR

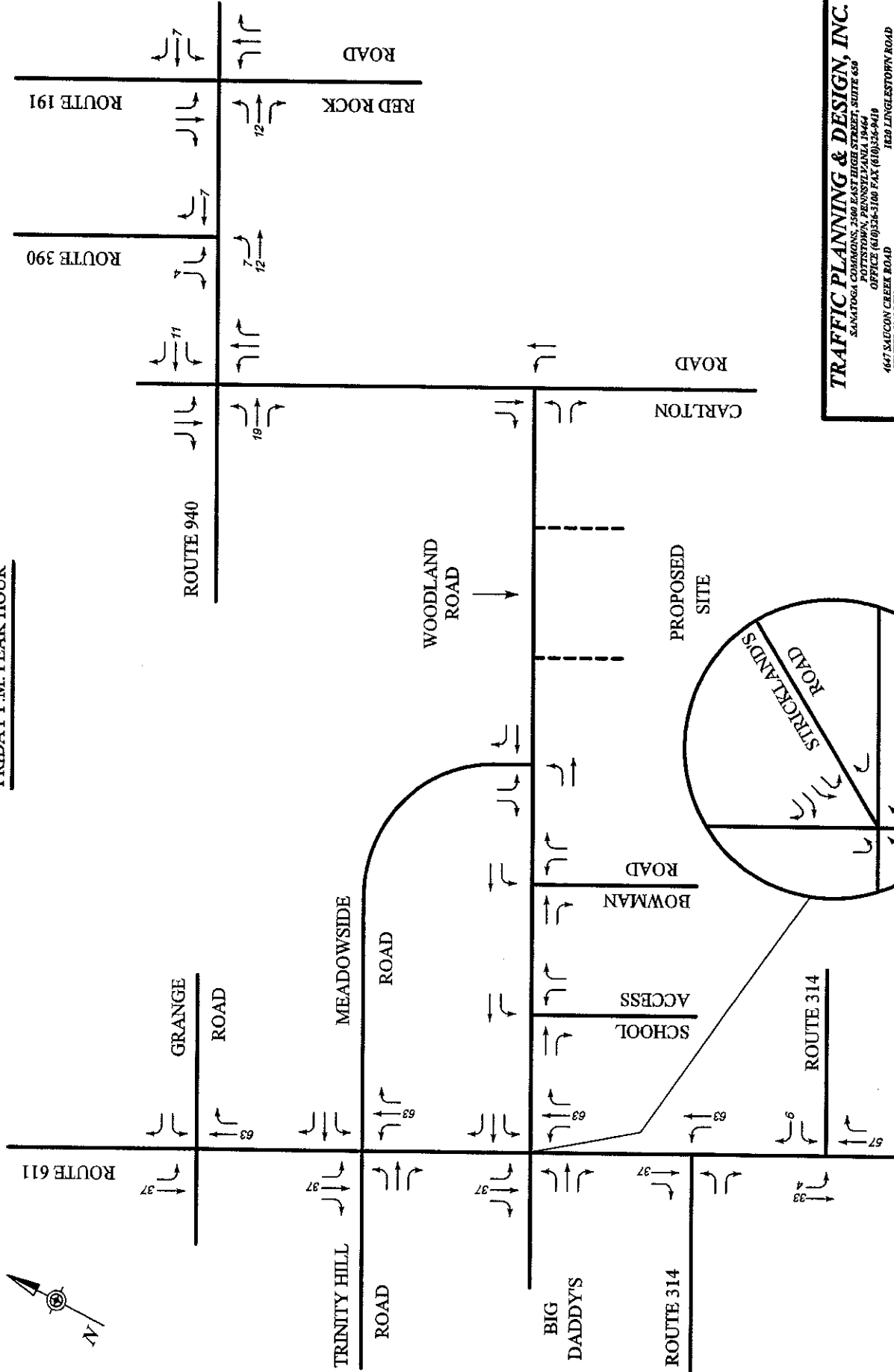

LEGEND:  
 - - - - - = PROPOSED SITE DRIVEWAY  
 SCHEMATIC DRAWING: NOT TO SCALE

**TRAFFIC PLANNING & DESIGN, INC.**  
 SAMITOGA CORAGONS, 2560 EAST HIGH STREET, SUITE 630  
 POTTSTOWN, PENNSYLVANIA 19464  
 OFFICE (610)326-3100 FAX (610)326-9410  
 467 SAUCON CREEK ROAD  
 CENTER VALLEY, PA 1684  
 OFFICE (717)241-1450 FAX (717)241-4499  
 E-MAIL TRAFFICEXPERTS@TRAFICPD.COM

POCONO COUNTY PLACE  
 FRIDAY P.M. PEAK HOUR

FIGURE C-12